

EL-MOASSER

GUIDE

# CONNECT

Plus

By a group of supervisors

Parents' Guide

دليل ولي الأمر

طبعة  
جديدة  
طبقاً لأحدث تعديلات  
كتاب الوزارة ٢٠٢٤

تطبيق  
التعلم التفاعلي



الصف الأول التمهيدي  
رياض الأطفال  
للمدارس الرسمية والخاصة لغات  
الفصل الدراسي الأول

2024

KG1

FIRST TERM

FREE GIFT  
NOT FOR SALE

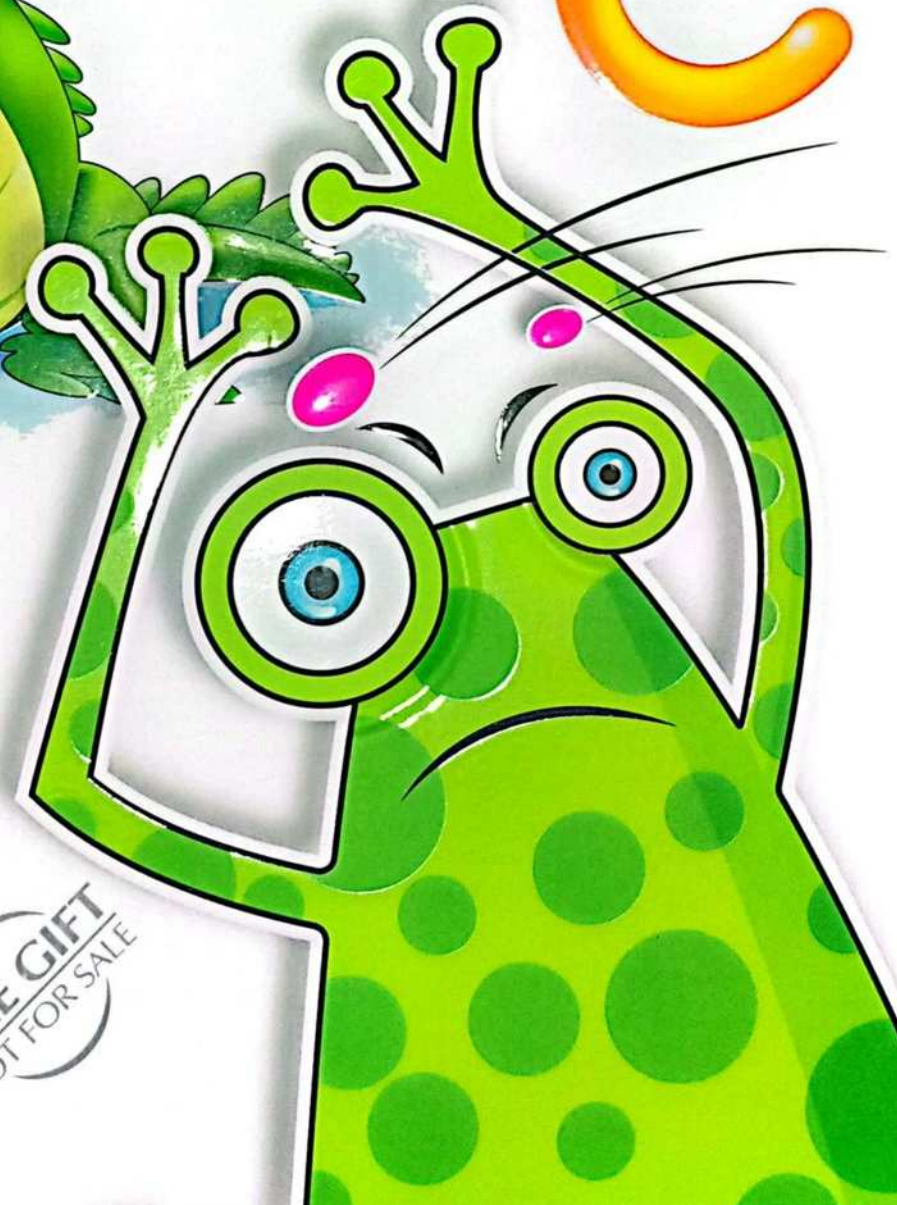

# CONNECT

*Plus*  
By a group of supervisors

Parents' Guide

دليل ولي الأمر

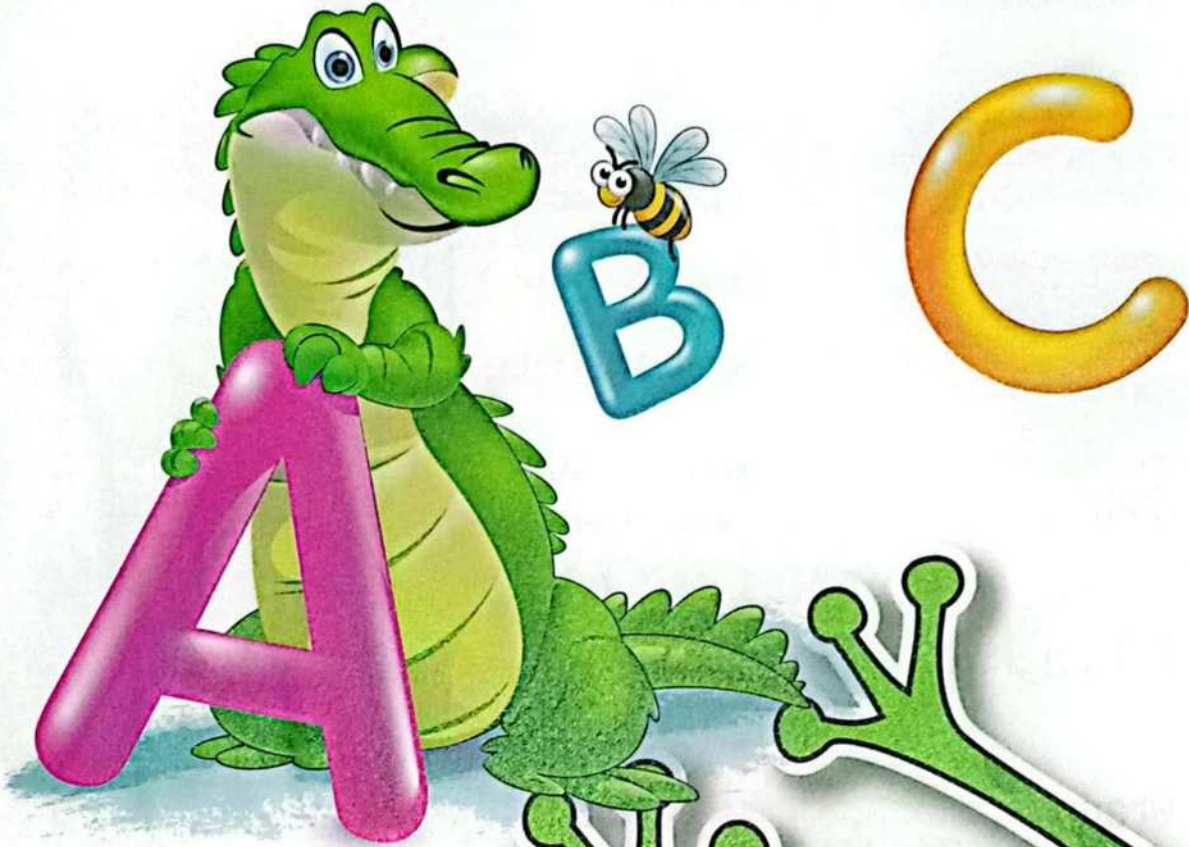

Zahra Online Academy



**AL TALABA BOOKSTORE**

For printing, publication & distribution

El Faggala - Cairo - Egypt

Tel.: 02/ 259 340 12 - 259 377 91

E-mail: info@elmoasserbooks.com

www.elmoasserbooks.com

©15014

**KG1**

**2024**



# إرشادات مهمة

• عزيزي ولى الأمر ساعد طفلك على تعلم الأوضاع الجيدة للكتابة وطرق الإمساك الصحيحة بالقلم.

## ١ أوضاع جيدة للطفل عند الكتابة



١- أن يكون المقعد فى ارتفاع مناسب للطفل.

٢- أن يضع الطفل ذراعيه على مقدمة المقعد عند الكتابة.

## ٢ أوضاع خاطئة للطفل عند الكتابة



## ٣ طرق ذات كفاءة وفاعلية عند الإمساك بالقلم الجاف أو الرصاص

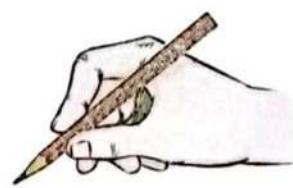
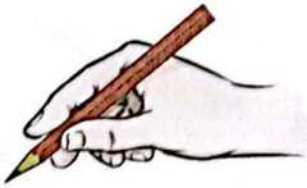

# 1. Pre-Writing Activities



★ هذا الجزء ينمي لدى الطفل مهارة التحكم في القلم أثناء الكتابة والطريقة الصحيحة لحركة اليد.

## Hand Movement

★ Trace the pattern



- ساعد طفلك ان يضع قلمه عند نقطه البدايه ( ● ) و يتتبع النقط مع اتجاه الاسهم.

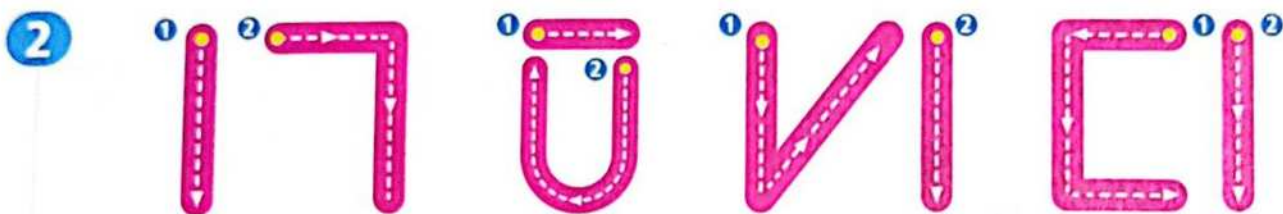

- ساعد طفلك ان يضع قلمه عند نقطه البدايه ( ● ) مرتين في كل نموذج و يتتبع اتجاه الاسهم.

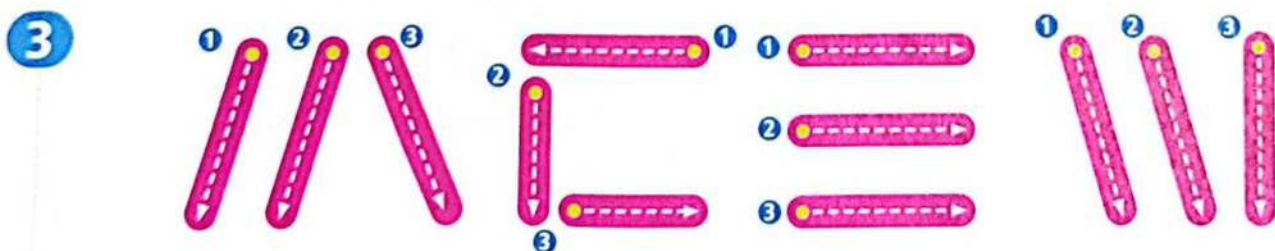

- ساعد طفلك ان يضع قلمه عند نقطه البدايه ( ● ) ثلاث مرات لكل نموذج و يتتبع اتجاه الاسهم.

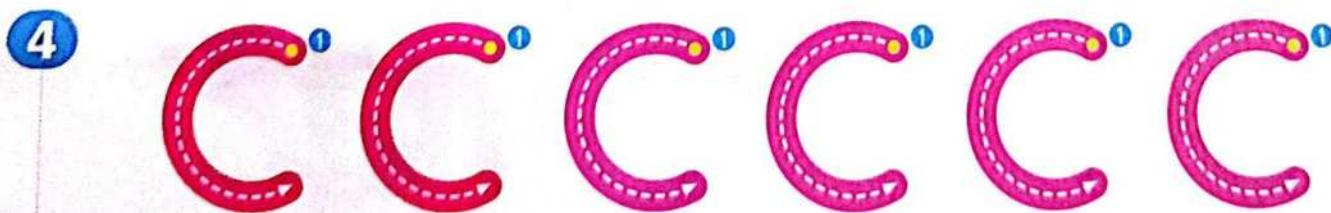

- ساعد طفلك ان يضع قلمه عند نقطه البدايه ( ● ) و يتتبع اتجاه الاسهم لرسم النماذج الدائرية.

5

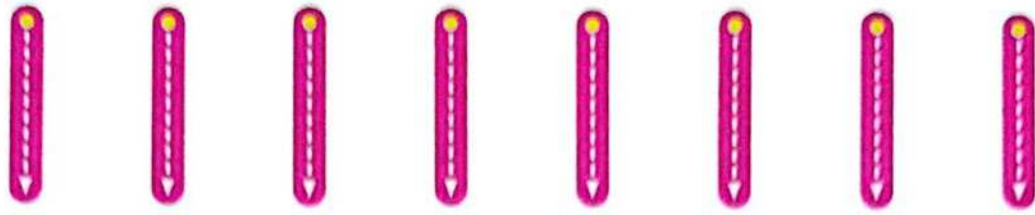

- ساعد طفلك ان يضع قلمه عند نقطه البدايه ( ● ) و يتتبع اتجاه الاسهم لرسم النماذج المستقيمة.

6

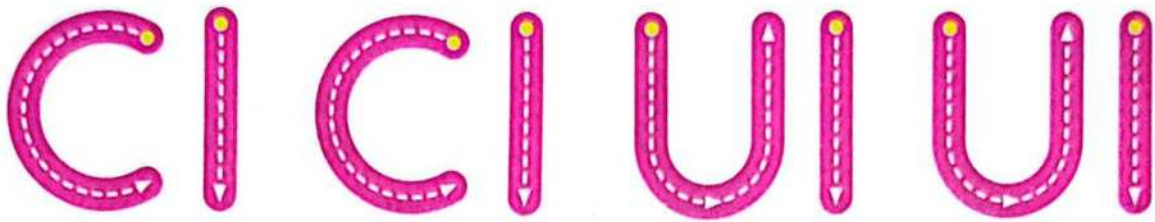

- ساعد طفلك ان يضع قلمه عند نقطه البدايه ( ● ) و يتتبع اتجاه الاسهم لرسم النماذج الدائرية والمستقيمة.

7

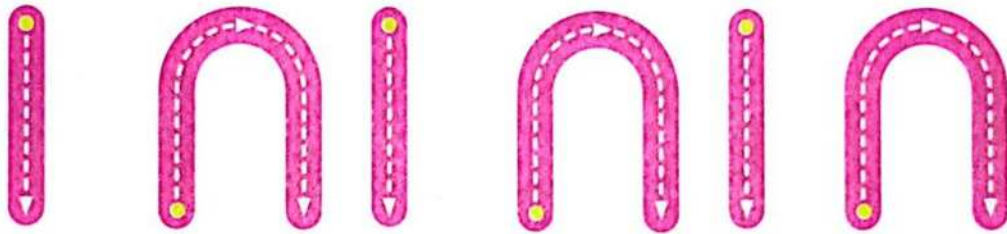

- ساعد طفلك ان يضع قلمه عند نقطه البدايه ( ● ) و يتتبع اتجاه الاسهم لرسم النماذج المستقيمة والدائرية.

8



- ساعد طفلك ان يضع قلمه عند نقطه البدايه ( ● ) و يتتبع اتجاه الاسهم لرسم النماذج.

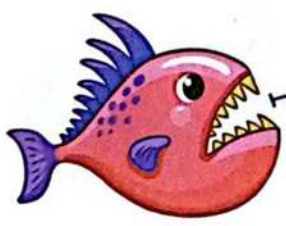
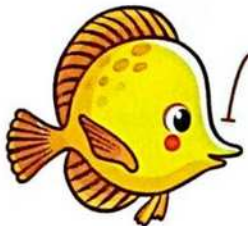

## 2. Writing guidelines



• السطور الأربعة المستخدمة في هذا الكتاب تساعد على ضبط حجم وشكل الحرف وتحسين الخط.

 **Plane line** خط (الطائرة)

 **Sky line** خط (السماء)  
هو الخط الأعلى وبعض الحروف تكون صاعدة لهذا الخط.

**English**

**Grass line** خط (الحشائش)  
تكتب معظم الحروف بين خطي الطائرة والحشائش.

**Worm line** خط (الدودة)  
هو الخط الأسفل وبعض الحروف تكون هابطة لهذا الخط.



### Capital letters shapes :

• تكتب الحروف الكبيرة (Capital letters) بين خط السماء وخط الحشائش.



### Small letters shapes :

• تكتب الحروف الصغيرة (Small letters) بين خط الطائرة وخط الحشائش.

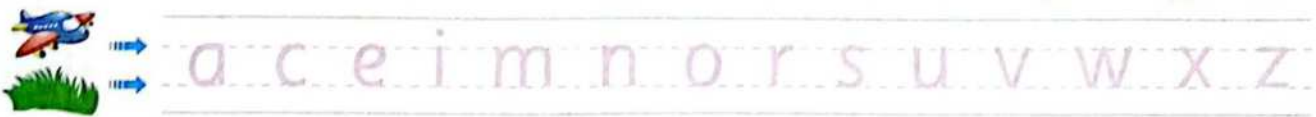

• بعض الحروف الصغيرة (Small letters) تكون صاعدة لأعلى (بين خطي السماء والحشائش).

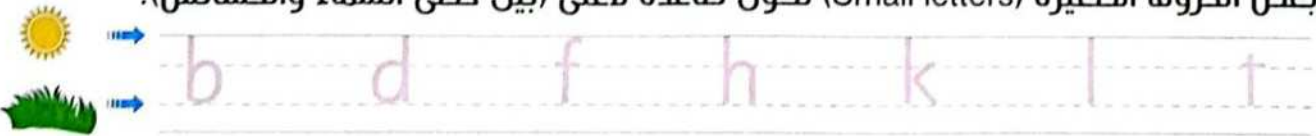

• بعض الحروف الصغيرة (Small letters) تكون هابطة لأسفل (بين خطي الطائرة والدودة).



• Help your child to know the right way of writing capital and small letters.

# 3. The Alphabet

٢. حروف الهجاء



★ Look and trace.

Aa

Bb

Cc

Aa

Bb

Cc

Aa

Bb

Cc

Dd

Ee

Ff

Dd

Ee

Ff

Dd

Ee

Ff

• Ask your child to look at the written letters and trace the dotted ones according to the arrows.

اطلب من طفلك أن ينظر إلى الحروف المكتوبة ويتتبع النقط طبقاً لاتجاهات الأسهم.



Gg

Hh

Ii

Gg

Hh

Ii

Gg

Hh

Ii

Jj

Kk

Ll

Jj

Kk

Ll

Jj

Kk

Ll

M m

N n

O o

M m

N n

O o

M m

N n

O o

P p

Q q

R r

P p

Q q

R r

P p

Q q

R r

M m

N n

O o

M m

N n

O o

M m

N n

O o

P p

Q q

R r

P p

Q q

R r

P p

Q q

R r

Ss

Tt

Uu

Vv

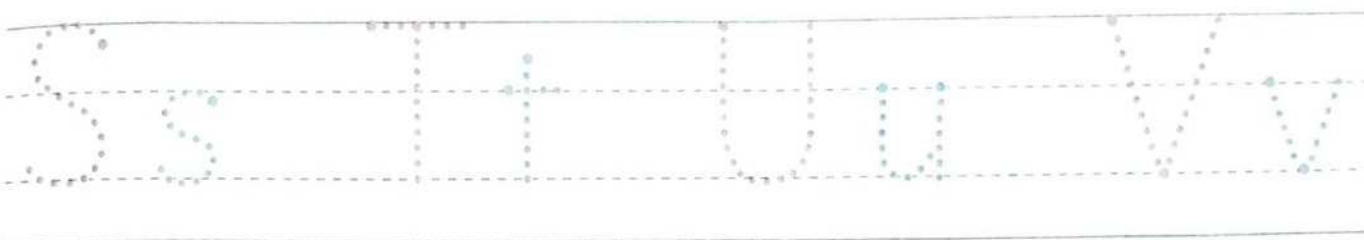
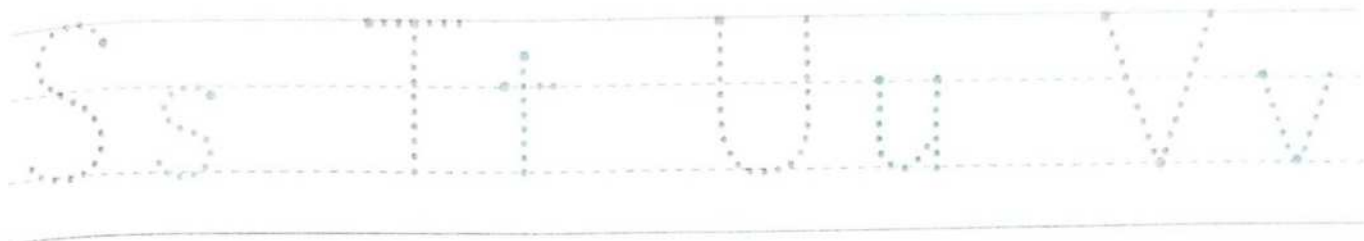

Ww

Xx

Yy

Zz

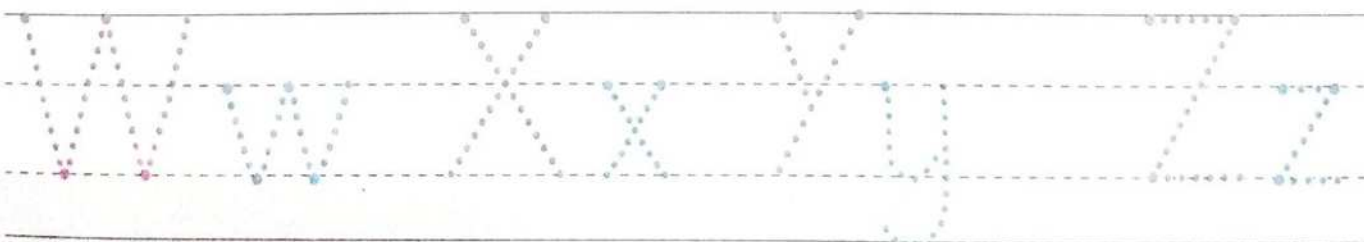
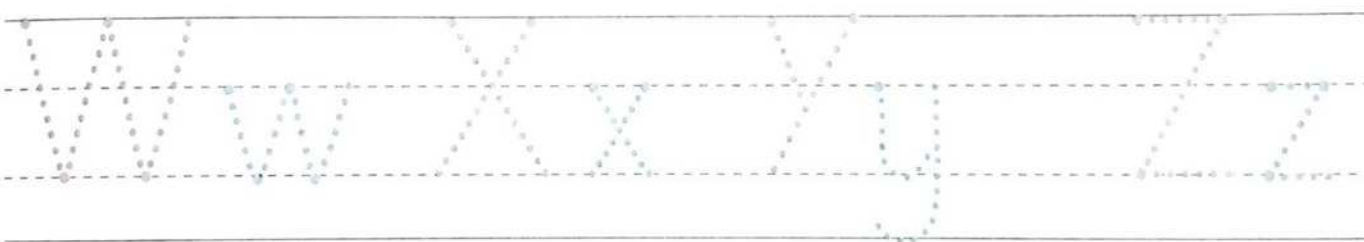

## 4. How to improve your

## handwriting

الأنشطة تساعدك على تحسين الخط



### ★ Look and write.

- Median letters.

• بعض الحروف التي تكتب في الوسط (بين السطرين).

a c e i m n o r s u v w x z

- Ascenders letters.

• بعض الحروف التي تكتب لأعلى.

b d f h k l t

- Descenders letters.

• بعض الحروف التي تكتب لأسفل.

g j p q y

- Capital letters are always upper. • الحروف الكبيرة (Capital letters) تكون دائماً لأعلى.

A B C D E F G H

• Ask your child to look at the written letters and write them again.

اطلب من طفلك ان ينظر إلى الحروف المكتوبة ويكتبها مرة اخرى.

# 5. Alphabet Activities



★ **Activity 1** ★ Look, point and say.

<b>A</b> a	<b>B</b> b	<b>C</b> c	<b>D</b> d	<b>E</b> e		
<b>F</b> f	<b>G</b> g	<b>H</b> h	<b>I</b> i	<b>J</b> j	<b>K</b> k	<b>L</b> l
<b>M</b> m	<b>N</b> n	<b>O</b> o	<b>P</b> p	<b>Q</b> q	<b>R</b> r	<b>S</b> s
<b>T</b> t	<b>U</b> u	<b>V</b> v	<b>W</b> w	<b>X</b> x	<b>Y</b> y	<b>Z</b> z

علم طفلك أن لكل حرف شكلين

**Capital** حرف كبير

**Small** حرف صغير



• ساعد طفلك أن ينظر إلى الحروف ويشير إليها ويقولها (كرر النشاط أكثر من مرة).

★ **Activity 2** ★ Listen, point and repeat.

<b>B</b> b	<b>P</b> p	<b>F</b> f	<b>V</b> v	<b>K</b> k	<b>Q</b> q
<b>C</b> c	<b>S</b> s	<b>G</b> g	<b>J</b> j	<b>D</b> d	<b>T</b> t



علم طفلك أن هناك حروف متشابهة في النطق.

• ساعد طفلك أن يستمع إلى كل حرفين معاً ويلاحظ التشابه في النطق بينهم ويردد.

★ Activity 3 ★ Choose the next letter.

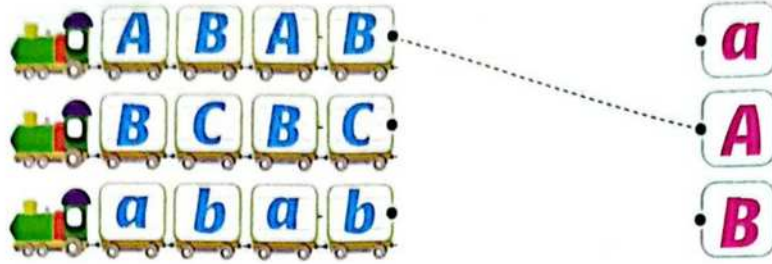

أطلب من طفلك أن ينظر إلى الحروف ويقوم بتوصيلها بالحرف التالي له.

★ Activity 4 ★ Color the same letter.

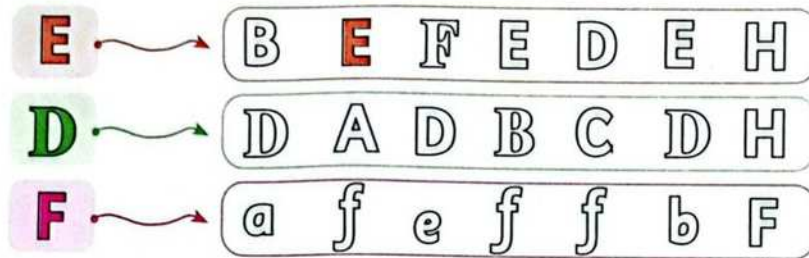

أطلب من طفلك أن يلون المربع الموجود فيه نفس الحرف المعطى له.

★ Activity 5 ★ Look and put [✓] or [X].

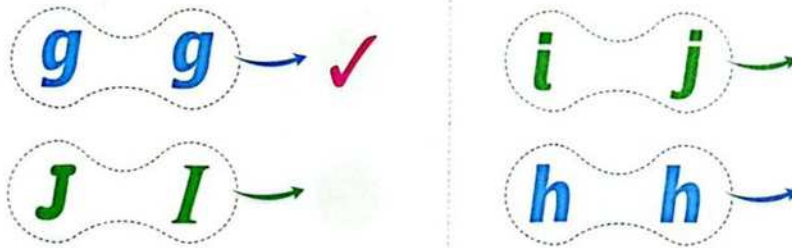

أطلب من طفلك أن ينظر إلى كل حرفين ويضع (✓) إذا كان الحرفين متشابهين و (X) إذا كان الحرفين غير متشابهين.

★ Activity 6 ★ Circle the same letter.

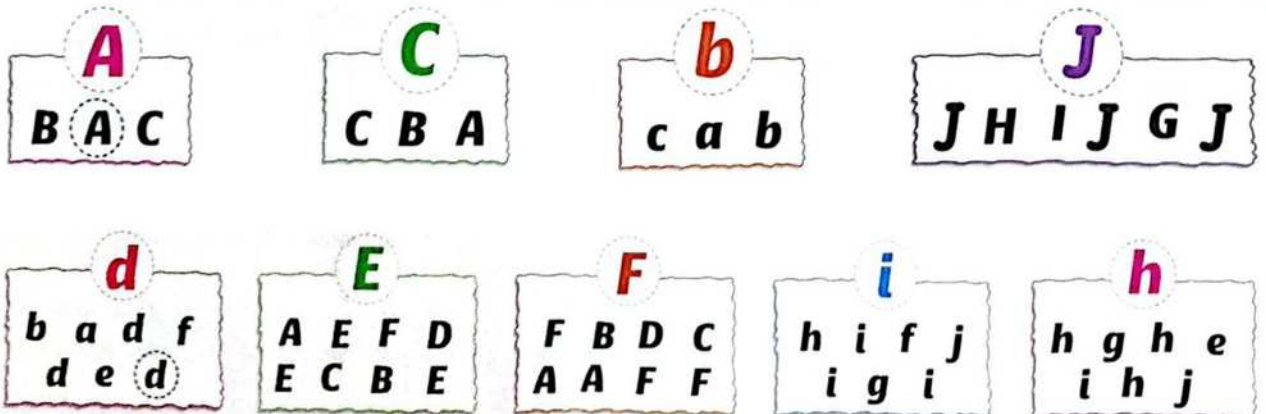

أطلب من طفلك أن ينظر إلى الحرف ويضع دائرة حول المشابه له.

★ **Activity 7** ★ Match the same letter.

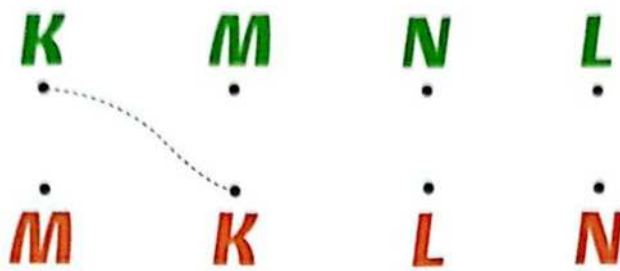

أطلب من طفلك أن يقوم بتوصيل كل حرف بالحرف المشابه له.

★ **Activity 8** ★ Circle the letter in the words.

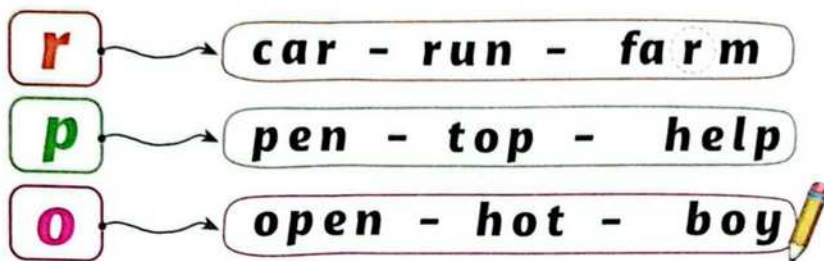

أطلب من طفلك أن يضع دائرة حول الحرف المشابه للحرف المعطى له.

★ **Activity 9** ★ Look and Color.

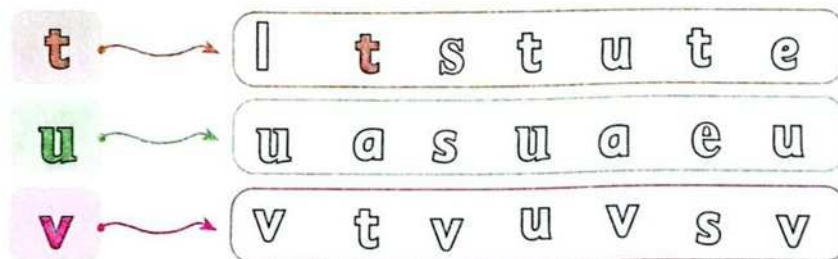

أطلب من طفلك أن يلون المربع الموجود فيه نفس الحرف المعطى له.

★ **Activity 10** ★ Find W X Y Z and circle.

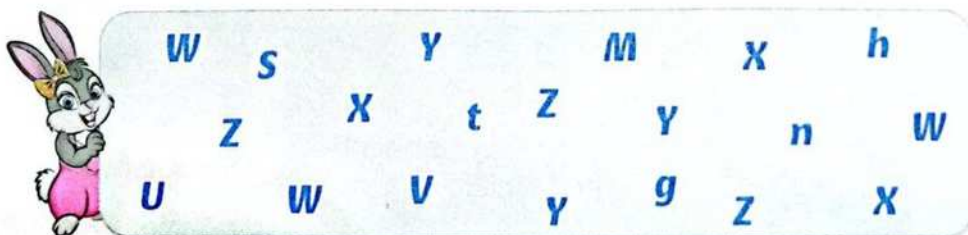

أطلب من طفلك أن يجد الحروف W X Y Z ويضع دائرة حولهم.



# Contents

## Part 1

### Theme 1

#### Who am I ?

Unit 1	This is me !	24
Unit 2	In my classroom	59

### Theme 2

#### The world around me

Unit 3	Our animals	103
Unit 4	Our world	142
Story	The Boys and the Frogs	187

## Part 2

General Revision on units	198
---------------------------	-----



1

# THEME

Who am I?

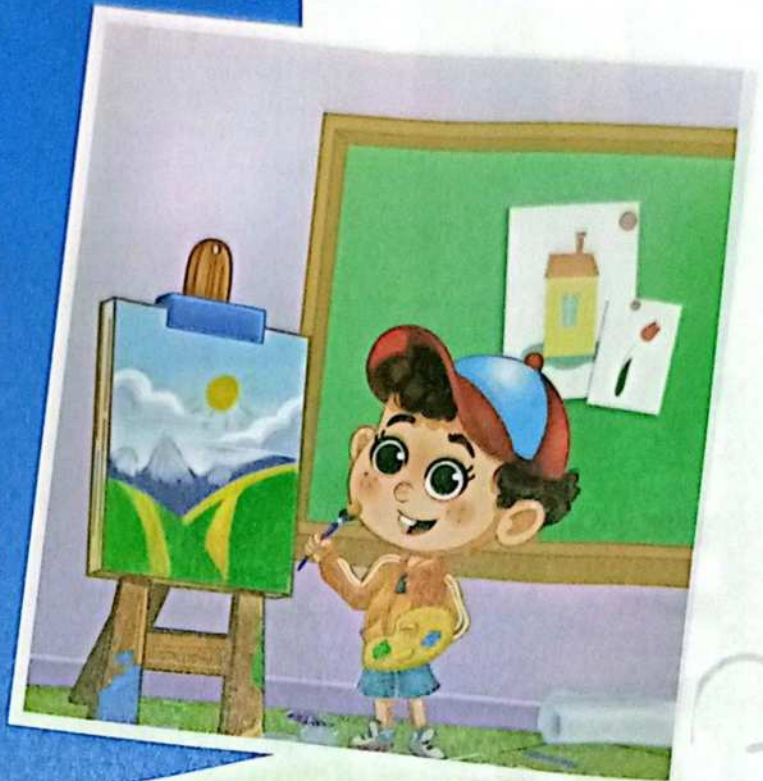

# Unit 1 Objectives

By the end of the unit, your child will be able...

بنهاية هذه الوحدة، سيكون طفلك قادر على ...

## Lessons 1 & 2

• Objectives : To identify basic family members

• ان يتعرف على اعضاء الأسرة الأساسيين

• Vocabulary : Adam, Dina, daddy, mommy, brother, sister

- آدم، دينا، أب، أم، أخ، أخت

## Lessons 3 & 4

• Objectives : To talk about family

• ان يتحدث عن العائلة

## Lesson 5

• Objectives : 1. To be able to distinguish between 1 and 2 in numerals and concept

1- ان يكون قادرًا على التمييز بين رقم 1 ورقم 2 بين الأعداد

2. To talk about facial features (two ears, one mouth)

2- ان يتحدث عن ملامح الوجه (أذنين، فم)

• Vocabulary : eyes, ears, mouth, nose, hair

- عيون، اذان، فم، أنف، شعر

• Language : I have two ears, I have one mouth.

- انا لى اذان، ولدى فم.

## Lessons 6 & 7

• Objectives : 1. To identify parts of the body

1- ان يتعرف على أجزاء الجسم

2. To sing a song and do actions

2- ان يغنى أغنية ويقوم بأفعال

3. To talk about eye color

3- ان يتحدث عن لون العين

• Vocabulary : arm, foot, hand, leg, brown, blue, green

- ذراع، قدم، يد، ساق، لون بنى، أزرق، أخضر

• Language : Touch your arm, touch your leg.

- المس ذراعك، المس ساقك.

## Lesson 8

• Objectives : 1. To link body parts with the senses

1- ان يربط بين أجزاء الجسم والحواس

2. To be able to differentiate between them

2- ان يكون قادرًا على التمييز بينهم

• Vocabulary : nose, hand, mouth, ears, eyes, see, smell, hear

- أنف، يد، فم، اذان، عيون، يرى، يشم، يسمع

• Language : I smell with my nose.

- انا اشم بأنفى.

## Lessons 9 & 10

• Objectives : To be able to say and find B/b and H/h orally and in writing

- ان يكون قادرًا على قول وإيجاد حرف (Bb), (Hh) نطقًا وكتابة

• Vocabulary : Busy Bee, bye, blue, brown, hello, hair, hand, Hana

- النحلة النشيطة، إلى اللقاء، أزرق، بنى، أهلاً، شعر، يد، هنا

## Lessons 11 & 12

• Objectives : To identify and match colors to objects of the same color

- ان يتعرف على الألوان و يصلها مع الأشياء من نفس اللون

• Vocabulary : • red, blue, yellow, green, orange, brown, It's ....

- احمر، أزرق، أصفر، أخضر، برتقالى، بنى، إنه ...

• I like ...

- انا احب ...

## Lesson 13

• Objectives : To listen and follow a picture story

- ان يستمع ويتتبع قصة مصورة



**Vocabulary**

★ Listen and repeat. **استمع وردد.**

mommy أم

daddy أب



sister أخت

brother أخ



**Activity**

★ Trace, match and Color. **تتبع، صل ولون.**

1.



2.



3.



daddy

brother

sister

★ Listen and look. استمع وانظر.



Hello! I'm Busy Bee.  
This is my family. Buzzzzz.  
أهلاً! أنا النحلة النشيطة. هذه عائلتي.

Hello! My name  
is Dina. This is  
my mommy. This  
is my brother,  
Adam.

أهلاً اسمي دينا. هذه  
أمي. هذا أخي آدم.

My name is  
Adam. This is  
my daddy. This  
is my sister,  
Dina.

اسمي آدم. هذا أبي.  
هذه أختي دينا.



• Help your child listen to the dialogue and look at the picture.

- ساعد طفلك في الاستماع إلى المحادثة ثم انظر إلى الصورة.

# Language

## 1 Introducing yourself : تقديم نفسك :

I'm ..... انا اكون....



I'm Adam.



I'm Dina.

## 2 Introducing my family.

تقديم عائلتي :

This is my ..... هذا يكون....



This is my daddy.



This is my mommy.



## Activity ★ Look and circle. انظر وضع دائرة.

1.  This is my [ mommy - daddy ].
2.  This is my [ daddy - brother ].
3.  This is my [ mommy - sister ].
4.  This is my [ daddy - sister ].

# Writing corner



★ Listen, trace and write. استمع، تتبع واكتب.

mommy



mommy

daddy



daddy

brother



brother

sister



sister

family



family

Hello



Hello

• Help your child to listen, trace the dotted words, then write it.

– ساعد طفلك ان يستمع ، يتتبع الكلمات المكتوبة على شكل نقاط ثم يكتبها .

# Activities on lessons 1 & 2



1 Listen and circle. استمع وضع دائرة.

1. daddy



2. brother



2 Listen and match. استمع وصل.

Adam

sister

daddy



3 Listen and tick [✓]. استمع وضع علامة (✓).

1.



mommy

daddy

2.



Dina

Adam

4 Read and write. اقرأ واكتب.

1.



This is my \_\_\_\_\_.

2.



This is my \_\_\_\_\_.



**5 Trace and circle.** . تتبع وضع دائرة .

1.



mommy

2.



brother

**6 Look and circle (✓) or (X).** . انظر وضع دائرة حول علامة (✓) او (X) .

1.



sister

✓ / X

2.



mommy

✓ / X

3.



daddy

✓ / X

**7 Unscramble and write.** . اعد ترتيب الحروف واكتب .

1.



r b o t h e r

\_\_\_\_\_

-----

\_\_\_\_\_

2.



m m o m y

\_\_\_\_\_

-----

\_\_\_\_\_

**8 Copy the following.** . انسخ الآتي .

• She is my mommy.

\_\_\_\_\_

-----

\_\_\_\_\_



Vocabulary

★ Listen and repeat. استمع وردد.

eye عين

mouth فم

nose انف

ear اذن

hair شعر

**Parts of the body**  
أجزاء الجسم



Activity

★ Color and number.

لوّن ورقّم.

1. hair

2. mouth

3. eye

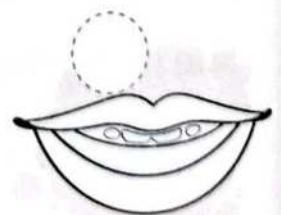

# Language

We use **[This]** when we talk about a singular noun.

This is + **إسم مفرد** .....



This is my mommy.  
هذه أمي.

This is my nose.  
هذه أنفي.

**Activity** ☆ Stick, color and write. الصق ، لون واكتب.

Draw or stick your photo

Draw or stick one of your family members

I'm .....

This is my .....

- Help your child to identify and express something / someone close to him / her using the demonstrative pronoun (This...).
- Help your child stick his / her photo and one of his / her family members, color the frame and write his/her name.



★ Listen, trace and write. استمع، تتبع واكتب.

eye



eye

nose

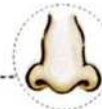

nose

hair



hair

mouth



mouth

ear



ear

body



body

## Notes for parents

- Help your child to listen, trace the dotted words, then write it.

ساعد طفلك أن يستمع ، يتتبع الكلمات المكتوبة على شكل نقاط ثم يكتبها .

# Activities on lessons 3 & 4



1 Which one is similar? Circle and Color. اى منهم متشابهة ؟ ضع دائرة ولون.

1. This is my daddy.



2. This is my brother.



2 Listen and circle. استمع وضع دائرة.

1. nose

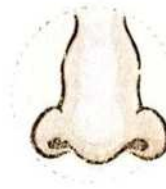

2. ear

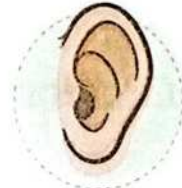

3 Listen and match. استمع وصل.

eye

mouth

ear



4 Listen and tick [✓]. استمع وضع علامة (✓).

1.  eye   
nose

2.  ear   
mouth

5 Listen and circle. استمع وضع دائرة.

1.  It's my. mouth ..  
ear

2.  This is my. brother  
mommy

3.  This is my. hair ..  
mouth

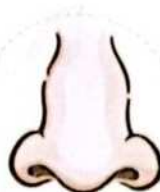
4.  This is my. hair ..  
nose

6 Trace. تتبع.

Hello! I'm Adam.

7 Circle and write. ضع دائرة واكتب.

1.  i  
a  
e  
\_ye

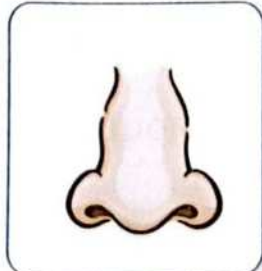
2.  n  
m  
p  
\_ose

3.  m  
h  
l  
\_air

## Language

## 1 have

للتعبير عن ملكيتي لشيء ما :

I

have

one nose.

I **have** two arms.  
أنا أمتلك ذراعين.I **have** one mouth.  
أنا أمتلك فم واحد.

## 2 Plural

صيغة الجمع :

ear

leg



eye

eyeS

earS

legS



★ Most singular change into plural by adding "s".

معظم الأسماء المفردة تتحول إلى الجمع بإضافة حرف "s".

Singular المفرد

Plural الجمع



one ear

two earS



one arm

two armS



# Activities on lesson 5



1 Look and circle. انظر وضع دائرة.

1. I have two  $\frac{\text{eye}}{\text{eyes}}$ .

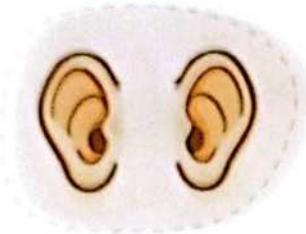

2. I have two  $\frac{\text{ears}}{\text{ear}}$ .

3. I have  $\frac{\text{one}}{\text{two}}$  nose.



4. I have two  $\frac{\text{hand}}{\text{hands}}$ .

2 Count and circle. عد وضع دائرة.

1.

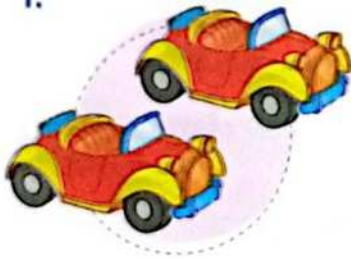

1 2

2.



1 2

3.

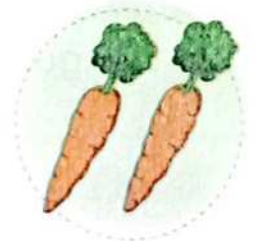

1 2

3 Copy the following. انسخ الآتي.

• I have one mouth.

\_\_\_\_\_

\_\_\_\_\_

\_\_\_\_\_





Vocabulary

★ Listen and repeat. استمع وردد.

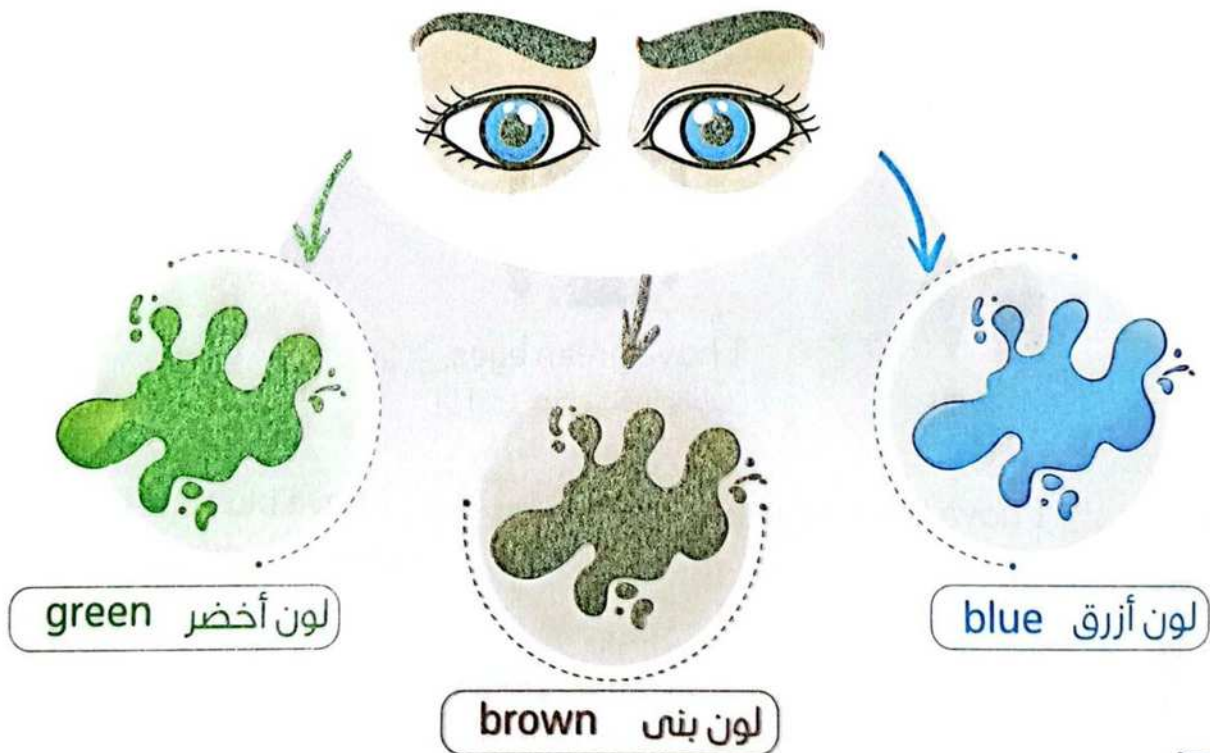

# Sing and do



Touch your arm.  
المس ذراعك.

Arm, arm, touch your arm.  
Leg, leg, touch your leg.  
Touch your arm,  
Touch your leg!  
Touch your arm,  
Touch your leg!



Touch your leg.  
المس ساقك.



Touch your foot.  
المس قدمك.

Hand, hand, touch your hand.  
Foot, foot, touch your foot.  
Touch your hand,  
Touch your foot!  
Touch your hand,  
Touch your foot!

We are all beautiful.  
نحن جميعاً رائعون.



I have green eyes.  
انا لدي عيون خضراء اللون.



I have blue eyes.  
انا لدي عيون زرقاء اللون.



I have brown eyes.  
انا لدي عيون بنية اللون.



## Notes for parents

- Sing with your child and let him / her do the instructions.

غن مع طفلك و دعه/ دعتها تنفذ التعليمات.

touch يلمس



★ Listen, trace and write. استمع، تتبع واكتب.

arm



arm

hand



hand

foot



foot

leg



leg

touch



touch

blue



blue

• Help your child to listen, trace the dotted words, then write it.

- ساعد طفلك أن يستمع ، يتتبع الكلمات المكتوبة على شكل نقاط ثم يكتبها .

# Activities on lessons 6 & 7



1 Listen and circle. استمع وضع دائرة.

1. arm

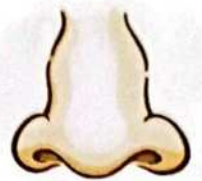

2. leg



3. foot

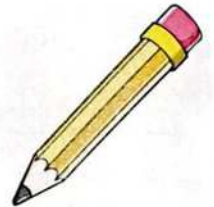

2 Listen and match. استمع وصل.

hand

foot

arm



3 Listen and tick (✓). استمع وضع علامة (✓).

1.



arm

leg

2.



hair

hand

**4 Listen and circle.** استمع وضع دائرة.

1. I have green eyes.



2. I have brown eyes.



**5 Trace and Color.** تتبع ولون.

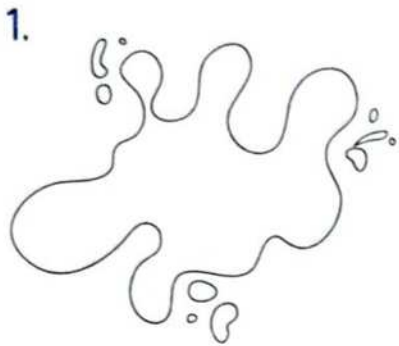

blue

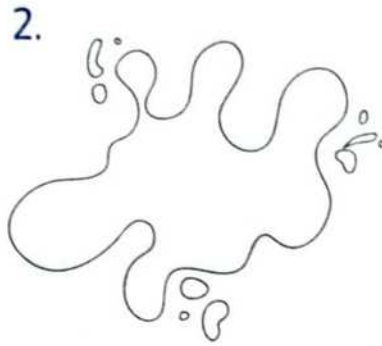

green

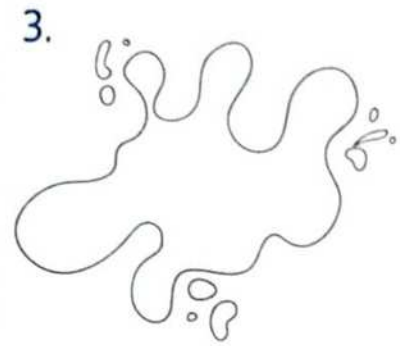

brown

**6 Listen and circle.** استمع وضع دائرة.

1.



green eyes  
red

2.



blue eyes  
ears

3.



red eyes  
brown

4.



one eyes  
eye

★ Listen and repeat. استمع وردد.

### smell



I smell with my nose.

أنا أشم بأففى.

### touch



I touch with my hand.

أنا ألمس بىدى.

### hear

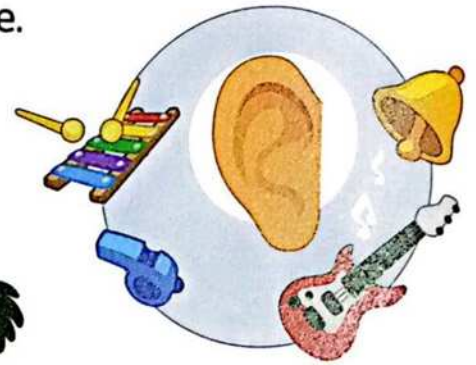

I hear with my ears.

أنا أسمع بأذنانى.

### see



I see with my eyes.

أنا أرى بعينائى.

### taste



I taste with my mouth.

أنا أتذوق بفمى.



#### Notes for parents

- Help your child identify his / her five senses.

ساعد طفلك أن يتعرف على حواسه الخمس.

★ Activity ★ Trace and match. تتبع وصل.



see



hear



touch

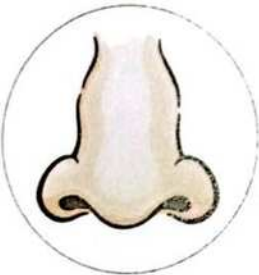

smell



taste



• Help your child trace the words and match each sense with the suitable picture.

- ساعد طفلك أن يتتبع الكلمات ويوصل كل حاسة بالصورة المناسبة لها.



Vocabulary

★ Listen and repeat. استمع وردد.

حقيبة bag



النحلة النشيطة Busy Bee



لون بني brown



الى اللقاء! Bye!

B b



لون أزرق blue



يد hand

H h



أهلاً! Hello!



هنا Hana



شعر hair

Notes for parents

• Help your child listen to the words that have the /b/ and /h/ sounds and repeat them.

ساعد طفلك أن يستمع إلى الكلمات التي تحتوي على الصوتين /b/ و /h/ ويرددها.



★ Listen and trace. استمع وتتبع.

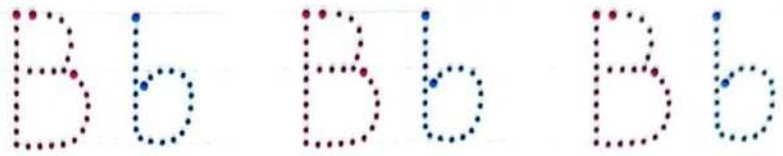

Bye!

bag

brown

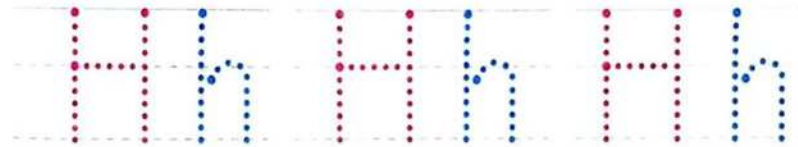
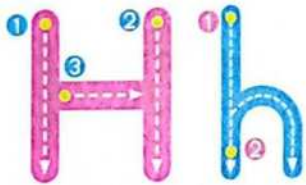

Hello!

hair

hand

• Help your child listen to the words that have the /b/ and /h/ sounds and trace the letter and dotted words.  
 - ساعد طفلك ان يستمع إلى الكلمات التي تبدأ بالصوتين /b/ ، /h/ ويتتبع الحروف والكلمات المكتوبة على شكل نقاط.

# Activities on lessons 9 & 10



1 Listen and circle. استمع وضع دائرة.

1. bag



2. hand



3. Bye!



2 Listen and match. استمع وصل.

Busy Bee

hair

hand



3 Listen and tick [✓]. استمع وضع علامة (✓).

1.



ear

hand

2.



Hello!

hair

4 Circle and write. ضع دائرة واكتب.

1.

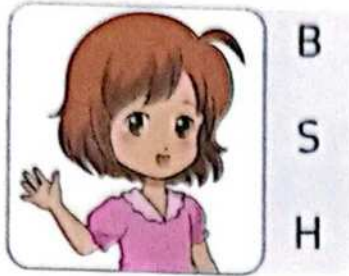

B  
S  
H

- ello!

2.



T  
S  
B

Busy - ee

5 Trace and Color. تتبع ولون.

1.



Busy Bee

2.



hair

3.

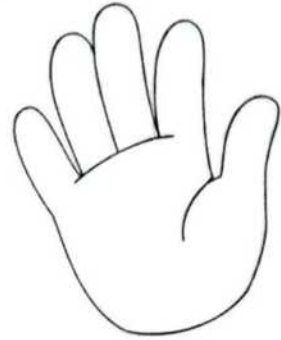

hand

6 Trace and circle the pictures with [Hh].

تتبع وضع دائرة حول الصور التي تبدأ بحرف (Hh).

Hh



Bb



## Colors ألوان



brown

بنى



orange

برتقالى



blue

ازرق



yellow

اصفر



red

احمر



green

اخضر



### A new Color

★ Primary colors are : الألوان الأساسية هي:



Red



Blue



Yellow

★ Mixing primary colors gives new colors :

ند خلط الألوان الأساسية نحصل على ألوان جديدة

Red + Yellow  
= Orange



Red and yellow  
make orange.

Blue + Yellow  
= Green



Blue and yellow  
make green.

Yellow + Red + Blue  
= Brown



Yellow, red and blue  
make brown.

# Language

1 We use [like] to express what we love.

تستخدم (like) للتعبير عما نحب.



I like orange.  
أحب اللون البرتقالي.



I like red.  
أحب اللون الأحمر.

2 What color is it?

ما لونه / لونها؟

It's لون.



What color is it?  
ما لونها؟



It's yellow.  
لونها أصفر.



## Activity ☆ Trace and Color. تتبع ولون.

1.



red

2.

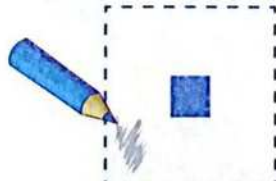

blue

3.

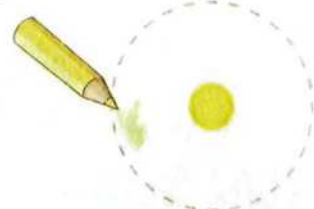

yellow

1. Help your child to express what he/she loves.

2. Help your child learn how to ask and answer about colors.

• Help your child trace the words and color the shapes according to the given colors.

- ساعد طفلك أن يعبر عما يحب.

- ساعد طفلك أن يتعلم كيف يسأل ويجيب عن الألوان.

- ساعد طفلك أن يتتبع الكلمات ويلون الأشكال طبقاً للألوان المعطاة له.

# Activities on lessons 11 & 12



1 Listen and circle. استمع وضع دائرة.

1. green



2. red



2 Listen and circle. استمع وضع دائرة.

1.



Red and yellow make  $\frac{\text{orange}}{\text{blue}}$ .

2.



Blue and yellow make  $\frac{\text{blue}}{\text{green}}$ .

3 Listen and match. استمع وصل.

orange

red

blue



4 Listen and tick [✓]. استمع وضع علامة (✓).

1.



blue

yellow

2.



orange

red

A new color

لون جديد

We can mix colors !

نستطيع أن نخلط الألوان !



★ Listen and look. استمع وانظر.



### Notes for parents

Unit 1

- Help your child listen to the scenes of the story and look at the pictures.

- طفلك في الاستماع إلى مشاهد القصة ثم النظر إلى الصور.



What color is the paint ?

مالون الدهان؟

Oh no! The yellow paint !

ياه ! انه دهان اصفر !

Oh no! The red paint !

ياه ! انه دهان احمر !



We can mix colors !

نستطيع أن نمزج الألوان !

This is for you Daddy.

هذه لك يا ابي.

This is for you Mommy.

هذه لك يا امي.

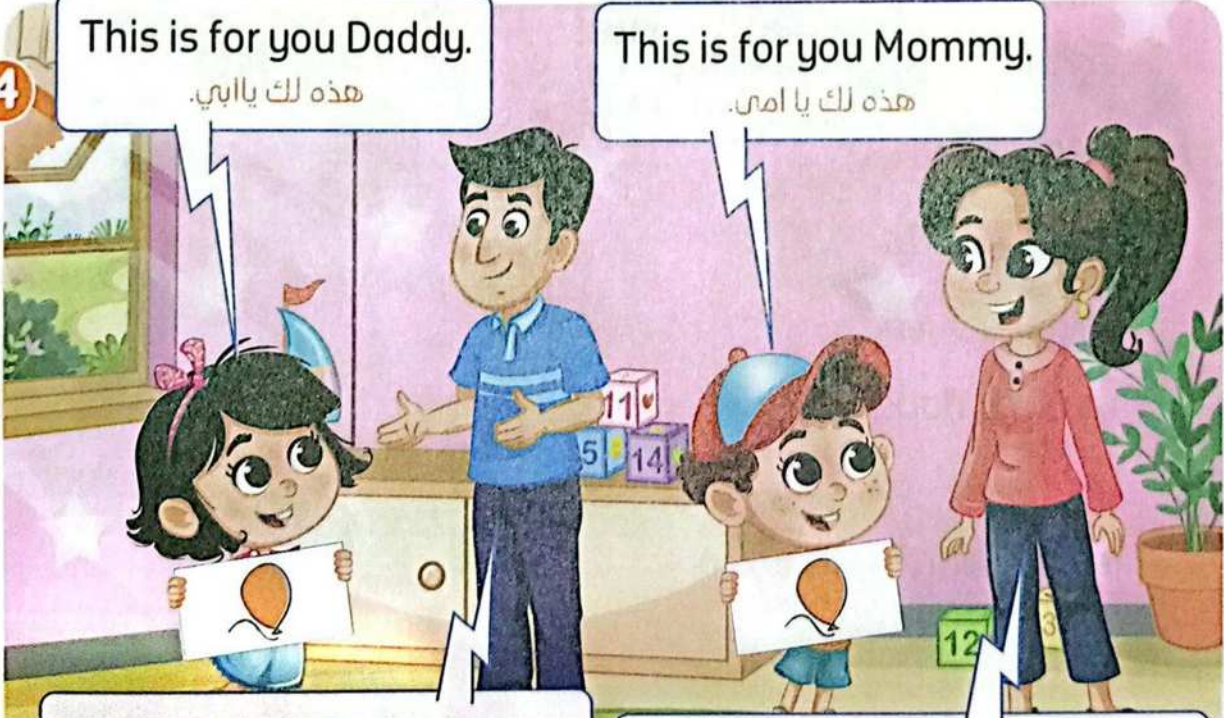

I like my balloon. It's orange.

احب بالونتي. لونها برتقالي.

I like my balloon. It's orange,

too! انها برتقالية اللون, ايضا !

# Review on UNIT 1

## parts of body



nose



mouth



hair



leg



arm



foot



eyes



ears

## family



daddy



mommy



brother



sister

## Color



red



blue



yellow



orange



brown



green

## Vocabulary

This is me!

## Language



This is my daddy.

This is my ear.

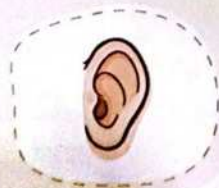

## Phonics

Bb



bag



Busy Bee

Hh



hand



hair



Hana

# Activities on Unit 1



1 Read and match. اقرأ وصل.

daddy

mouth

arm



2 Listen and tick [✓]. استمع وضع علامة (✓).

1.



yellow

green

2.



eye

hand

3 Listen and circle. استمع وضع دائرة.

1.



This is my daddy .  
mommy

2.



I see with my eyes .  
ears

3.



Red and yellow make orange .  
green

4.



I have two ears .  
legs

4 Look and complete. انظر واكمل.

red - I'm - legs

1.



I have two .....

2.



I like a ..... balloon.

5 Circle and write. ضع دائرة واكتب.

1.



- usy Bee

2.

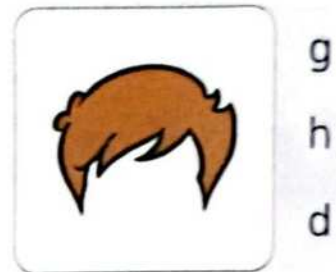

- air

6 Look and circle [✓] or [X]. انظر وضع دائرة حول علامة (✓) او (X).

1.

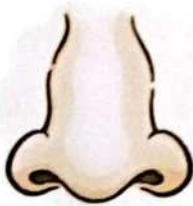

eye

✓ / X

2.



arm

✓ / X

3.



hand

✓ / X

7 Copy the following. انسخ الآتي.

• I have one nose.

.....  
-----  
.....

UNIT TWO

2

In my  
classroom

في فصلي الدراسي



## Unit 2 Objectives

By the end of the unit, your child will be able...

بنهاية هذه الوحدة، سيكون طفلك قادر على ...

### Lessons 1 , 2 & 3

- Objectives : 1. To identify classroom objects
- 2. To use "This is .." to talk about classroom objects

١- أن يتعرف على الأشياء الموجودة في الفصل

٢- أن يستخدم «هذا/ هذه ...» ليتكلم عن الأشياء الموجودة في حجرة الفصل

- Vocabulary : pencil, pen, eraser, sharpener, chair, table, board
- Language : • This is (an eraser), (a pen).
- What can you see ?

- قلم رصاص، قلم جاف، استيكة، براية، كرسي، منضدة، سبورة

- هذه (براية)، هذا (قلم).

- ماذا يمكنك أن ترى ؟

### Lessons 4 & 5

- Objectives : 1. To recognize numbers 1 to 10
- 2. To ask and answer "How many ...?"

١- أن يتعرف على الأرقام من ١ إلى ١٠

٢- أن يسأل ويجيب عن (كم عدد ... ؟)

- Vocabulary : one, two, three, four, five, six, seven, eight, nine, ten

- واحد، اثنين، ثلاثة، أربعة، خمسة، ستة، سبعة، ثمانية، تسعة، عشرة

- Language : How many pencils are there ? - There are ...

- كم عدد الأقلام الرصاص الموجودة ؟ - يوجد ...

### Lessons 6 & 7

- Objectives : 1. To identify shapes and know how many sides they have

١- أن يتعرف على الأشكال الهندسية ويعرف عدد الأضلاع

- 2. To write the names of known shapes

٢- أن يكتب أسماء الأشكال الهندسية المعروفة

- Vocabulary : circle, square, rectangle, triangle

- دائرة، مربع، مستطيل، مثلث

- Language : • A square has four sides.

- المربع له ٤ أضلاع.

- A circle is round.

- الدائرة مستديرة.

### Lesson 8

- Objectives : 1. To describe simple classroom objects
- 2. To draw and color classroom objects

١- أن يصف الأشياء البسيطة الموجودة في الفصل

٢- أن يرسم ويلون الأشياء الموجودة في الفصل

### Lessons 9 & 10

- Objectives : 1. To say and write M/m and N/n
- 2. To trace and write M/m and N/n

١- أن يقول ويكتب حرفي M/m ، N/n

٢- أن يتتبع ويكتب حرفي M/m ، N/n

- Vocabulary : mouth, classroom, nose, nurse, Nour, Maha, pen

- فم، فصل دراسي، أنف، ممرضة، نور، مها، قلم جاف

### Lessons 11 & 12

- Objectives : 1. To learn about people who help us at school
- 2. To learn and understand about what jobs people do

١- أن يتعلم عن الأشخاص الذين يساعدونا في المدرسة

٢- أن يتعلم ويفهم عن الوظائف التي يقوم بها الأشخاص

- Vocabulary : • teacher, librarian, nurse

- معلم (معلمة)، أمين (أمينة) مكتبة، ممرض (ممرضة)

- Language : • My teacher helps me write.

- يساعدني معلمي أن اكتب.

### Lesson 13

- Objectives : • To be able to listen to and follow a story

- أن يكون قادر على الاستماع واتباع القصة



## Vocabulary

★ Listen and repeat. استمع وردد.

chair كرسي



pencil قلم رصاص



table منضدة



classroom

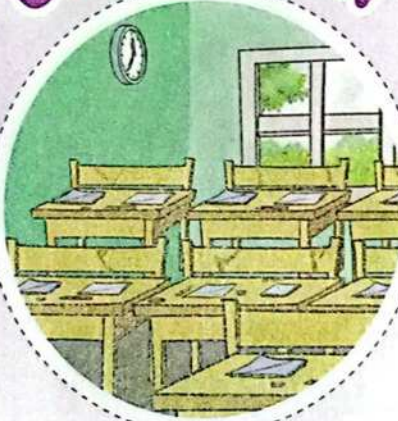

فصل دراسي

board سبورة



pen قلم جاف

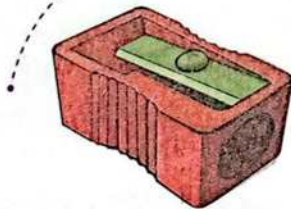

sharpener برآية

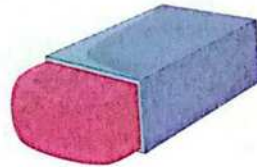

eraser أستيكة

★ Listen and look. استمع وانظر.



What can you see?

ماذا تستطيع ان تري؟



I can see a pen.

استطيع ان اري قلم جاف.



I can see an eraser.

استطيع ان اري استيكة.



I can see a table.

استطيع ان اري منضدة.

I can see a pencil.

استطيع ان اري قلم رصاص.



I can see a sharpener.

استطيع ان اري براءة.



I can see a chair.

استطيع ان اري كرسي.



Notes for parents

• Help your child to listen to the dialogue and look at the picture.

ساعد طفلك في الاستماع إلى المحادثة وينظر إلى الصورة.





★ Listen, trace and write. استمع، تتبع واكتب.

pen



pen

pencil



pencil

eraser



eraser

sharpener



sharpener

chair



chair

board



board

table



table

• Help your child to listen, trace the dotted words, then write it.

- ساعد طفلك أن يستمع، يتتبع الكلمات المكتوبة على شكل نقاط ثم يكتبها.

# Activities on lessons 1 & 2



1 Listen and circle. استمع وضع دائرة.

1. sharpener



2. pen



3. board

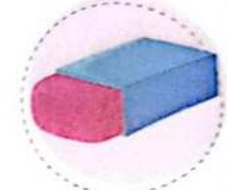
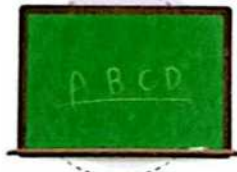

2 Listen and match. استمع وصل.

eraser

pencil

table

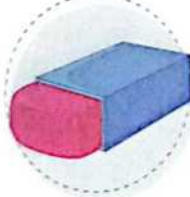
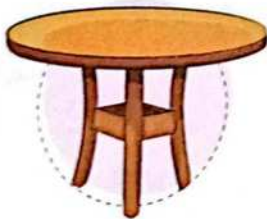

3 Look and circle [✓] or [X]. انظر وضع دائرة حول علامة (✓) أو (X).

1.



table

✓ / X

2.



pencil

✓ / X

3.



eraser

✓ / X

4 Look and tick (✓). انظر وضع علامة (✓).

1.  • pencil   
• eraser

2.  • chair   
• board

3.  • table   
• chair

4.  • sharpener   
• table

5 Trace and Color. تتبع ولون.

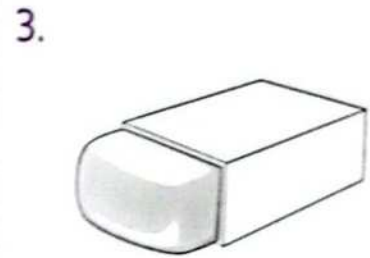
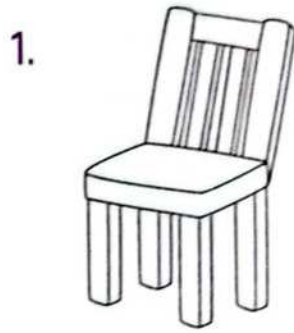

chair

pencil

eraser

6 Unscramble and write. اعد ترتيب الحروف واكتب.



n e p



l e b t a



n e p c i l

7 Trace. تتبع.

I can see an eraser.

1 This is ..... هذا / هذه (للمفرد القريب) ...

This is a / an singular noun / اسم مفرد

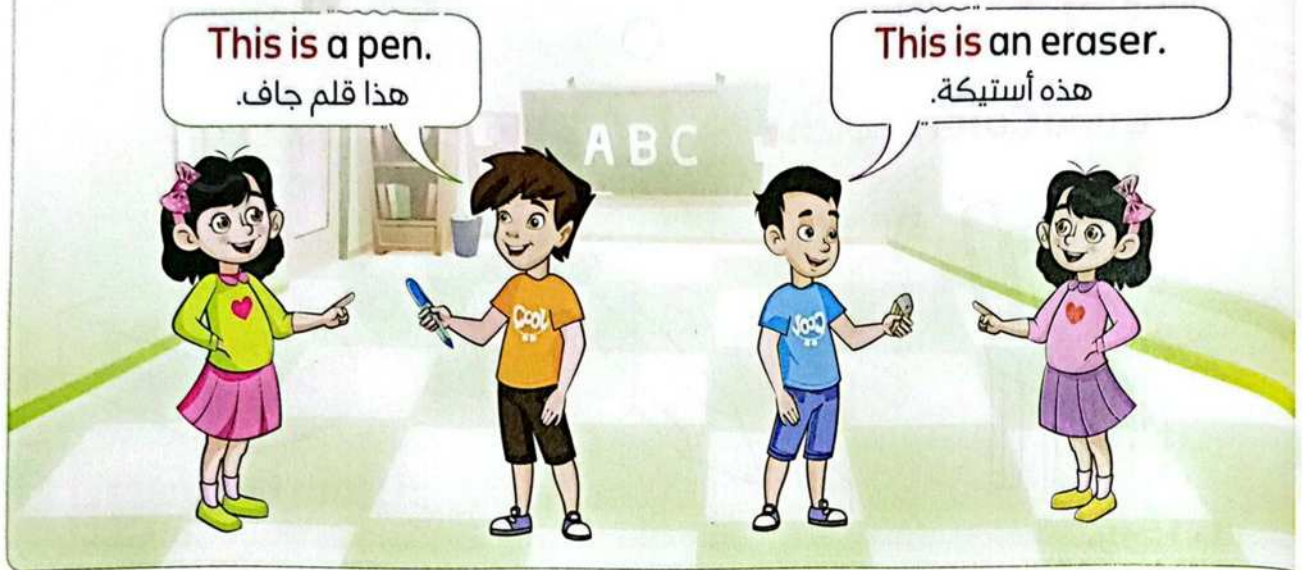

2 We use "a" before singular words beginning with a consonant sound. ٢. نستخدم "a" قبل الكلمات المفرد التي تبدأ بصوت ساكن.

Consonant



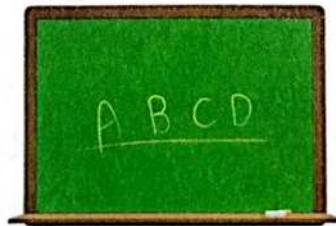

a board



a pencil

3 We use "an" before singular words beginning with a vowel sound.

٣. نستخدم "an" قبل الكلمات المفرد التي تبدأ بصوت متحرك.

Vowels

a e i o u

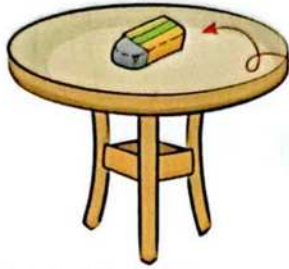

an eraser



☆ Activity ☆ Circle, trace and Color. ضع دائرة، تتبع ولون.

1.

a  
an

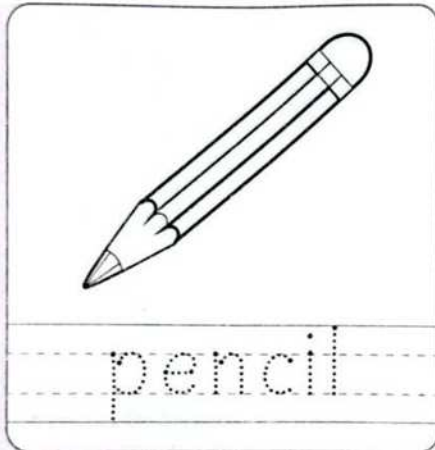

2.

a  
an



3.

a  
an

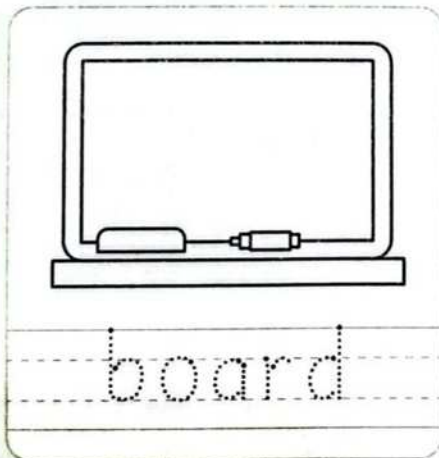

4.

a  
an



• Help your child circle (a) or (an), trace the dotted words and color the pictures.

- ساعد طفلك أن يضع دائرة حول (a) أو (an) ويتتبع الكلمات المكتوبة على شكل نقاط ثم يلون الصور.

# Activities on lesson 3



## 1 Color and write. لون واكتب.

1.



2.

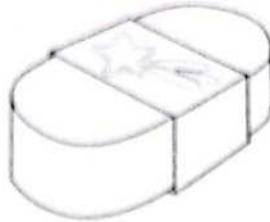

3.



## 2 Listen and circle. استمع وضع دائرة.

1.



This is a pen / pencil

2.



This is a table / board

3.



This is a sharpener / pen

4.



This is a board / pencil

## 3 Trace. تتبع.

This is a sharpener.

This is a board.



Vocabulary

★ Listen and repeat. استمع وردد.

NUMBERS الأرقام

1



one

2

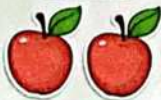

two

3



three

4



four

5

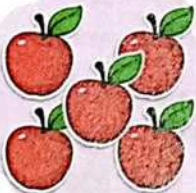

five

6

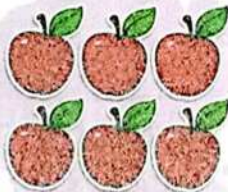

six

7

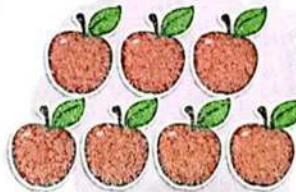

seven

8

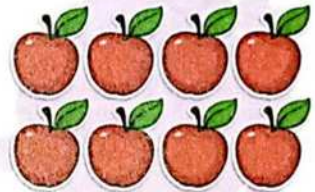

eight

9



nine

10

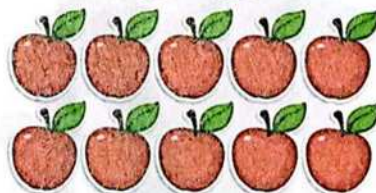

ten

## Language

1 There is + singular noun . يوجد (للمفرد).



2 There are + plural noun . يوجد (للجمع).



### Notes for parents

Unit 2

• Help your child to identify and use "There is ...." for singular noun and "There are ...." for plural nouns.

اعد طفلك ان يتعرف ويستخدم "There is + مفرد" بمعنى يوجد للمفرد و "There are + اسم جمع" بمعنى يوجد للجمع.



3 How many + اسم جمع يعبد ..... are there ? كم عدد ..... ؟

How many pencils are there ?  
كم عدد الأقلام الرصاص الموجودة ؟

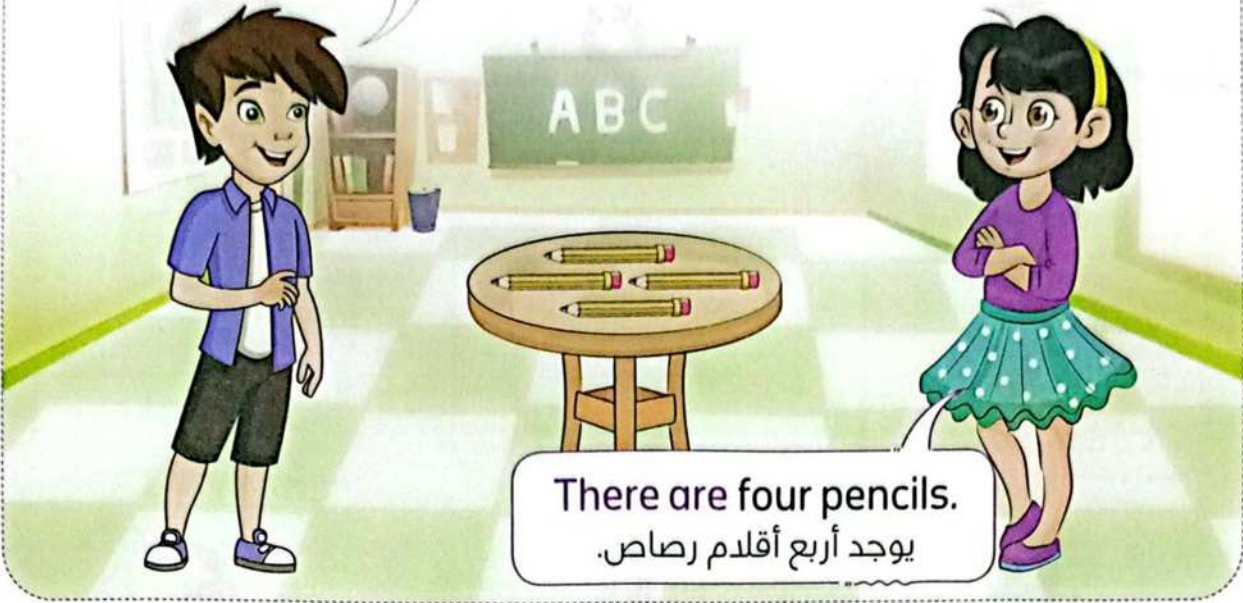

There are four pencils.  
يوجد أربع أقلام رصاص.

Activity

★ How many insects are there in each group ?

كم عدد الحشرات في كل مجموعة ؟

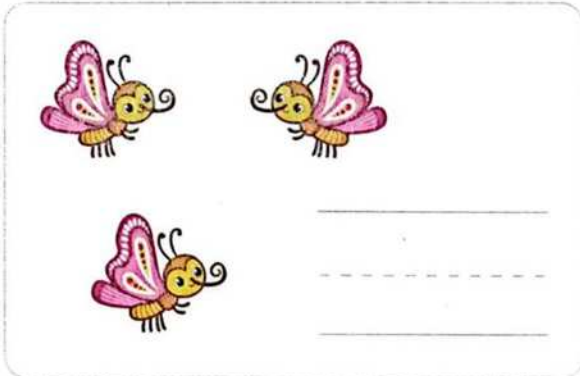
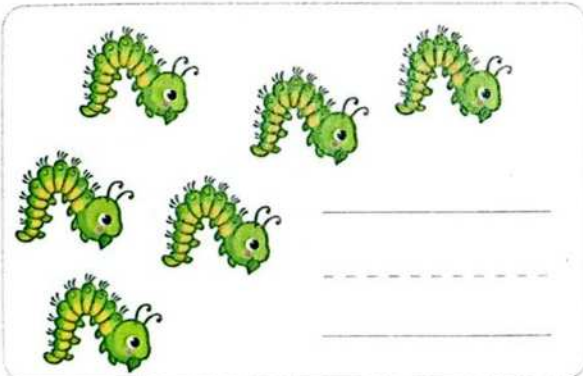
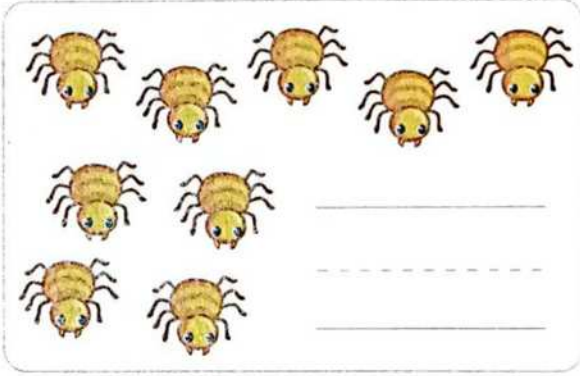
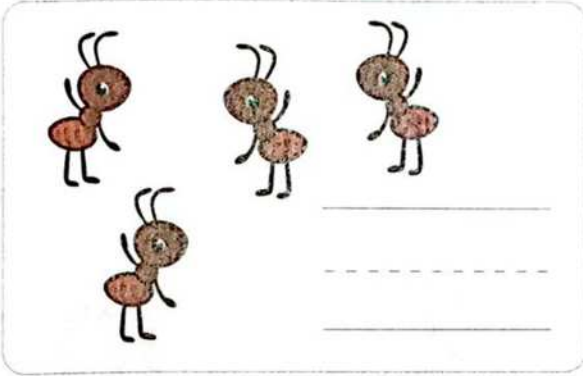

- Help your child to ask about numbers using "How many ?".
- Help your child to count the insects and write the number.

- ساعد طفلك أن يسأل عن العدد باستخدام "كم العدد ؟".
- ساعد طفلك أن يعد الحشرات ويكتب العدد.



★ Listen, trace and write. استمع، تتبع واكتب.

1

1

2

2

3

3

4

4

5

5

6

6

7

7

8

8

9

9

10

10

## Notes for parents

- Ask your child to listen and follow the arrows correctly to write the numbers from 1 to 10.

لب من طفلك ان يستمع ويتتبع الأسهم بشكل صحيح لكتابة الأرقام من 1 إلى 10.

★ Listen, trace and write. استمع، تتبع واكتب.

one

one

two

two

three

three

four

four

five

five

six

six

seven

seven

eight

eight

nine

nine

ten

ten

• Help your child to listen, trace the dotted words then write it.

- ساعد من طفلك ان يستمع ويتتبع الكلمات علي شكل نقاط ثم يكتبها.

# Activities on lessons 4 & 5



1 Listen and circle. استمع وضع دائرة.

1. seven



2. five



3. ten



2 Listen and match. استمع وصل.

eight

two

four



3 Listen and tick (✓). استمع وضع علامة (✓).

1.



nine

seven

2.



eight

six

**4 Color and write.** لون واكتب.

1.



2.



3.



**5 Listen and circle.** استمع وضع دائرة.

1.

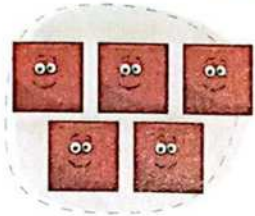

There are  $\frac{\text{five}}{\text{four}}$  squares.

2.

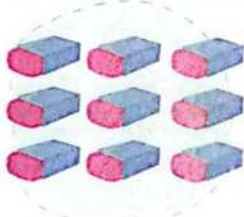

There are  $\frac{\text{eight}}{\text{nine}}$  erasers.

3.

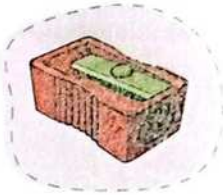

There  $\frac{\text{is}}{\text{are}}$  one sharpener.

**6 Listen and complete.** استمع واكمل.

seven - are - How

1.

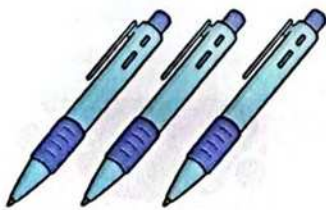

There ..... three pens.

2.



There are ..... balloons.



## Vocabulary

★ Listen and repeat. استمع وردد.

rectangle مستطيل



square مربع

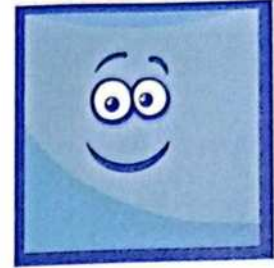

Shapes  
الأشكال

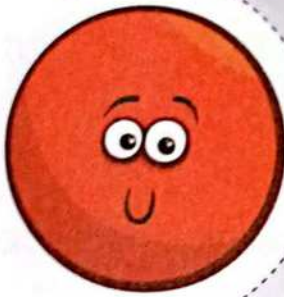

circle دائرة

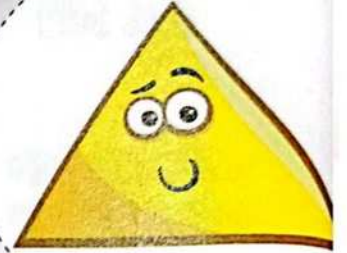

triangle مثلث



Activity 1 Color and write. لون واكتب.

1.

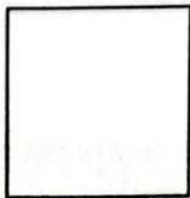

2.

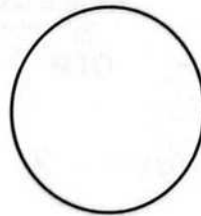

3.

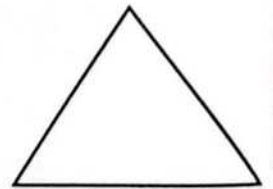

Notes for parents

1. Ask your child to trace the words and color the Shapes.

من طفلك أن يتتبع الكلمات ويلون الأشكال.

★ Activity 2 ★ Listen and trace. استمع وتتبع.

1

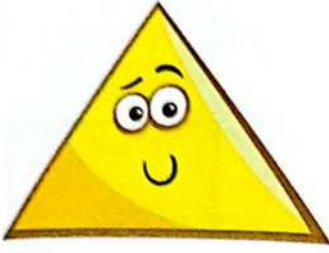

A triangle has **three sides**.  
المثلث لديه ثلاث جوانب.



2

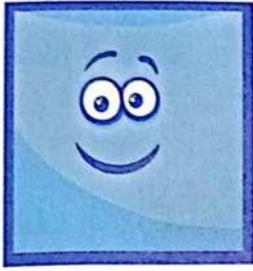

A square has four equal sides.  
المربع لديه 4 جوانب (أضلاع) متساوية.



3

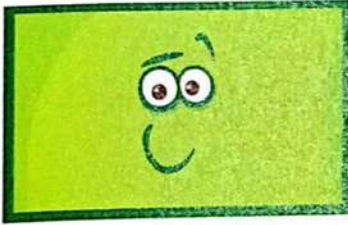

A rectangle has two short sides and two long sides.  
المستطيل لديه ضلعين قصيرين وضلعين طويلين.

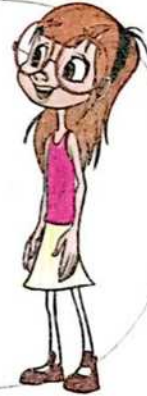

4



A circle is **round**.  
الدائرة لها شكل مستدير.



2. Ask your child to listen to the sentences and trace the words.

- اطلب من طفلك ان يستمع إلى الجمل ويتتبع الكلمات.

• Help your child identify the shapes and how many sides they have.

- ساعد طفلك في التعرف على الأشكال الهندسية ويعرف عدد الأضلاع في كل شكل.

# Activities on lessons 6 & 7



1 Listen and circle. استمع وضع دائرة.

1. One square

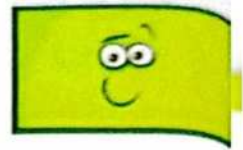

2. Two rectangles

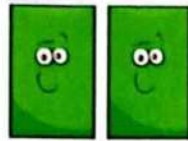

3. Three triangles

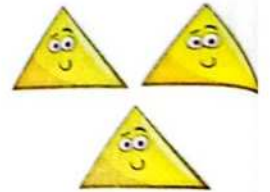
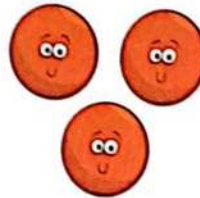

2 Listen and match. استمع وصل.

circle

square

triangle

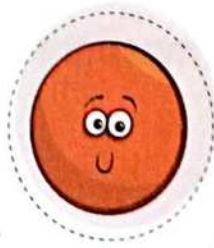

3 Listen and tick [✓]. استمع وضع علامة (✓).

1.



triangle

rectangle

2.



circle

square



4 Look and circle (✓) or (X). انظر وضع دائرة حول علامة (✓) أو (X).

1.

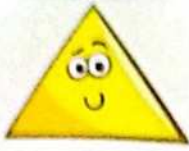

triangle

✓ / X

2.



square

✓ / X

3.



circle

✓ / X

5 Color and write. لون واكتب.

1.

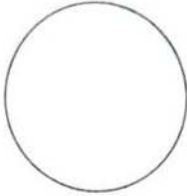

2.



3.

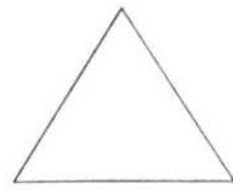

6 Listen and circle. استمع وضع دائرة.

1.



A  $\frac{\text{square}}{\text{circle}}$  has four equal sides.

2.

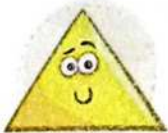

A triangle has  $\frac{\text{three}}{\text{four}}$  sides.

3.

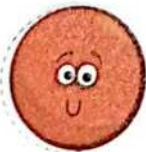

A  $\frac{\text{square}}{\text{circle}}$  is round.

4.



A rectangle has four  $\frac{\text{sides}}{\text{circles}}$ .

★ Look, listen and say. انظر، استمع وقل.

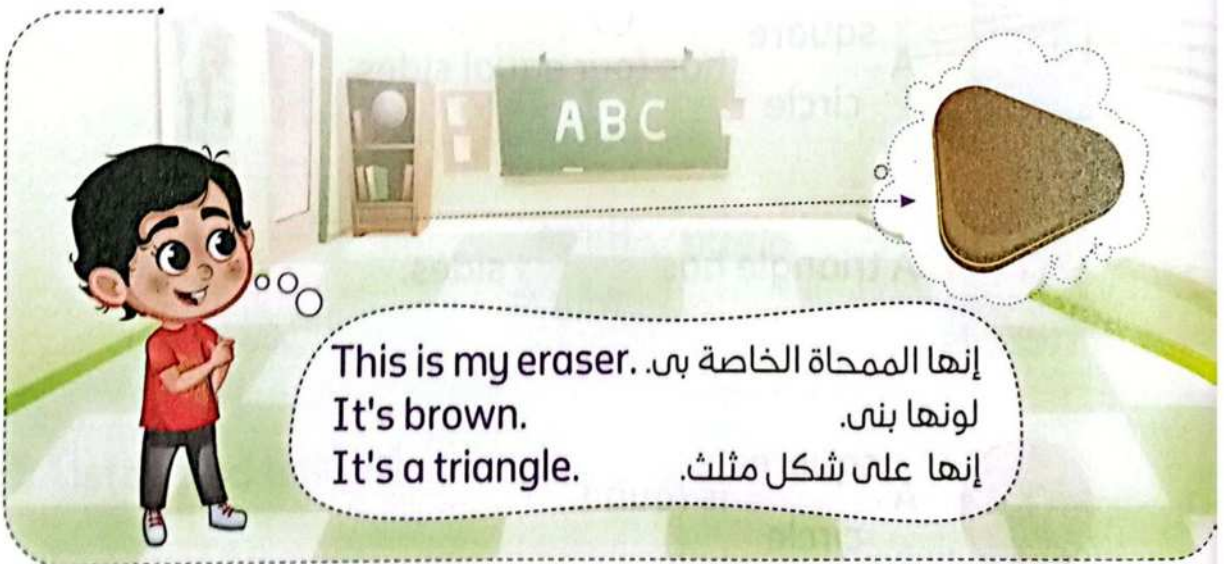

## Notes for parents

- Help your child describe items in his/her classroom according to shape and color.

اعد طفلك أن يصف اشياء داخل فصله الدراسي طبقاً للشكل واللون.

☆ Activity ★ Look, circle and Color. انظر ، ضع دائرة ولون.

1. The sharpener is a circle.

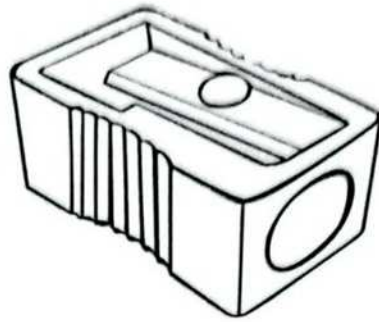

2. The eraser is a triangle.

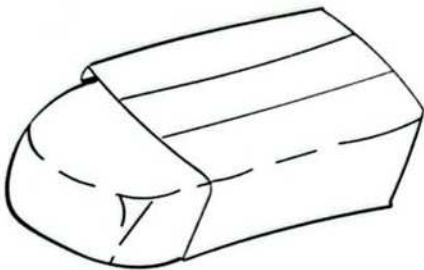

3. The board is a rectangle.

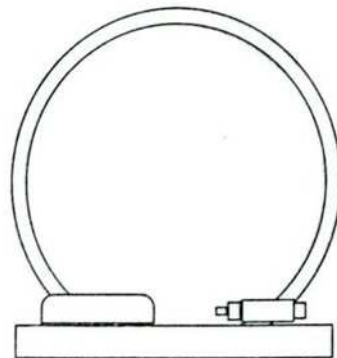
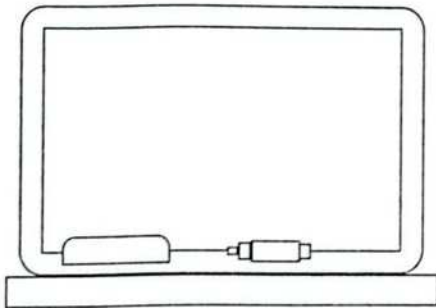

4. The table is a square.



• Help your child look at the pictures and circle the correct picture then color it.

- ساعد طفلك أن ينظر الى الصور و يضع دائرة حول الصورة الصحيحة ثم يلونها.

# Activities on lesson 8



1 Listen and circle. استمع وضع دائرة.

1. sharpener



2. square

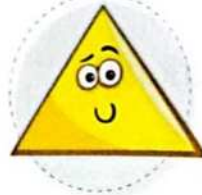
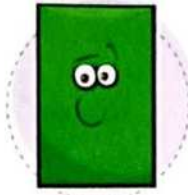

3. circle

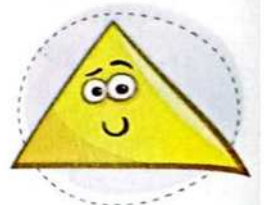
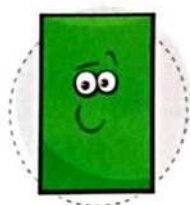

2 Listen and match. استمع وصل.

eraser

square

table

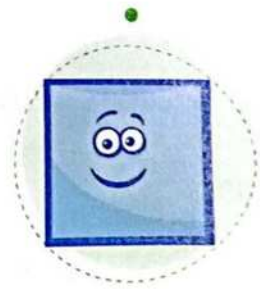
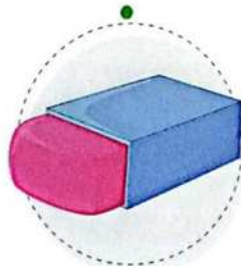
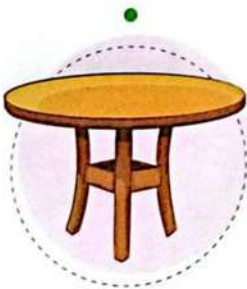

3 Listen and tick (✓). استمع وضع علامة (✓).

1.

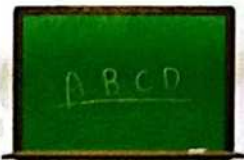

table

board

2.

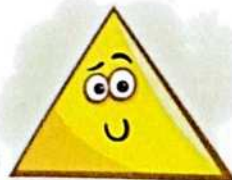

square

triangle



Vocabulary

★ Listen and repeat. استمع وردد.

classroom حجرة الدراسة



mouth فم

Maha مها



M m



Nour نور

N n



nurse ممرضة

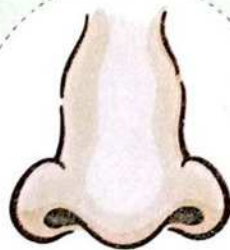

nose أنف

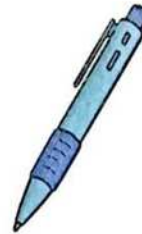

pen قلم جاف

• Help your child listen to the words that have / m / and / n / sounds and repeat them.

- ساعد طفلك ان يستمع إلى الكلمات التي تحتوى على الصوتين /m/ و /n/ ويرددها.

★ Listen and trace. استمع وتلعب



Mm Mm Mm



Maha classroom



Nn Nn Nn

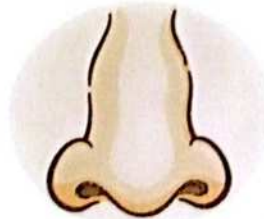

Nour nose nurse

Notes for parents

• Help your child listen to and identify the words that have /m/ and /n/ sounds, trace the words.

• عند طفلك على الاستماع إلى والتعرف على المفردات التي تبدأ بالصوتين /m/ ، /n/ ويتتبع الكلمات.

# Activities on lessons 9 & 10



1 Listen and circle. استمع وضع دائرة.

1. nurse



2. Maha



3. pen

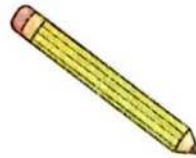

2 Read and match. اقرأ وصل.

mouth

pen

classroom



3 Listen and tick [✓]. استمع وضع علامة (✓).

1.



Nour

Maha

2.



table

classroom

**4 Circle and write.** ضع دائرة واكتب.

1.  n  
m  
t  
classroom -

2.  n  
b  
c  
pen -

**5 Trace.** تتبع.

1. M m M m M m M m

2. N n N n N n N n

**6 Listen and number.** استمع ورقم.

1. This is a mouth. ●



2. It is a pen. ●

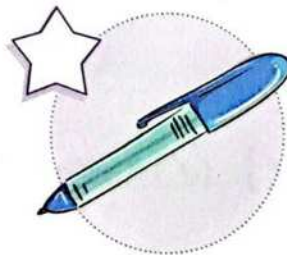

3. This is a classroom. ●

4. She is a nurse. ●





## Vocabulary

★ Listen and repeat. استمع وردد.

librarian أمينة مكتبة

teacher معلمة



nurse ممرضة



People who help us  
at school

الأشخاص الذين يساعدونا في المدرسة

★ Look, listen and trace. انظر ، استمع وتتبع.



My teacher  
helps me write.  
تساعدني معلمتي  
أن اكتب.



A nurse helps  
me feel better.  
تساعدني الممرضة  
أن اشعر بتحسن.



A librarian  
helps me find books.  
تساعدني أمينة المكتبة  
أن أجد الكتب.

• Help your child learn how to talk about people helping him/her at school.

– ساعد طفلك ان يتعلم كيف يتحدث عن الناس الذين يساعدوه في المدرسة.

# Sing and do

My teacher helps  
me write my name,

**Write my name, write my name.**

The teacher helps me write my  
name in my book.



The librarian helps  
me find books,

**Find books, find books.**

The librarian helps me  
find books in my library.

The nurse helps  
me feel better ,

**Feel better, feel better.**

The nurse helps me feel  
better so I go out to play.



★ Listen, look and trace. استمع ، انظر وتتبع.

1

My friend helps me  
with my sharpener.

يساعدني صديقي في استخدام برايتي.



2

My mommy helps me  
brush my teeth.

تساعدني أمي في غسل اسناني.



3

My teacher helps me  
with my math.

تساعدني معلمتي في شرح الرياضيات /  
واجب الرياضيات.



4

My daddy helps me  
with my bike.

يساعدني أبي في ركوب الدراجة الخاصة بي.



• Help your child listen to the sentences, look at the pictures and trace the words.

- ساعد طفلك أن يستمع إلى الجمل، ينظر إلى الصور ويتتبع الكلمات.

# Activities on lessons 11 & 12



1 Listen and circle. استمع وضع دائرة.

1. teacher



2. librarian



3. nurse



2 Listen and match. استمع وصل.

nurse

teacher

librarian



3 Listen and tick (✓). استمع وضع علامة (✓).

1.



librarian

nurse

2.



teacher

nurse

**4 Listen and circle.** استمع وضع دائرة.

1.



A nurse helps me  write  
 feel better

2.



A  nurse  
 librarian helps me find books.

**5 Look and circle [✓] or [X].** انظر وضع دائرة حول علامة (✓) او (X).

1.



teacher

/

2.



nurse

/

3.



librarian

/

**6 Look, listen and complete.** انظر، استمع واكمل.

nurse - books - teacher

1.



My ..... helps me write.

2.



A librarian helps me find .....

Dina gets ready for school !

دينا تستعد للمدرسة !

We can help each other !

نستطيع مساعدة بعضنا البعض !



★ Listen and look. استمع وانظر.



• Help your child listen to the scenes of the story and look at the pictures.

- ساعد طفلك في الاستماع إلى مشاهد القصة والنظر إلى الصور.





5

Which pens do you want ?  
أى أقلام جاف تريدين ؟

I want one pen - my blue pen.  
أريد قلم جاف واحد - قلمي الجاف الأزرق.

Can you help ?  
Can you see Dina's blue pen ?  
هل تستطيع أن تساعدني ؟  
هل تستطيع أن ترى قلم دينا الأزرق ؟

I can't see your blue pen.  
انا لا أرى قلمك الجاف الأزرق.

6



☆ Activity ☆ Listen and Color. استمع ولون.



Notes for parents

- Help your child listen to the sentence and color the pencils according to the given sentence.

• نطلبك في الاستماع إلى الجملة وتلوين الأقلام الرصاص طبقاً للجملة المعطاة.

# Activities on lesson 13



## 1 Listen and circle. استمع وضع دائرة.

1. red square



2. green triangle

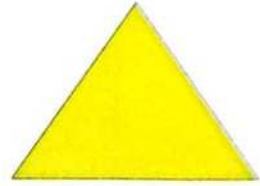

3. blue circle



## 2 Listen and match. استمع وصل.

round sharpener

red rectangle

blue triangle

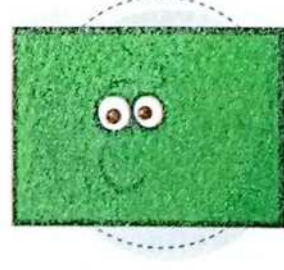
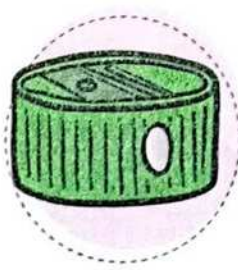
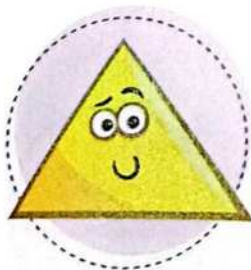

## 3 Listen and tick [✓]. استمع وضع علامة (✓).

1.



green

blue

2.



pencil

ruler

4 Trace and Color. تتبع ولون.

1.

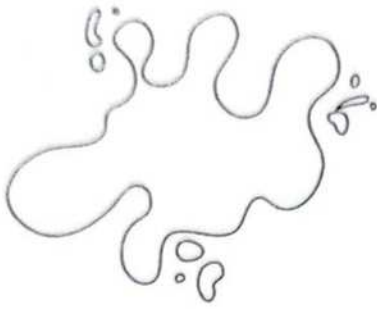

blue

2.



sharpener

3.

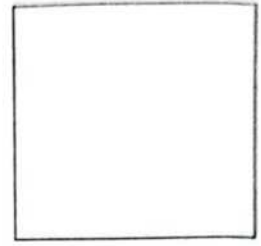

square

5 Trace and circle. تتبع وضع دائرة.

1.



c  
s  
y

yellow

2.

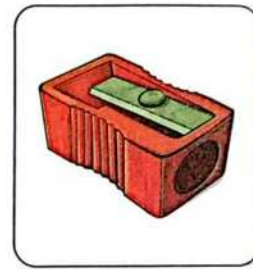

c  
s  
r

sharpener

6 Look and circle. انظر وضع دائرة.

1.



square  
triangle

2.



classroom  
school

3.

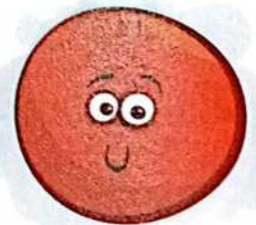

circle  
rectangle

# Review on UNIT 2

## Classroom items

pencil



pen



eraser



sharpener

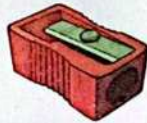

board



## shapes

triangle

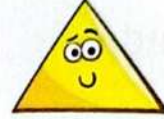

square



rectangle

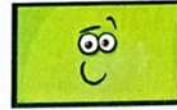

circle



Vocabulary

In my classroom

Language

Phonics



- There is one pencil.

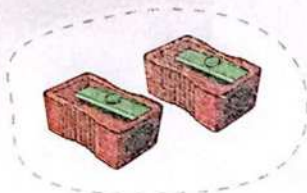

- There are two sharpeners.

Mm



mouth



Maha

Nn



nurse

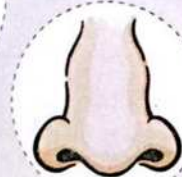

nose



Nour

# Activities on Unit 2



1 Listen and circle. استمع وضع دائرة.

1. board



2. triangle

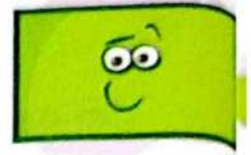
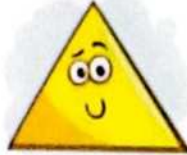

3. eight

9

6

8

2 Listen and match. استمع وصل.

table

five

circle

5



3 Listen and tick (✓). استمع وضع علامة (✓).

1.



board

table

2.



teacher

nurse

4 Look and circle (✓) or (X). انظر وضع دائرة حول علامة (✓) او (X).

1.



eraser

✓ / X

2.



nine

✓ / X

3.

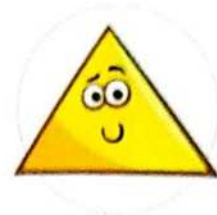

triangle

✓ / X

5 Color and write. لون واكتب.

1.

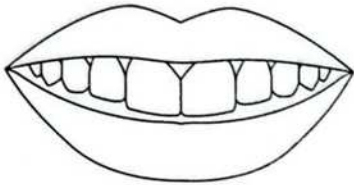

\_\_\_\_\_

-----

\_\_\_\_\_

2.



\_\_\_\_\_

-----

\_\_\_\_\_

3.



\_\_\_\_\_

-----

\_\_\_\_\_

6 Circle and write. ضع دائرة واكتب.

1.

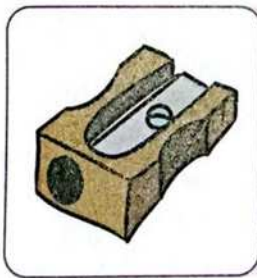

c  
s  
r

\_harpener

2.

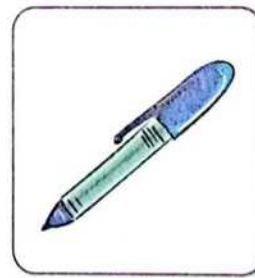

c  
d  
p

\_en

7 Copy the following. انسخ الآتي.

• My teacher helps me.

\_\_\_\_\_

-----

\_\_\_\_\_

2

THEME

The world  
around me

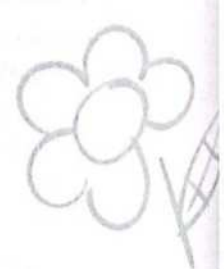
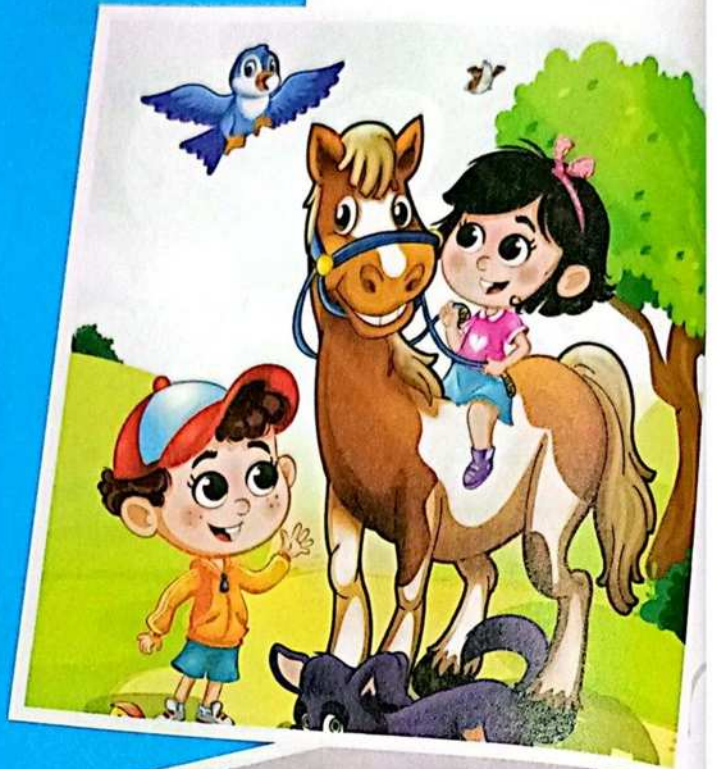



3

UNIT THREE

# Our Animals

حيواناتنا



## Unit 3 Objectives

By the end of the unit, your child will be able...

بنهاية هذه الوحدة، سيكون طفلك قادر على ...

### Lessons 1 & 2

- Objectives : • To identify domestic, farm and other regionally familiar animals

١- أن يتعرف على حيوانات المزرعة التي تربي في المنزل وحيوانات البيفة الأخرى

- Vocabulary : • sheep, rabbit, frog, fish, horse, camel, cat جمل، قطة

### Lessons 3 & 4

- Objectives : 1. To determine some of animals habitats : land / water  
2. To know which animals live on land and which in water

١- أن يحدد (بيئات) الحيوانات : اليابسة/الماء

- Language : • Where do camels live ?

٢- أين تعيش الجمال ؟

- Camels live on land.

٣- الجمال تعيش على اليابسة.

### Lessons 5 & 6

- Objectives : • To differentiate between living and non-living things

١- أن يفرق بين الكائنات الحية والغير حية

- Language : • Living things eat, breathe and grow.

٢- الكائنات الحية تأكل، تتنفس وتنمو.

- Non-living things don't eat, don't breathe, don't grow.

٣- الكائنات الغير حية لا تأكل، لا تتنفس ولا تنمو.

### Lessons 7 & 8

- Objectives : 1. To identify your favorite animal

١- أن تتعرف على حيوانك المفضل

- 2. To read about looking after animals

٢- أن يقرأ عن كيفية الاعتناء بالحيوانات

### Lessons 9 & 10

- Objectives : 1. To recognize and produce the letters sounds /p/ and /r/

١- أن يتعرف على نطق أصوات /p/ و /r/

- 2. To find words with /p/ and /r/

٢- أن يجد كلمات بصوت /p/ و /r/

- 3. To trace and copy letters (P,p) and (R,r)

٣- أن يتتبع وينسخ حرف (P,p) و (R,r)

- Vocabulary : • panda, Pyramids, playground, pen, Peter, red, sharpener, run, rabbit, Reem

- حيوان الباندا، الاهرامات، ملعب، قلم جاف، بيتر، لون احمر، براية، يجري، أرنب، ريم

### Lessons 11 & 12

- Objectives : 1. To recognize the human and animal life cycles

١- أن يتعرف على دورة الحياة الخاصة بالإنسان والحيوان

- 2. To identify the life cycle of an animal (a frog)

٢- أن يتعرف على دورة الحياة الخاصة بالحيوان (الضفدع)

- Vocabulary : baby, child, teenager, adult, eggs, baby frog , adult frog

- رضيع، طفل، مراهق، بالغ، بيض، ضفدع صغير، ضفدع بالغ

### Lesson 13

- Objectives : • To revise the stages of life for animals, especially a frog

- أن يراجع دورة الحياة الخاصة بالحيوانات بالأخص الضفدع

- Vocabulary : • living thing , water, food

- الكائن الحي، ماء، طعام



## Vocabulary

★ Listen and repeat. استمع وردد.

sheep خروف



rabbit أرنب



cat قطة



frog ضفدع



animals  
حيوانات



camel جمل



fish سمكة

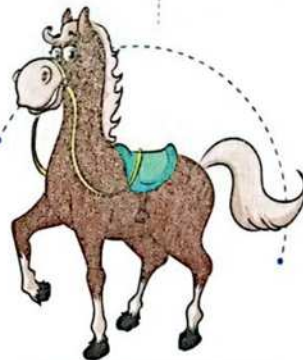

horse حصان

☆ Listen and look. استمع وانظر.



What can you see?  
ماذا تستطيع ان تربي؟



I can see a cat.  
استطيع ان اربي قطة.



I can see a camel.  
استطيع ان اربي جمل.



I can see a fish.  
استطيع ان اربي سمكة.



I can see a rabbit.  
استطيع ان اربي ارنب.



I can see a frog.  
استطيع ان اربي ضفدع.



I can see a sheep.  
استطيع ان اربي خروف.



I can see a horse.  
استطيع ان اربي حصان.



Notes for parents

Unit 3

• Help your child listen to the dialogue and look at the picture.

• طفلك في الاستماع إلى المحادثة وينظر إلى الصورة.



★ Listen, trace and write. استمع، تتبع واكتب.

sheep



sheep

rabbit



rabbit

frog



frog

cat



cat

camel



camel

fish



fish

horse



horse

• Help your child to listen, trace the dotted words, then write it.

- ساعد طفلك أن يستمع ، يتتبع الكلمات المكتوبة على شكل نقاط ثم يكتبها .

# Activities on lessons 1 & 2



1 Listen and circle. استمع وضع دائرة.

1. horse



2. fish



3. frog



2 Listen and match. استمع وصل.

sheep

cat

rabbit



3 Listen and tick [✓]. استمع وضع علامة (✓).

1.



frog

fish

2.



horse

sheep

4 Unscramble and write. اعد ترتيب الحروف واكتب.

1.



o h r s e

\_\_\_\_\_

-----

\_\_\_\_\_

2.



a c m l e

\_\_\_\_\_

-----

\_\_\_\_\_

3.



b i b r a t

\_\_\_\_\_

-----

\_\_\_\_\_

5 Color and write. لون واكتب.

1.

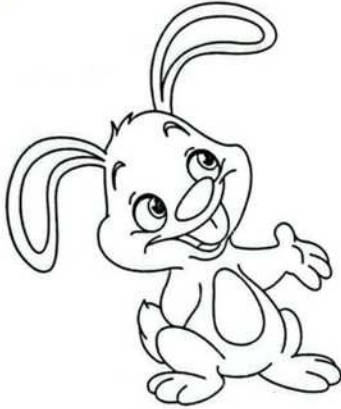

2.



3.

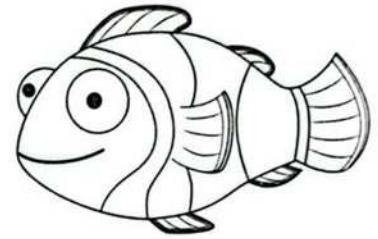

6 Circle and write. ضع دائرة واكتب.

1.

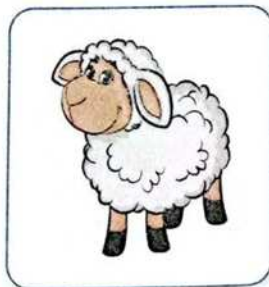

s  
m  
d

\_ heep

2.

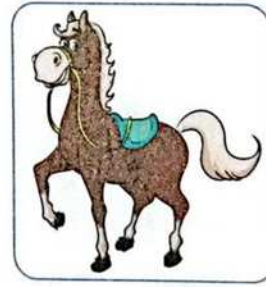

m  
h  
s

\_ orse



Vocabulary

★ Listen and repeat. استمع وردد.



land يابسة (أرض)



water ماء

Language

★ Where do camels / fish live ?

• أين تعيش الجمال / الأسماك ؟



الجمال تعيش على اليابسة. Camels live on land.



السمك يعيش في الماء. Fish live in water.

Notes for parents

• Help your child know where animals live.

• طفلك أن يعرف أين تعيش الحيوانات.



☆ Activity ☆ انظر وصل. Look and match.

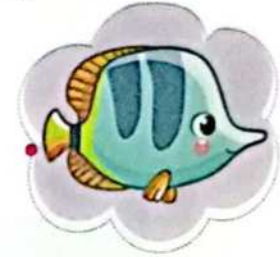

• Help your child to look and match each animal to its habitat.

- ساعد طفلك أن ينظر و يصل كل حيوان بموطنه / بيئته.

# Sing and do

Do you know where camels live,  
camels live, camels live?  
Do you know where camels live,  
camels live, camels live?  
Yes, I know where camels live,  
camels live, camels live.  
Yes, I know where camels live,  
camels live, camels live.  
They live on **LAND**.



Do you know where fish live, fish  
live, fish live?  
Do you know where fish live, fish  
live, fish live?  
Yes, I know where fish live,  
fish live, fish live.  
Yes, I know where fish live,  
fish live, fish live.  
They live in **WATER**.



## Notes for parents

Unit 3

- Sing with your child.

# Activities on lessons 3 & 4



1 Listen and circle. استمع وضع دائرة.

1. land



2. sheep



2 Listen and match. استمع وصل.

horse

frog

fish

camel



3 Listen and tick (✓). استمع وضع علامة (✓).

1.



land

water

2.



rabbit

fish

4 Look and circle (✓) or (X). انظر وضع دائرة حول علامة (✓) او (X).

1.



fish

✓ / X

2.



water

✓ / X

3.



horse

✓ / X

5 Circle and write. ضع دائرة واكتب.

1.



k

s

c

\_at

2.



v

w

y

\_ater

6 Listen and circle. استمع وضع دائرة.

1.



Rabbits live on . land ..  
water

2.



Fish live in . land ..  
water

3.



Fish . live on land.  
Cats

4.



Camels live on . land ..  
water

7 Trace. تتبع.

Sheep live on land.



Vocabulary

★ Look and listen. انظر واستمع.



non-living things الأشياء غير الحية

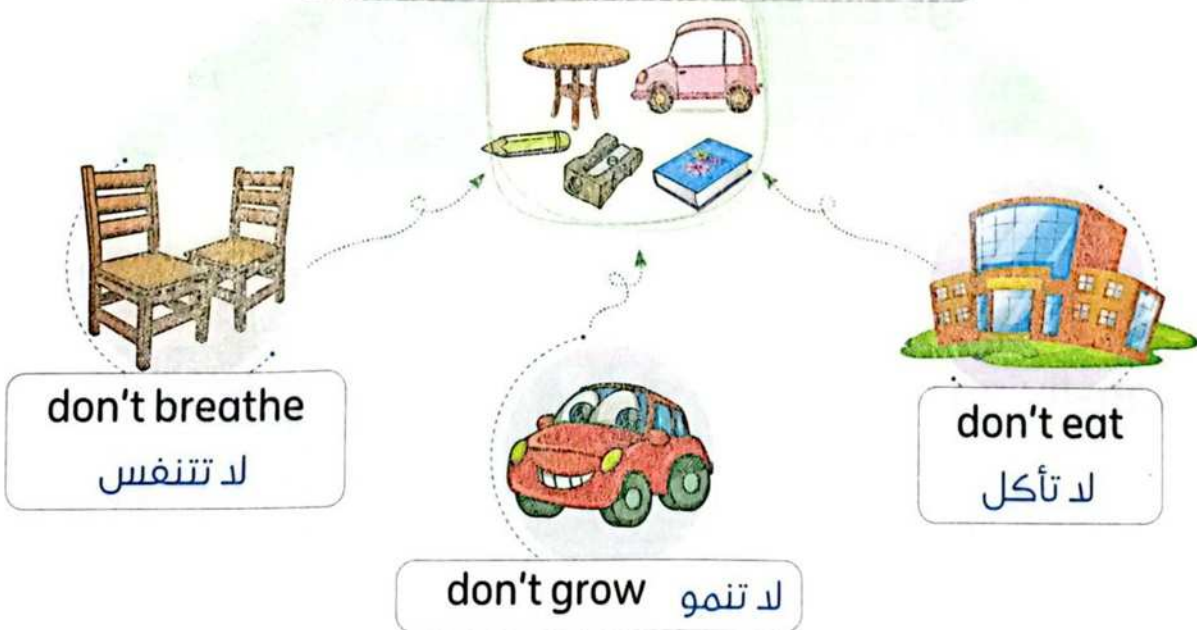

• Help your child differentiate between living things and non-living things.

- ساعد طفلك ان يفرق بين الكائنات الحية والأشياء غير الحية.

انظر . استمع وتتبع . ★ Activity 1 ★ Look, listen and trace.

Living things eat.



Living things grow.



Living things breathe.

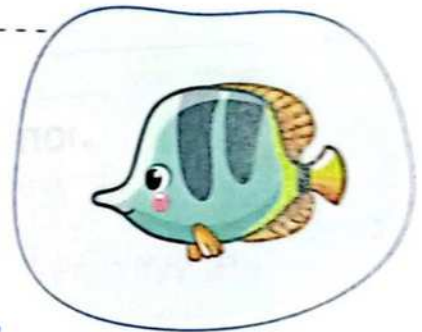

Non-living things don't eat.



Notes for parents

1. Help your child look at the pictures, listen to the sentences and trace the dotted words.

مطلبتك أن ينظر إلى الصور، يستمع إلى الجمل ويتتبع الكلمات المكتوبة على شكل نقاط.

## Activity 2

★ Color the circle of living things in red, and non-living things in green.

لون دائرة الكائنات الحية باللون الأحمر والكائنات الغير حية باللون الأخضر.

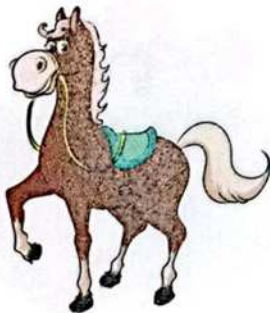
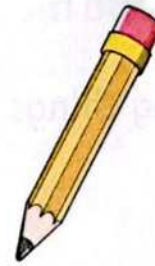
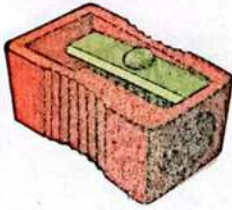

2. Help your child to color the circle of living things in red and non-living things in green.

- ساعد طفلك أن يلون دائرة الكائنات الحية باللون الأحمر والكائنات الغير حية باللون الأخضر.

# Activities on lessons 5 & 6



1 Listen and circle. استمع وضع دائرة.

1. non-living thing



2. eat



2 Listen and match. استمع وصل.

living things

sheep

non-living



3 Listen and tick [✓]. استمع وضع علامة (✓).

1.



living things

non-living things

2.

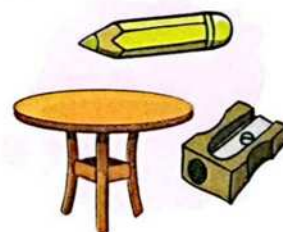

grow

don't grow





Vocabulary

★ Listen and repeat. استمع وردد.

love يحب

look after يعتني بـ



panda ذب الباندا



Language



Talking about your favorite animal.

التحدث عن حيوانك المفضل.

What's your favorite animal?  
ما هو حيوانك المفضل؟



My favorite animal is the cat.  
حيواني المفضل هي القطعة.



• Help your child ask and answer questions about his/ her favorite animals.

- ساعد طفلك ان يسأل ويجيب أسئلة عن حيوانه/حيوانها المفضل.

★ Look and listen. انظر واستمع.



Mango is my cat.  
مانجو قطتي.



She eats.  
هي تأكل.



She grows.  
هي تنمو.



I love Mango!  
أنا أحب مانجو!



I look after Mango.  
أنا أعتني بمانجو.

★ Activity انظر، استمع وضع علامة (✓). ★ Look, listen and tick [✓].

1.



Mango eats.

2.



Mango doesn't grow.

3.



I look after Mango.

4.



Mango doesn't eat.

5.



Mango grows.

6.



I don't look after Mango.

Notes for parents

Unit 3

- Help your child look at the pictures and listen to the sentences. ساعد طفلك في النظر إلى الصور والاستماع إلى الجمل.
- Help your child look, listen and tick (✓) the suitable sentence. ساعد طفلك أن ينظر، يستمع ويضع علامة (✓) للجمل المناسبة.

# Sing and do

There is a girl who has a cat  
Has a cat, has a cat.



There is a girl who has a cat  
And its name is Mango.



There is a boy who has a horse  
Has a horse, has a horse.



There is a boy who has a horse  
And its name is Billy.



• Sing with your child.

- غن مع طفلك.

# Activities on lessons 7 & 8



1 Listen and circle. استمع وضع دائرة.

1. animal



2. camel



2 Read and match. اقرأ وصل.

fish

frog

horse



3 Look and tick (✓). انظر وضع علامة (✓).

1.



puppy

camel

2.



fish

panda

4 Look and circle (✓) or (X). انظر وضع دائرة حول (✓) او (X).

1.



cat

✓ / X

2.



sheep

✓ / X

3.



love

✓ / X

5 Look and complete. انظر واكمل.

horse - panda - camel - fish

1.



My favorite animal is the .....

2.



It's a .....

3.



It's a .....

4.



My favorite animal is the .....

6 Copy the following. انسخ الآتي.

• I love my horse.

.....  
.....  
.....



Phonics

★ Listen and repeat. استمع وردد.

Pyramids اهرامات

panda دُب الباندا



playground ملعب



pen قلم جاف

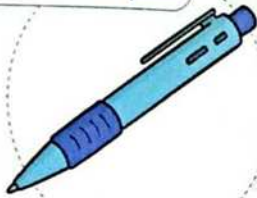

P p

Peter بيتر



red لون احمر

R r



Reem رييم

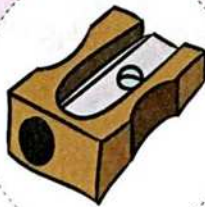

sharpener برآية



run يجري



rabbit ارنب

Notes for parents

• Help your child listen to the words that have the /p/ and /r/ sounds and repeat them.

تم طفلك أن يستمع إلى الكلمات التي تحتوي على الصوتين /p/ و /r/ ويردها.



# Writing

★ Listen and trace. استمع وتتبع.

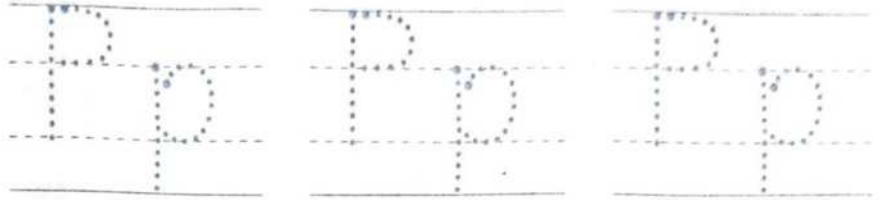
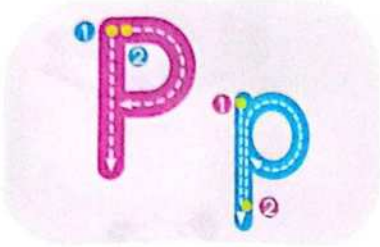

Pyramids

playground

panda

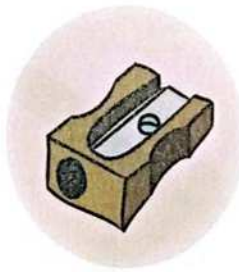
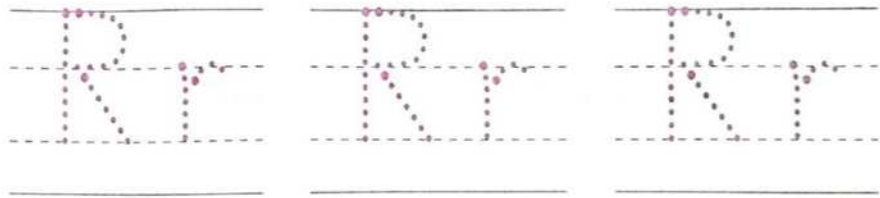
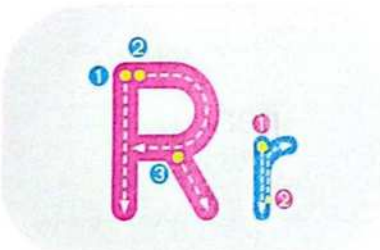

Reem

sharpener

rabbit

• Ask your child to listen and trace the letters (Pp), (Rr) and the dotted words.

- اطلب من طفلك أن يستمع ويتتبع الحرفين (Pp) و (Rr) والكلمات المكتوبة على شكل نقاط.

# Activities on lessons 9 & 10



1 Listen and circle. استمع وضع دائرة.

1. Peter



2. panda



3. run



2 Read and match. اقرأ وصل.

Pyramids

Reem

pen



3 Listen and tick (✓). استمع وضع علامة (✓).

1.



Reem

Peter

2.



panda

cat



**4** Look and circle (✓) or (X). انظر وضع دائرة حول علامة (✓) او (X).

1.



pen

✓ / X

2.



run

✓ / X

3.



camel

✓ / X

**5** Color and write. لون واكتب.

1.

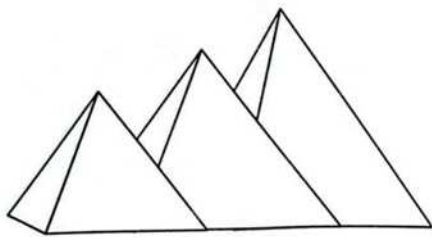

\_\_\_\_\_

-----

\_\_\_\_\_

2.



\_\_\_\_\_

-----

\_\_\_\_\_

3.



\_\_\_\_\_

-----

\_\_\_\_\_

**6** Look, read and circle. انظر ، اقرأ وضع دائرة.

1.



panda

camel

2.



book

pen

3.



Pyramids

playground



## Vocabulary

★ Listen and repeat. استمع وردد.

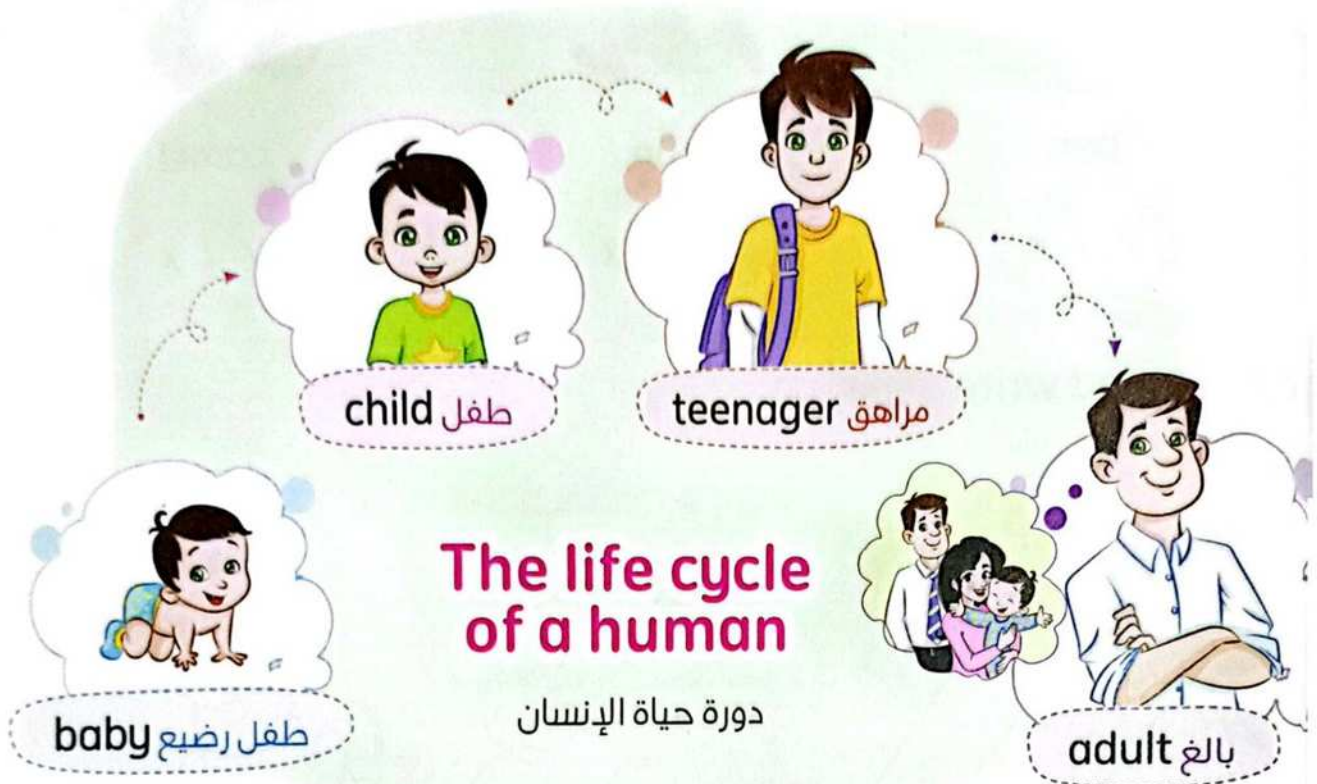

## Activity

★ Trace and Color. تتبع ولون.

1.



teenager

2.



baby

3.



child

## Notes for parents

- Help your child know the lifecycle of human.
- Ask your child to trace the words and color the picture.

عند طفلك ان يعرف دورة حياة الإنسان.  
لبمن طفلك ان يتتبع الكلمات ويلون الصور.

# The lifecycle of an animal

دورة حياة حيوان



## Activity 1 Color and trace. لون وتتبع.

1.

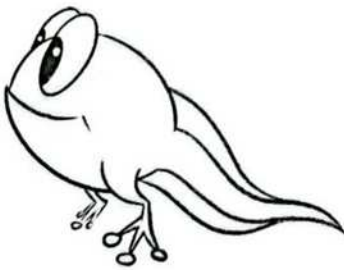

baby frog

2.



adult frog

3.

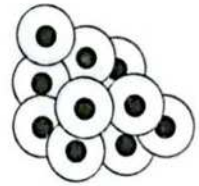

eggs

1. Help your child to identify the lifecycle of frogs.

- ساعد طفلك أن يتعرف على دورة حياة الضفدع.

# Activities on lessons 11 & 12



1 Listen and circle. استمع وضع دائرة.

1. baby



2. teenager



3. adult



2 Listen and match. استمع وصل.

child

adult

baby



3 Listen and tick [✓]. استمع وضع علامة (✓).

1.



baby

adult

2.



child

adult

4 Look and circle (✓) or (X). انظر وضع دائرة حول علامة (✓) او (X).

1.



child

✓ / X

2.



baby

✓ / X

3.



adult

✓ / X

5 Color and write. لون واكتب.

1.



\_\_\_\_\_

-----

\_\_\_\_\_

2.



\_\_\_\_\_

-----

\_\_\_\_\_

3.



\_\_\_\_\_

-----

\_\_\_\_\_

6 Look and circle. انظر وضع دائرة.

1.



baby

adult

2.



child

teenager

3.

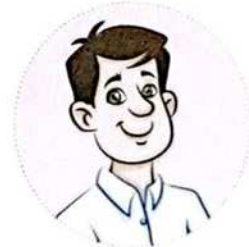

adult

child

7 Match each adult to its baby. صل كل بالغ بصغيره.

## Adults

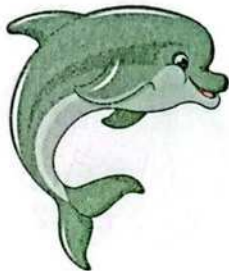

## Babies

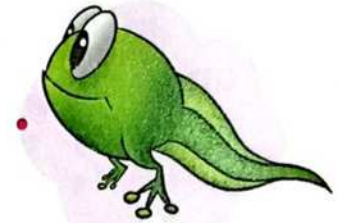
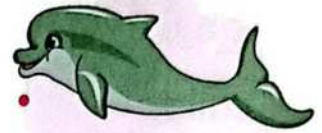

**A baby frog !**

ضفدع رضيع !

**We are kind to animals !**

نحن عطوفين على الحيوانات !



★ Listen and look. استمع وانظر.





3

The baby frog is a living thing.

الضفدع الرضيع كائن حي.



Does it grow ?

هل ينمو ؟

4

Yes, it grows to be an adult frog.

نعم ، إنه ينمو ليصبح ضفدع بالغ.



5



How can we help the baby frog ?

كيف نستطيع ان نساعد الضفدع الرضيع ؟

What do frogs need?

ماذا تحتاج الضفادع؟

6

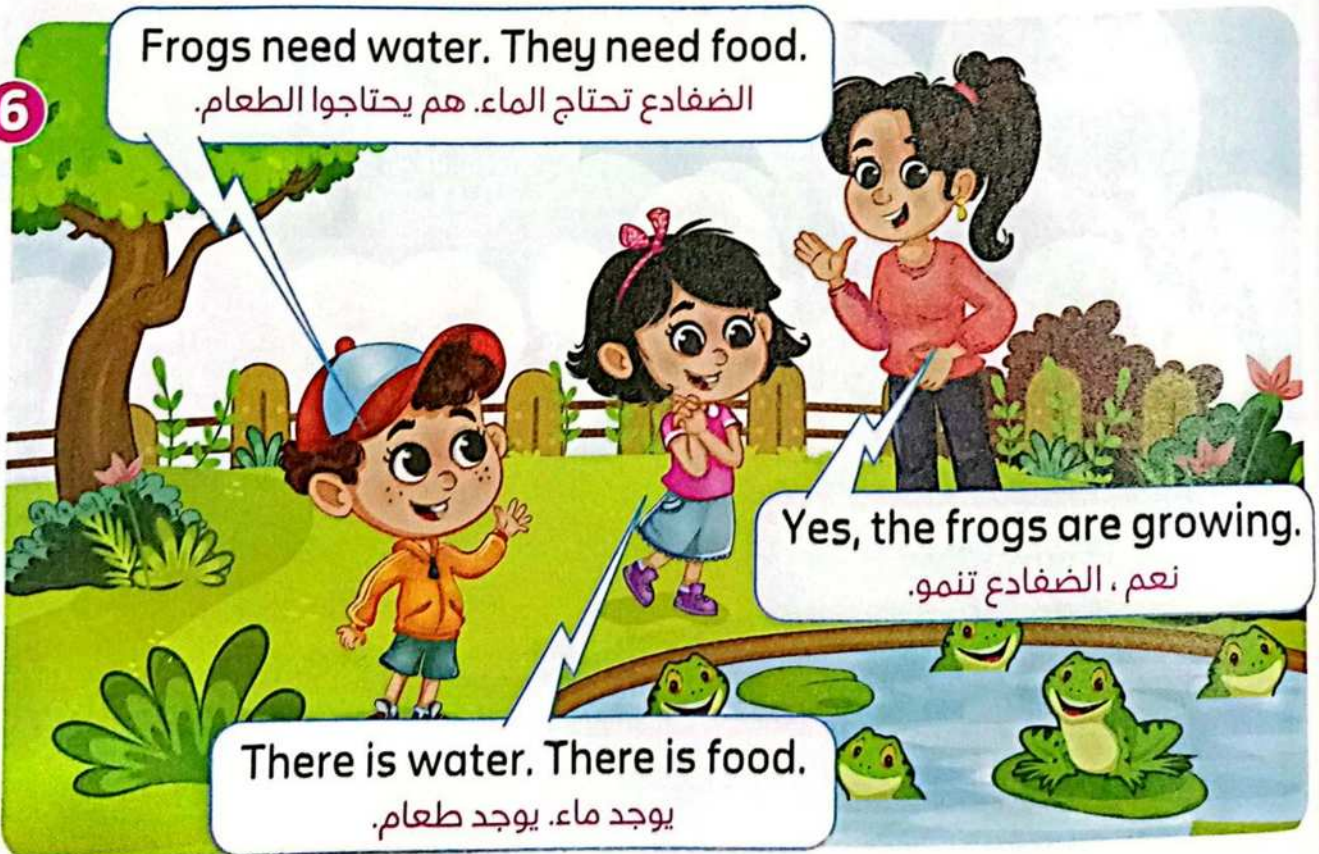

Frogs need water. They need food.

الضفادع تحتاج الماء. هم يحتاجوا الطعام.

Yes, the frogs are growing.

نعم ، الضفادع تنمو.

There is water. There is food.

يوجد ماء. يوجد طعام.

# Activities on lesson 13



## 1 Read and circle. اقرأ وضع دائرة.

1. baby frog



2. food



3. grow



## 2 Listen and tick [✓]. استمع وضع علامة (✓).

1.



adult frog

baby frog

2.



food

water

## 3 Look and circle [✓] or [X]. انظر وضع دائرة حول علامة (✓) او (X).

1.



animals

✓ / X

2.



food

✓ / X

3.



panda

✓ / X

4 Color and write. لون واكتب.

1.

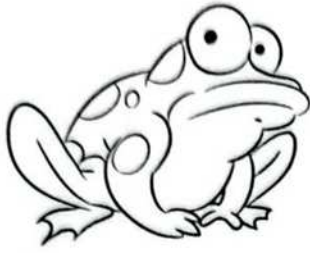

\_\_\_\_\_

-----

\_\_\_\_\_

2.

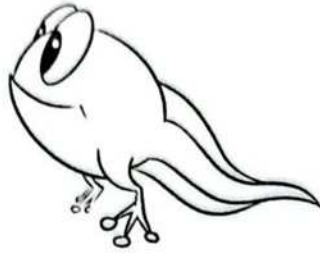

\_\_\_\_\_

-----

\_\_\_\_\_

3.

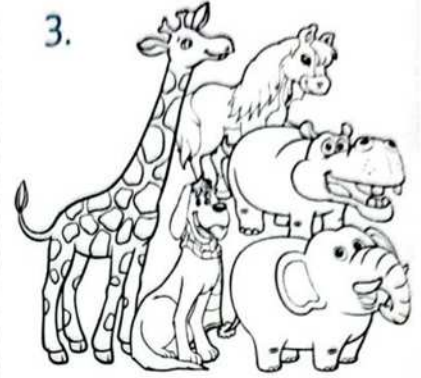

\_\_\_\_\_

-----

\_\_\_\_\_

5 Listen and circle. استمع وضع دائرة.

1.

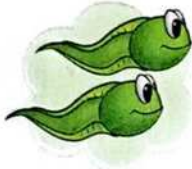

Baby frogs grow / don't grow.

2.



A frog is a living / non-living thing.

3.

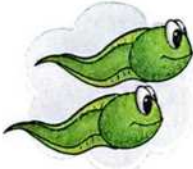

A baby frog needs animals / food.

4.



Animals are living / non-living things.

6 Copy the following. انسخ الآتي.

• We look after animals.

\_\_\_\_\_

-----

\_\_\_\_\_

# Review on UNIT 3



sheep



rabbit



cat



fish



horse



panda



frog



camel



red

Rr

/r/



run



rabbit



sharpener



Reem

Pp

/p/



pan



panda



Peter



Pyramids

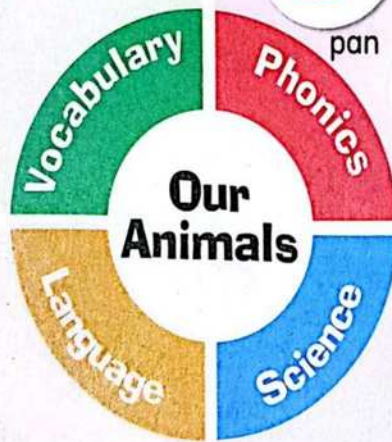

Camels live on land.



Fish live in water.

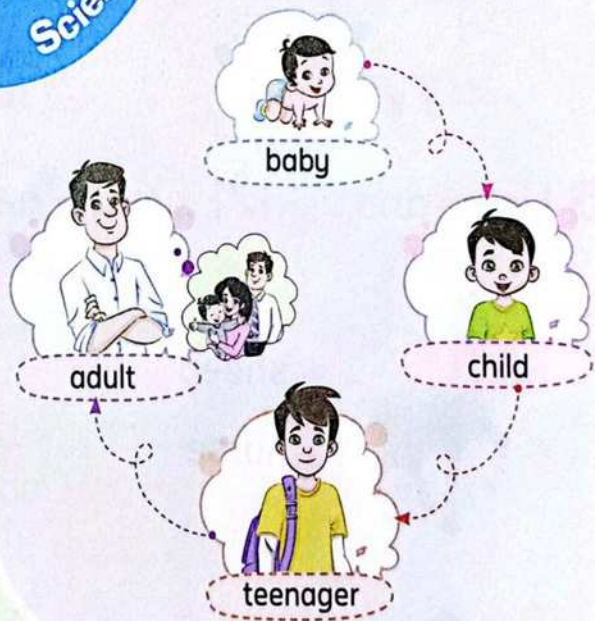

• Help your child review Unit 3.

- ساعد طفلك في مراجعة الوحدة الثالثة.

# Activities on Unit 3

1 Listen and circle. استمع وضع دائرة.

1. horse



2. sheep



2 Listen and match. استمع وصل.

sheep

horse

adult



3 Listen and tick [✓]. استمع وضع علامة (✓).

1.



sheep

horse

2.



living thing

non-living thing

3.



child

adult

4.



frog

cat

4 Look, unscramble and write. انظر، اعد ترتيب الحروف واكتب.

1.



b r a b i t

\_\_\_\_\_

-----

\_\_\_\_\_

2.



s h f i

\_\_\_\_\_

-----

\_\_\_\_\_

3.



e r o h s

\_\_\_\_\_

-----

\_\_\_\_\_

5 Trace and Color. تتبع ولون.

1.

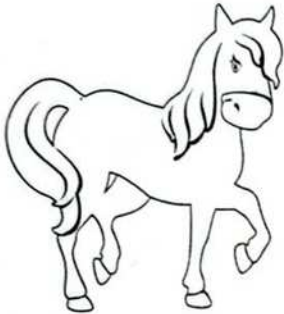

horse

2.



rabbit

3.

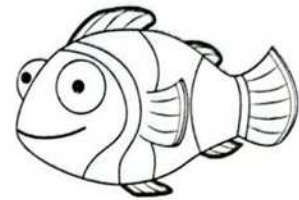

fish

6 Look, read and circle. انظر، اقرأ وضع دائرة.

1.



sharpener  
pen

2.



fish  
panda

3.



frog  
camel

7 Copy the following. انسخ الآتي.

• Camels live on land.

\_\_\_\_\_

-----

\_\_\_\_\_

4

UNIT FOUR

Our world

عالمنا





# Unit 4 Objectives

By the end of the unit, your child will be able...

بنهاية هذه الوحدة، سيكون طفلك قادر على ...

## Lessons 1 & 2

• **Objectives** : To identify salad and vegetables

- أن يتعرف على السلطات والخضروات

• **Vocabulary** : tomato, carrot, corn, cucumber, lettuce, salad

- ثمرة طماطم، جزرة، ذرة، خيار، خس، سلطة

## Lesson 3

• **Objectives** : To be able to differentiate between food that is healthy or unhealthy for us

- أن يكون قادراً على أن يفرق بين الطعام الصحي أو غير الصحي لنا

• **Vocabulary** : sweets, cola, chocolate

- حلوى، كولا، شيكولاته

• **Language** : It's healthy/unhealthy.

- إنه صحي / غير صحي.

## Lesson 4

• **Objectives** : 1. To learn about sensible hand hygiene in different situations, including before eating

- 1 أن يتعلم عن نظافة اليد الصحية في مواقف مختلفة بما في ذلك قبل الأكل

2. To have a basic idea of the concepts of before and after

- 2 أن يكون لديه فكرة أساسية عن مصطلح قبل وبعد

• **Vocabulary** : hands, wash, bathroom, before, after

- أيدي، يغسل، حمام، قبل، بعد

• **Language** : Let's wash our hands.

- هيا نغسل أيدينا.

## Lessons 5 & 6

• **Objectives** : To have a basic understanding of the weather

- أن يكون لديه معرفة أساسية بالطقس

• **Vocabulary** : cloud, rain, puddle, sun

- سحابة، مطر، بركة ماء، شمس

## Lesson 7

• **Objectives** : To talk about our environment and environmental responsibility

- أن يتحدث عن بيئتنا والمسئولية البيئية

• **Vocabulary** : living, non-living

- حي، غير حي

## Lesson 8

• **Objectives** : To use critical thinking skills to sort items into categories based on their type

- أن يستخدم مهارات التفكير النقدي ليصنف الأشياء لمجموعات طبقاً لنوعهم

• **Vocabulary** : red, green, yellow, cats, cows, cake, corn, apples

- لون احمر، اخضر، اصفر، قملط، ابقار، كيك، ذرة، تفاح

## Lessons 9 & 10

• **Objectives** : To say and write D/d, S/s in speech and writing

- أن يقول ويكتب حرفي S/s, D/d في الكلام والكتابة

• **Vocabulary** : Daddy, duck, Dina, dog, sun, Seleem, salad, sister, sad, Sara, dig, Sami

- أب، بطه، دينا، كلب، شمس، سليم، سلطة، أخت، حزين، سارة، يحضر، سامي

## Lesson 11

• **Objectives** : To be able to talk about animals, vegetables and their colors

- أن يكون قادراً على التحدث عن الحيوانات، الخضروات والوانها

• **Vocabulary** : colors, numbers to 10, duck, cat, carrot, tomato

- الوان، الارقام حتى رقم 10، بطه، قطعة، جزرة، طماطم

• **Language** : What color is it? It's a duck. It's brown.

- ما لونها؟ انها بطه، لونها بني.

## Lesson 12

• **Objectives** : To determine the difference between winter and summer

- أن يحدد الفرق بين الشتاء والصيف

• **Vocabulary** : winter, summer

- الشتاء، الصيف

• **Language** : I like...

- انا احب ...

## Lesson 13

• **Objectives** : To identify what we need to do before eating

- أن يحدد ما يجب أن نفعله قبل تناول الطعام

• **Issues** : Preventative health

- الصحة الوقائية



## Vocabulary

★ Listen and repeat. استمع وردد.



salad سلطة



corn ذرة



carrot جزرة

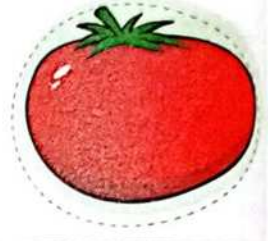

tomato ثمرة طماطم



cucumber ثمرة خيار



lettuce خس



## Activity

★ Trace and Color. تتبع ولون.

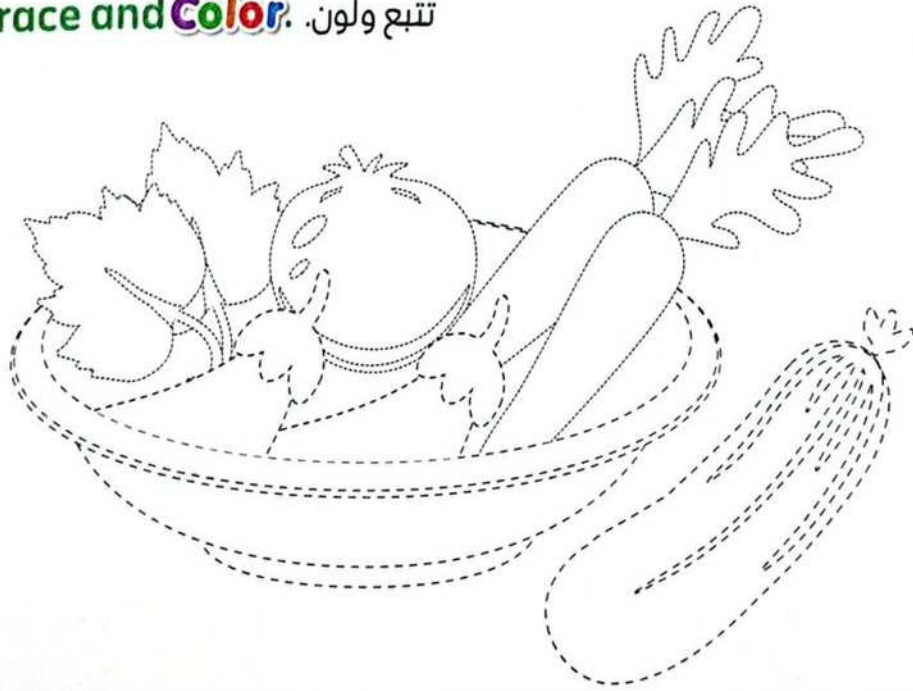

## Notes for parents

• Help your child trace the picture and color it.

• اطلبك ان يتتبع الصورة ويلونها.

★ Listen and look. استمع وأنظر.



What can you see?  
ماذا تستطيع ان تري؟



I can see a carrot.  
استطيع ان أري جزرة.



I can see corn.  
استطيع ان أري ذرة.



I can see salad.  
استطيع ان أري سلطة.

I can see a tomato.  
استطيع ان أري ثمرة طماطم.

I can see a cucumber.  
استطيع ان أري خياره.

I can see lettuce.  
استطيع ان أري خس.



• Help your child listen to the dialogue and let him/her look at the picture.

- ساعد طفلك ان يستمع إلى المحادثة وينظر إلى الصورة.



★ Listen, trace and write. استمع ،تتبع واكتب .

carrot



carrot

tomato



tomato

corn



corn

lettuce



lettuce

cucumber



cucumber

salad



salad

## Notes for parents

Unit 4

- Help your child to listen, trace the dotted words, then write it.

ساعد طفلك ان يستمع ، يتتبع الكلمات المكتوبة على شكل نقاط ثم يكتبها .

# Activities on lessons 1 & 2



1 Listen and circle. استمع وضع دائرة.

1. cucumber



2. corn



2 Listen and match. استمع وصل.

salad

lettuce

carrot

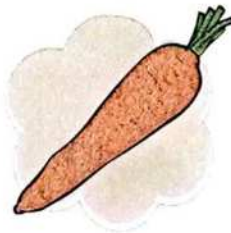

3 Listen and tick [✓]. استمع وضع علامة (✓).

1.



corn

tomato

2.



lettuce

salad

4 Look, unscramble and write. انظر، اعد ترتيب الحروف واكتب.

1.



o c r n

\_\_\_\_\_

-----

\_\_\_\_\_

2.



o o t t m a

\_\_\_\_\_

-----

\_\_\_\_\_

3.



a a s l d

\_\_\_\_\_

-----

\_\_\_\_\_

5 Color and write. لون واكتب.

1.



\_\_\_\_\_

-----

\_\_\_\_\_

2.

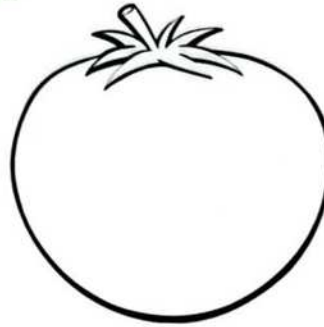

\_\_\_\_\_

-----

\_\_\_\_\_

3.



\_\_\_\_\_

-----

\_\_\_\_\_

6 Look and circle. انظر وضع دائرة.

1.



cucumber  
corn

2.



tomato  
lettuce

3.



carrot  
salad

## Vocabulary

☆ Listen and repeat. استمع وردد.

chocolate شيكولاتة

sweets حلوى

water ماء

cola  
كولا / مياه غازية



## Activity

☆ Color and number. لَوّن ورقم.

1. cola

2. sweets

3. chocolate



## Language

★ healthy food

الطعام الصحي

It's healthy. انه صحي.



★ unhealthy food

الطعام الغير صحي

It's unhealthy. انه غير صحي.



### Notes for parents

Unit 4

- Help your child differentiate between healthy and unhealthy food.

ساعد طفلك أن يفرق بين الطعام الصحي والطعام غير الصحي.



# Activities on lesson 3



1 Read and circle. اقرأ وضع دائرة.

1. tomato



2. cola



3. water



2 Listen and match. استمع وصل.

chocolate

sweets

water



3 Listen and tick [✓]. استمع وضع علامة (✓).

1.



It's healthy.

It's unhealthy.

2.



It's healthy.

It's unhealthy.

4 Look and circle (✓) or (X). انظر وضع دائرة حول علامة (✓) او (X).

1.



unhealthy

✓ / X

2.



cucumber

✓ / X

3.



tomato

✓ / X

5 Trace and Color. تتبع ولون.

1.

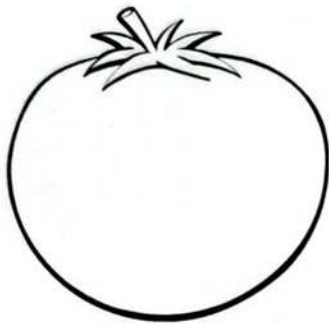

tomato

2.

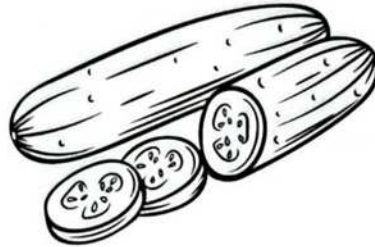

cucumber

3.

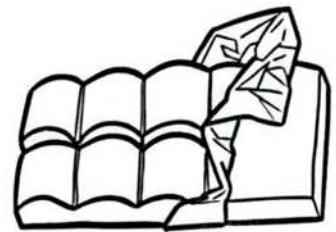

chocolate

6 Read and circle. اقرأ وضع دائرة.

1.

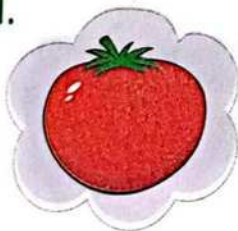

It's healthy ..  
unhealthy

2.



It's unhealthy ..  
healthy

3.

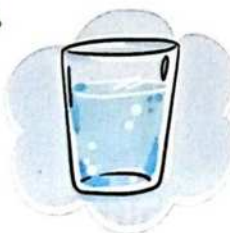

Water is healthy ..  
Cola

4.



It's unhealthy ..  
They're

## Vocabulary

★ Listen and repeat. استمع وردد.

wash يغسل

eat تأكل

hands أيدي

baby  
طفل رضيعuse  
يستخدمLet's wash  
our hands !

هيا بنا نغسل ايدينا!

animals  
حيواناتtouch  
تلمسbathroom  
حمام

cough يكح

# Language

★ Let's + inf. المصدر

هيا بنا.....



Let's wash our hands

before قبل



we eat. أن نأكل.



we touch a baby. أن نلمس طفل رضيع.

Let's wash our hands

after بعد



we use the bathroom. أن نستخدم دورة المياه.



we touch animals. أن نلمس الحيوانات.



we cough. أن نكح.

## Notes for parents

- Help your child know when he/she washes his/her hands.

أنت مفضلك ان يعرف متى يغسل يديه.

# Sing and do

Let's wash our hands,  
Before we eat,  
Before we eat,  
Before we eat.  
Let's wash our hands,  
Before we eat.  
Every day!



Let's wash our hands,  
After the bathroom,  
After the bathroom,  
After the bathroom.  
Let's wash our hands,  
After the bathroom.  
Every day!



• Sing with your child.

- غن مع طفلك.

انظر ولوّّن. ★ Look and Color. Activity



Let's wash our hands

بعد after



قبل before



Notes for parents

Unit 4

• Help your child to look at the pictures and color them.

ساعد طفلك في النظر إلى الصور ويلونها.

# Activities on lesson 4



1 Listen and circle. استمع وضع دائرة.

1. bathroom



2. baby



3. hands

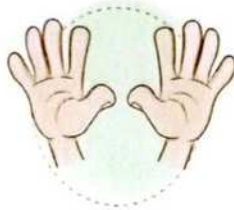

2 Listen and match. استمع وصل.

cough

wash

touch



3 Listen and tick (✓). استمع وضع علامة (✓).

1.



touch a baby

touch an animal

2.



animal

bathroom



## Vocabulary

☆ Listen and repeat. استمع وردد.

sun شمس



puddle بركة مياه

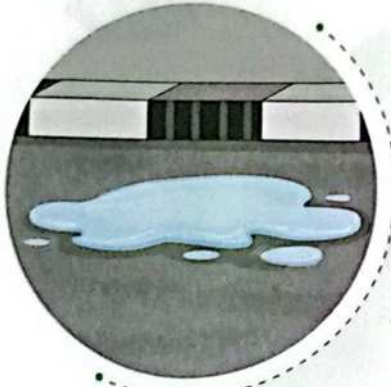

cloud سحابة



rain مطر / تمطر



sea بحر



# Speaking

Talking about the benefits of the sun and the rain.

التحدث عن فوائد الشمس والمطر.



 **Activity**  **Trace.** تتبع

The sun and rain are good for corn.

# Activities on lessons 5 & 6



1 Listen and circle. استمع وضع دائرة.

1. sea



2. cloud



3. rain



2 Listen and match. استمع وصل.

puddle

sea

rain



3 Listen and tick [✓]. استمع وضع علامة (✓).

1.



rain

puddle

2.



rain

cloud

4 Look and circle (✓) or (X). انظر وضع دائرة حول علامة (✓) او (X).

1.



sea

✓ / X

2.



puddle

✓ / X

3.



water

✓ / X

5 Color and write. لون واكتب.

1.

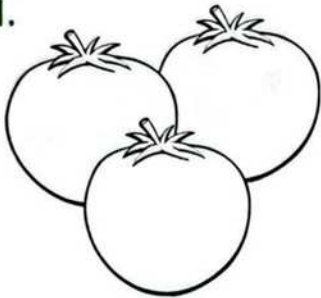

\_\_\_\_\_

-----

\_\_\_\_\_

2.



\_\_\_\_\_

-----

\_\_\_\_\_

3.

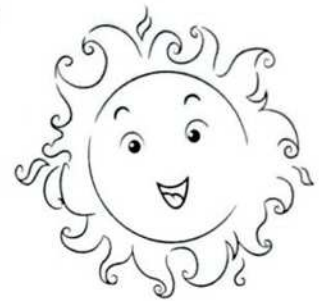

\_\_\_\_\_

-----

\_\_\_\_\_

6 Look and circle. انظر وضع دائرة.

1.



rain

sun

2.



puddle

water

3.



sea

cloud

7 Trace. تتبع.

The sun and rain are good for tomatoes.

★ Listen and look. استمع وانظر.

★ One - syllable words

كلمات ذات مقطع واحد



frog ضفدع



duck بطة



fish سمكة



★ Two - syllable words

كلمات ذات مقطعين

water ماء

wa ter



bottle زجاجة

bot tle



river نهر

riv er



Notes for parents

- Help your child to identify the words that consist of one syllable and two syllables.

ساعد طفلك أن يتعرف على الكلمات التي تتكون من مقطع واحد ومقطعين.

# Activities on lesson 7



1 Listen and match. استمع وصل.

1. river

2. water

3. frog

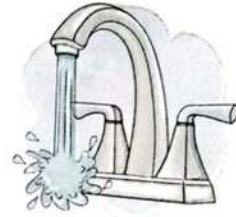

2 Listen and tick [✓]. استمع وضع علامة (✓).

1.



duck

bottle

2.

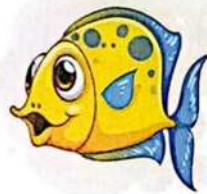

fish

frog

3 Trace and Color. تتبع ولون.

1.

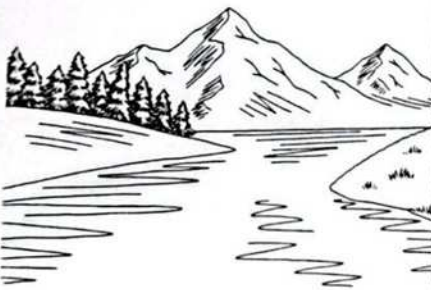

river

2.



bottle

3.

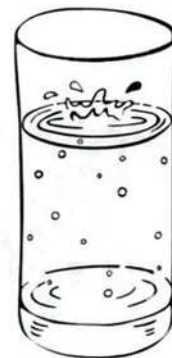

water



## Vocabulary

★ Listen and repeat. استمع وردد.

colors الألوان



red أحمر



yellow أصفر



green أخضر

food الطعام



cake كعكة

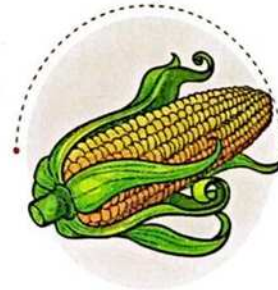

corn ذرة

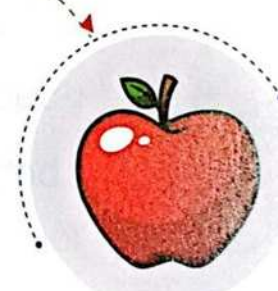

apple تفاحة

animals الحيوانات



COW بقرة



cat قطة

Notes for parents

- Help your child learn how to sort things.

ساعد طفلك ان يتعلم كيف يصنف الأشياء.

# Activity

★ Match each picture to the correct sorting.

صل كل صورة بالتصنيف الصحيح.



colors



animals



food



• Help your child to match each picture to its correct sorting.

- ساعد طفلك أن يصل كل صورة بالتصنيف الصحيح لها.

# Activities on lesson 8



1 Listen and circle. استمع وضع دائرة.

1. food



2. animals



2 Listen and match. استمع وصل.

1. food

2. colors

3. animals

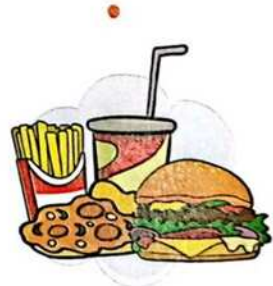

3 Listen and tick [✓]. استمع وضع علامة (✓).

1.

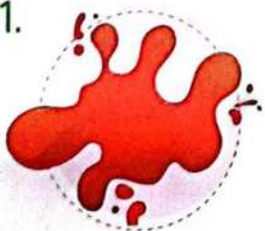

animal

color

2.



food

animal





Phonics

☆ Listen and repeat. استمع وردد.

daddy أب



duck بطء



Dina دينا



dog كلب



hand يد



D d

salad سلطة



sad حزين



sister أخت



S s



Sara سارة



sun شمس



Seleem سليم

• Help your child listen to the words that have the /d/ and /s/ sounds and repeat them.

- ساعد طفلك أن يستمع إلى الكلمات التي تحتوى على النطق الصوتى للصوتين /d/ و /s/ ويرددها.

★ Listen, trace and write. استمع، تتبع واكتب.

Dd

Dd

Dd

Dd



Dina

duck

daddy

hand

Ss

Ss

Ss

Ss



Seleem

sun

sister

salad

Notes for parents

- Ask your child to listen and identify the words that have /d/ and /s/ sounds and trace the dotted words and letters.

اطلب من طفلك ان يستمع ويتعرف على الكلمات التي بها الصوتين /d/ ، /s/ ، يتتبع الكلمات والحروف المكتوبة على شكل نقاط.

# Activities on lessons 9 & 10



1 Read and circle. اقرأ وضع دائرة.

1. Dina



2. dog



3. hand



2 Listen and match. استمع وصل.

duck

sun

Seleem



3 Read and tick [✓]. اقرأ وضع علامة (✓).

1.



duck

dog

2.



salad

sun

4. Look and circle (✓) or (X). انظر وضع دائرة حول علامة (✓) او (X).

1.



cloud

✓ / X

2.



duck

✓ / X

3.



daddy

✓ / X

5. Color and write. لون واكتب.

1.

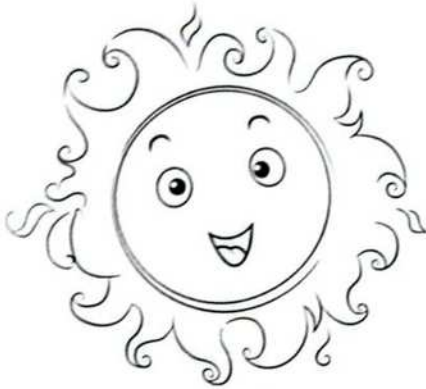

2.



3.

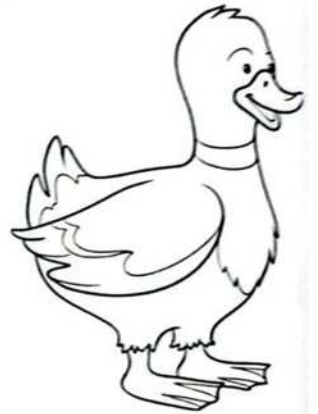

6. Circle and write. ضع دائرة واكتب.

1.



d  
b  
r

- uck

2.



t  
s  
h

- and

## Vocabulary

★ Listen and repeat. استمع وردد.

yellow أصفر

green أخضر

blue أزرق

brown بني

Colors



الألوان

red أحمر

orange برتقالي

gray رمادي

black أسود

white أبيض

# Activities on lesson 11



1 Listen and circle. استمع وضع دائرة.

1. red



2. yellow



2 Listen and match. استمع وصل.

gray

green

orange



3 Listen and tick [✓]. استمع وضع علامة (✓).

1.



green

blue



2.

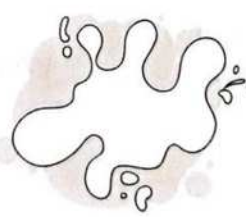

black

white

4 Look and circle (✓) or (X). انظر وضع دائرة حول علامة (✓) او (X).

1.



black

✓ / X

2.

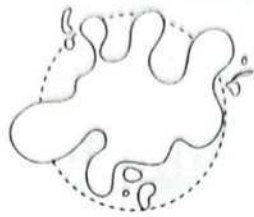

green

✓ / X

3.



yellow

✓ / X

5 Trace and Color. تتبع ولون.

1.

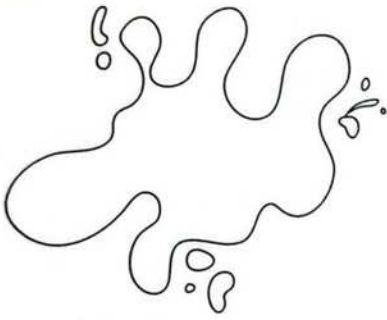

gray

2.

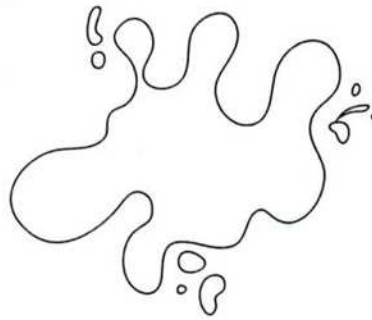

red

3.

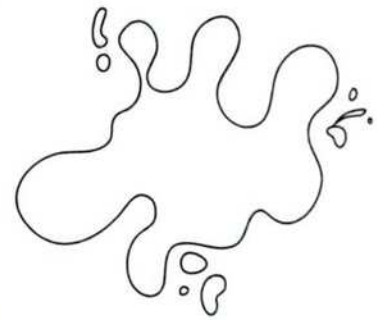

yellow

6 Look and circle. انظر وضع دائرة.

1.



red

blue

2.



black

brown

3.



green

white

## Language

★ Identifying seasons of the year. التعرف على فصول السنة.



It's winter.  
إنه فصل الشتاء.



It's summer.  
إنه فصل الصيف.

★ Expressing likes

التعبير عن ما تحبه.



I like winter.  
أنا أحب فصل الشتاء.



I like summer.  
أنا أحب فصل الصيف.

## Notes for parents

- Help your child to differentiate between winter and summer.
- Help your child to express what he/she likes.

ساعد طفلك أن يفرق بين فصل الشتاء وفصل الصيف.  
ساعد طفلك أن يعبر عما يحبه / تحبه.





# Activity

☆ Match and Color . صل ولون.

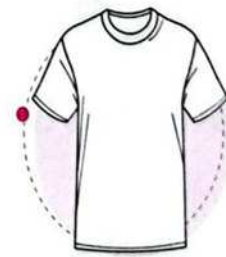
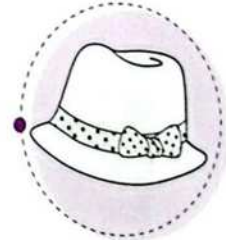
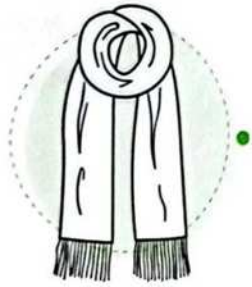

• Help your child match the clothes with their suitable season and color them.

- ساعد طفلك أن يصل الملابس بالفصل المناسب لها ويلونها.

# Activities on lesson 12



1 Listen and circle. استمع وضع دائرة.

1. summer



2. winter



3. sun



2 Listen and match. استمع وصل.

summer

winter

cloud



3 Listen and tick [✓]. استمع وضع علامة (✓).

1.



summer

winter

2.



sun

rain

4 Look and circle [✓] or [X]. انظر وضع دائرة حول (✓) او (X).

1.



winter

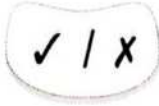

2.



summer



3.



sun



5 Listen and circle. استمع وضع دائرة.

1.



It's winter / summer

2.



I like winter / summer

3.



It's moon / sun

4.



It's It's a cloud.

6 Copy the following. انسخ الآتي.

• I like summer.

\_\_\_\_\_

\_\_\_\_\_

\_\_\_\_\_

Let's help !

هيا بنا نساعد !

Wash your hands before you eat !

اغسل يديك قبل أن تأكل !



# Let's help

★ Listen and look. استمع وانظر.

Let's help Mommy and Daddy.  
هيا بنا نساعد أمي وأبي.

1



Yes! نعم!

We have corn, carrots and lettuce.  
نحن لدينا ذرة، جزر وخس.

2

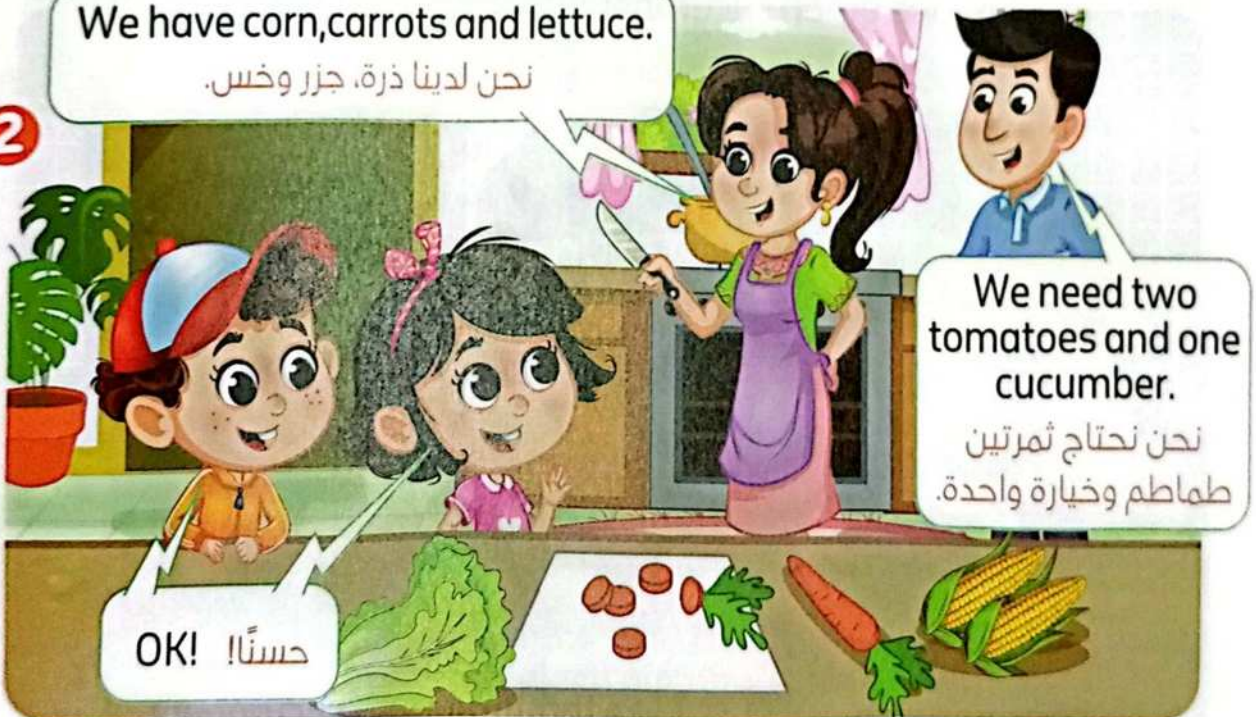

We need two  
tomatoes and one  
cucumber.

نحن نحتاج ثمرتين  
طماطم وخيارة واحدة.

OK! حسناً!

• Help your child listen to the scenes of the story and let him/her look at the pictures.

- ساعد طفلك في الاستماع إلى مشاهد القصة ودعه ينظر إلى الصور.

3

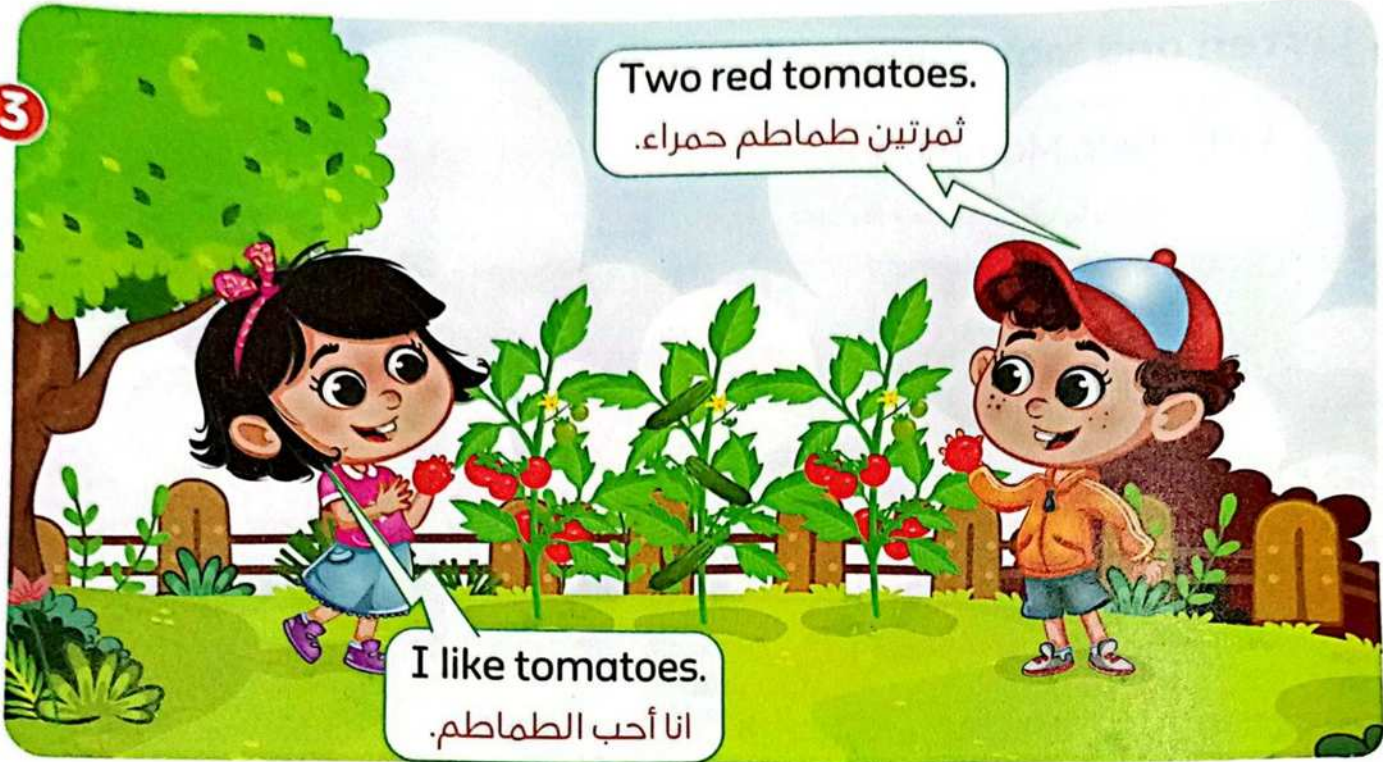

Two red tomatoes.

ثمرتين طماطم حمراء.

I like tomatoes.

انا أحب الطماطم.

4

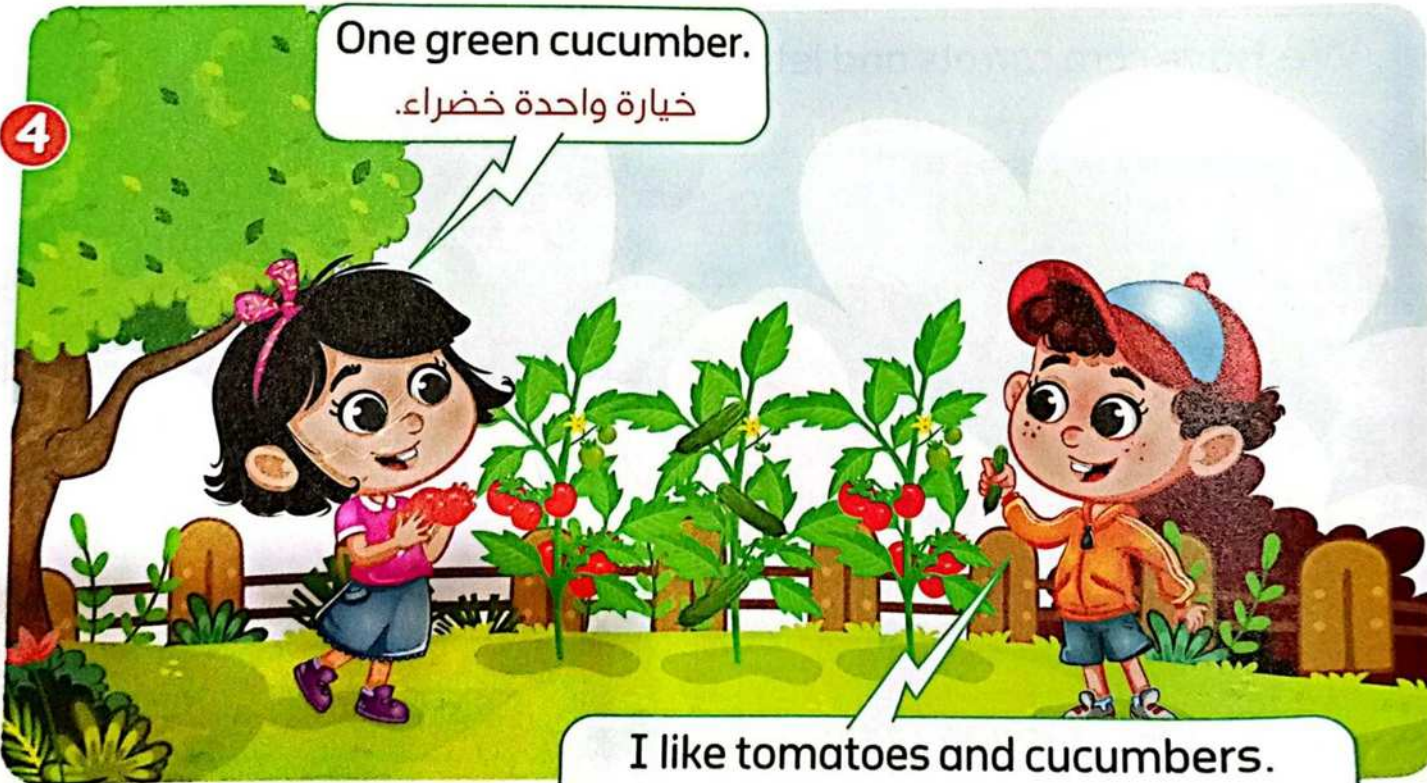

One green cucumber.

خيارة واحدة خضراء.

I like tomatoes and cucumbers.

انا أحب الطماطم و الخيار.

Adam, Dina, let's eat!

آدم، دينا، هيا بنا نأكل!

5

Mmm, salad!

ياه، إنها سلطة!

Adam, Dina, no!

آدم، دينا، لا!

Let's wash our hands.

هيا نغسل أيدينا.

6

Yes, let's wash our hands before we eat.

نعم، هيا نغسل أيدينا قبل الأكل.

# Activities on lesson 13



1 Listen and circle. استمع وضع دائرة.

1. corn

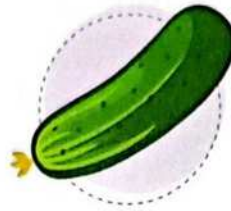

2. tomato



3. two cucumbers

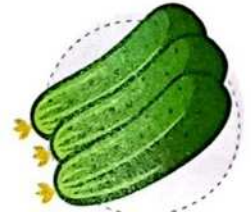

2 Listen and match. استمع وصل.

carrot

lettuce

cucumber

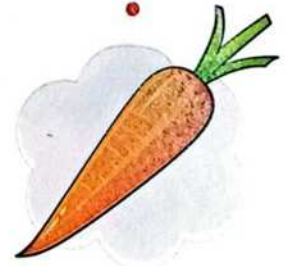
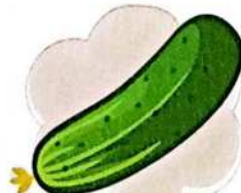

3 Listen and tick [✓]. استمع وضع علامة (✓).

1.



cucumber

corn

2.



tomato

carrot



4 Look and circle [✓] or [X]. انظر وضع دائرة حول علامة (✓) او (X).

1.



tomato

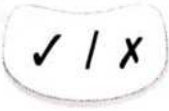

2.



lettuce

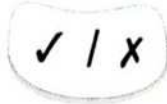

3.



cucumber



5 Circle and write. ضع دائرة واكتب.

1.

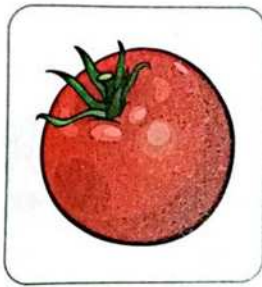

t  
d  
b

\_omato

2.

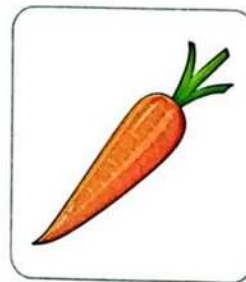

k  
c  
s

\_arrot

6 Listen and circle. استمع وضع دائرة.

1.



We need  $\frac{\text{two}}{\text{three}}$  tomatoes.

2.

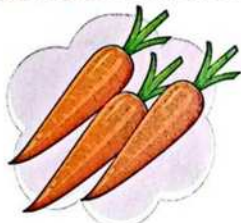

We have  $\frac{\text{cucumbers}}{\text{carrots}}$ .

3.

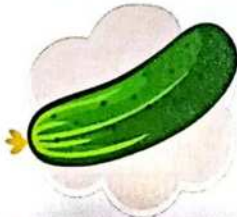

We need one green  $\frac{\text{carrot}}{\text{cucumber}}$ .

4.



We have  $\frac{\text{cucumber}}{\text{lettuce}}$ .

# Review on UNIT 4



carrot



tomato



lettuce



cucumber



corn



salad



rain



summer



duck



dog



sun



salad

**Dd**



daddy



Dina

**Ss**



sad



sister



It's healthy.

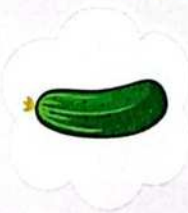

It's unhealthy.



Let's wash our hands before we eat.



Let's wash our hands after we use the bathroom.



1 Listen and circle. استمع وضع دائرة.

1. duck



2. summer



2 Listen and match. استمع وصل.

white

hand

salad

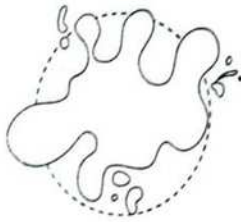

3 Listen and tick [✓]. استمع وضع علامة (✓).

1.



duck

horse

2.



cucumbers

carrots

4 Circle and write. ضع دائرة واكتب.

1.



t

m

-omato

2.



b

d

-uck

3.



s

c

-un

5 Look and circle (✓) or (X). انظر وضع دائرة حول علامة (✓) او (X).

1.



food

✓ / X

2.



water

✓ / X

3.



black

✓ / X

6 Trace and Color. تتبع ولون.

1.



winter

2.

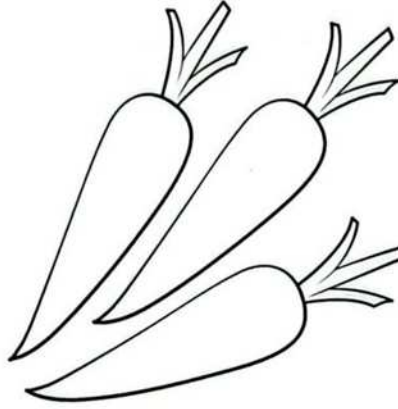

carrots

3.



summer

7 Look and circle. انظر وضع دائرة.

1.

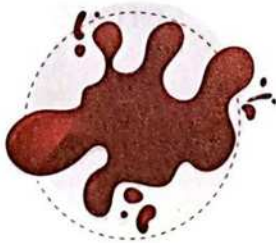

black

brown

2.



winter

summer

3.



river

sea

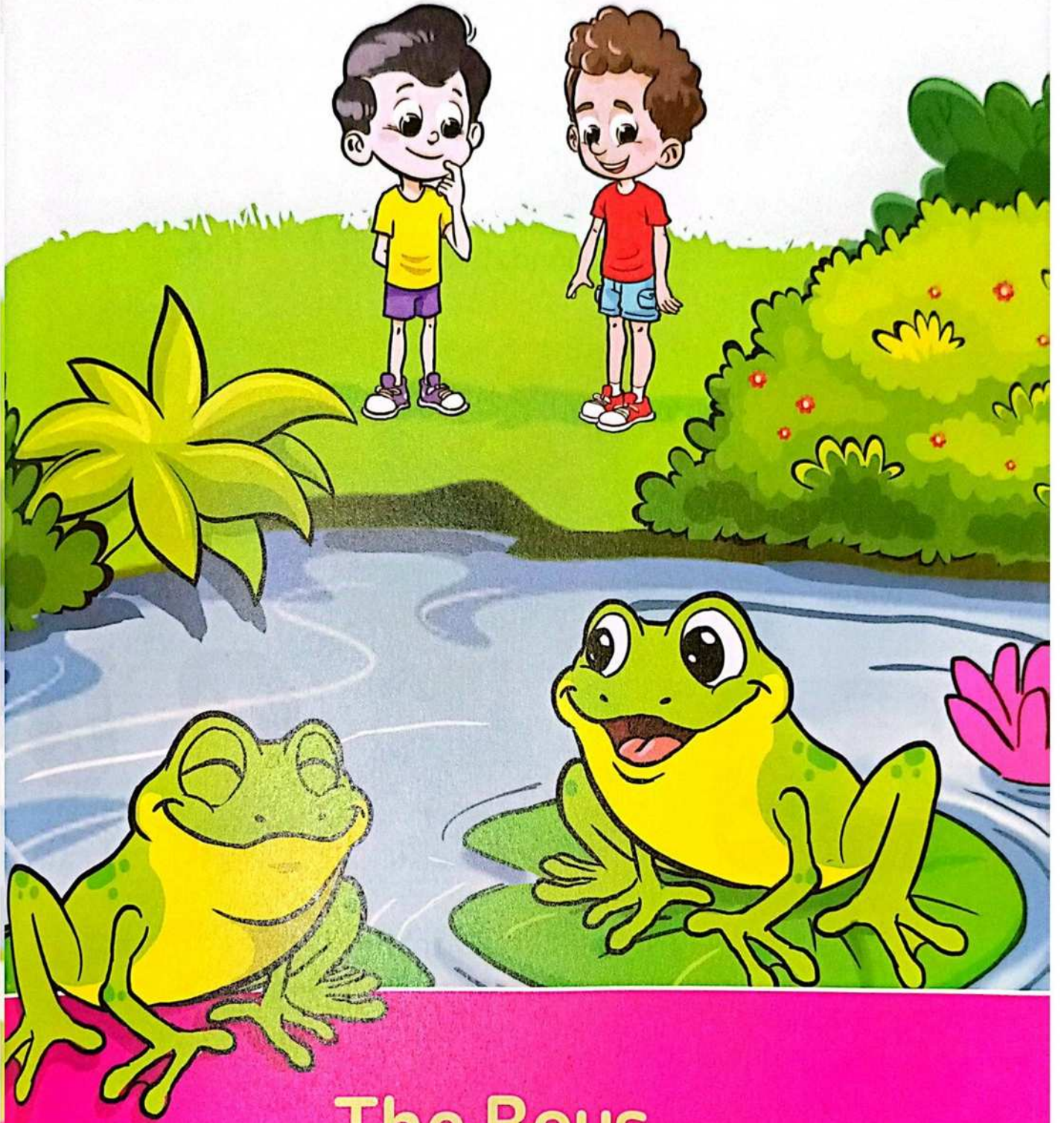

# The Boys and the Frogs

الأولاد و الضفادع

By Nicola Gardner

# Picture Dictionary

القاموس المصور



play يلعب



pond بركة ماء



frogs ضفادع



water ماء



happy سعيد



flowers زهور



sad حزين



hurt يؤلم / يجرح



boys أولاد



The main idea of the story is about

الفكرة الرئيسية لهذه القصة عن

- How we can care for animals and nature.

كيف نستطيع الاهتمام بالحيوانات و الطبيعة.



# Story Map

خريطة القصة

**Who?**

The main characters

الشخصيات الرئيسية



Seleem



Mazen

**Who?**

The supporting characters

الشخصيات المساعدة



frogs

**Where? The setting** المكان



pond ماء بركة

**Story**



**Beginning**

بداية القصة

Seleem and Mazen are playing.



**Middle**

منتصف القصة

They can see water and flowers.



**End**

نهاية القصة

The boys and the frogs are friends.



This is Seleem. This is Mazen. - هذا سليم. هذا مازن.



Let's play! - هيا بنا نلعب!

This is ..... هذا ..... play يلعب





Look! It's a pond! - انظر! إنها بركة ماء!



I can see water. I can see flowers.  
أنا أستطيع أن أرى ماء. أنا أستطيع أن أرى زهور.

look ينظر pond بركة ماء see يري flowers زهور water ماء



happy

سعيد frogs

ضفادع like

يحب



This is fun! - هذا ممتع!



We are sad frogs. - نحن ضفادع حزينة.

fun ممتع sad حزين



game

لعبه

stop

يتوقف



My friend is hurt!

- لقد جُرح صديقي!



Sorry, frogs!

- آسف، أيتها الضفادع!

hurt

يجرح/ يؤلم

Sorry!

آسفا!





1 Read and circle. اقرأ وضع دائرة.

1

The frogs like the  
pond / park.

2

Seleem and Mazen are  
brothers / friends.



2 Listen and match. استمع وصل.

1. Let's play!



2. We are happy frogs.

3. We are sad frogs.



4. They're see flowers.

1. Help your child to read the sentences and circle the correct answer according to the story.

- ساعد طفلك أن يقرأ الجمل ويضع دائرة حول الإجابة الصحيحة طبقاً للقصة.

2. Ask your child to listen to each sentence and match it to its suitable picture.

- اطلب من طفلك أن يستمع إلى الجمل ويصلها بالصورة المناسبة لها.

# General Revision

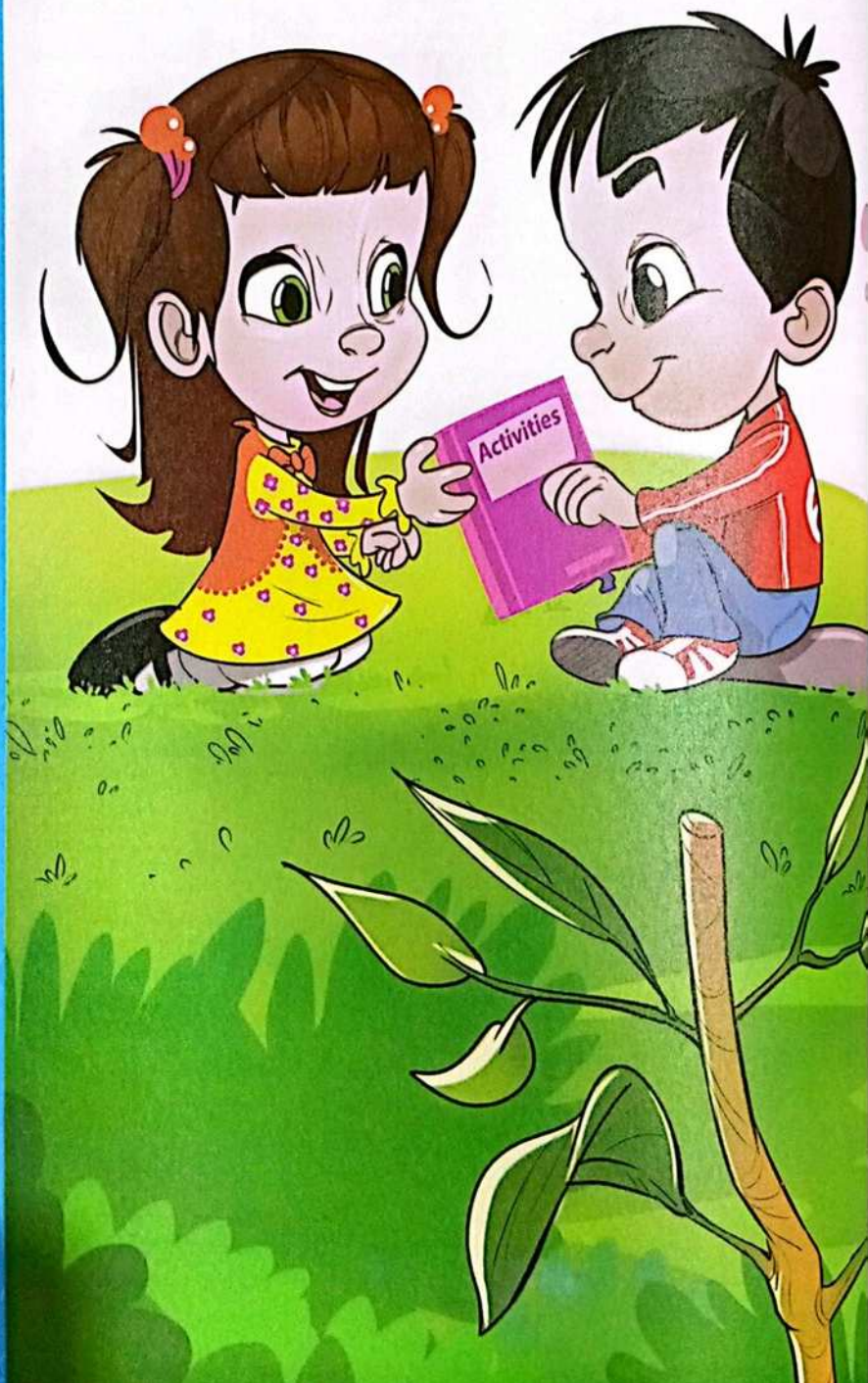
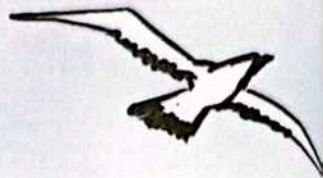



# Review on UNITS 1, 2, 3 & 4



brother



sister



daddy



pencil



eraser



sharpener



mommy



ear



eye



chair



table



board



nose



mouth



square



triangle

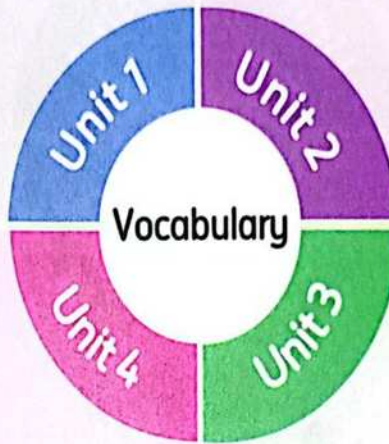

tomato



carrot



frog



sheep



corn



yellow



gray



fish



cat



grow



black



sea



cloud



breathe



land



water

• Help your child review the vocabulary of the units.

- ساعد طفلك في مراجعة المفردات اللغوية الخاصة بالوحدات.

**Bb**



Bye!



blue



brown

**Mm**



Maha



classroom



mouth

**Hh**



Hello!



hand

**Nn**



Nour



nurse



hair



pen

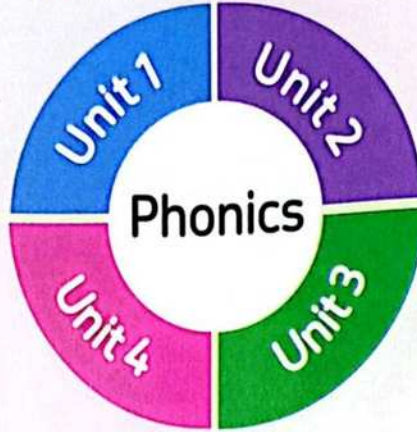

**Dd**



Dina



duck



dog

**Pp**



Pyramids



panda



Pan

**Ss**



sun



sad

**Rr**



rabbit



red



salad



run

**Notes for parents**

- Help your child review the phonics of the units.

ساعد طفلك في مراجعة الصوتيات الخاصة بالوحدات.

# Activity 1



1 Listen and circle.

استمع وضع دائرة.

1. brother



2. frog



3. sea



2 Listen and match.

استمع وصل.

1.

black

2.

mouth

3.

chair



3 Listen and tick [✓].

استمع وضع علامة (✓).

1.



2.



3.



ear

table

daddy

eye

chair

mommy

4 Circle and write.

1.

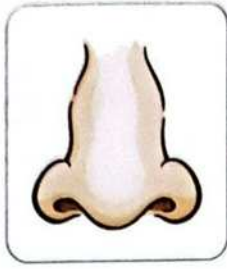

m  
n

- ose

2.



s  
d

- alad

3.



h  
b

- ee

5 Look, read and write.

eat - healthy - round - legs

1.



It's .....

2.



Living things .....

3.



Touch your .....

4.



A circle is .....

6 Trace.

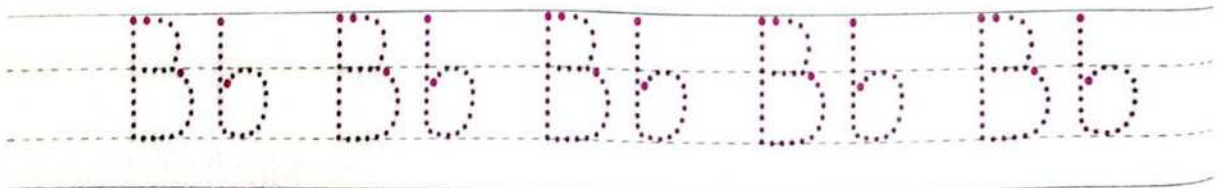

# Activity 2



1 Listen and circle.

استمع وضع دائرة.

1. carrot



2. nose



3. sheep



2 Read and match.

اقرأ وصل.

1. cloud

2. sister

3. triangle

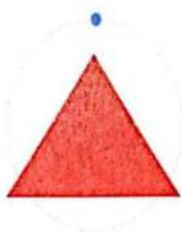

3 Listen and tick (✓).

استمع وضع علامة (✓).

1.



2.



3.



cat

square

pen

frog

circle

pencil

4 Listen and circle (✓) or (X).

الاستماع وضع دائرة حول علامة (✓) او (X).

1.



cat

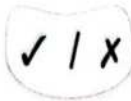

2.



healthy

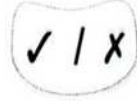

3.



sad

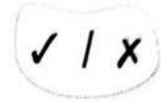

5 Look, read and write.

نظر، اقرأ وأكتب.

blue - summer - land - mouth

1.



Camels live on .....

2.



This is my .....

3.



I like .....

4.



I have ..... eyes.

6 Trace.

تتبع

This is my balloon.

# Activity 3



Listen and circle.

استمع وضع دائرة.

1. camel



2. circle

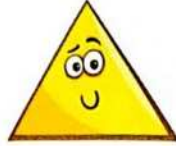

3. leg



Listen and match.

استمع وصل.

1. summer

2.

help

3.

eat



Listen and tick [✓].

استمع وضع علامة (✓).



2.



3.



eraser

nurse

hair

pencil

teacher

arm

4 Circle and write.

1.

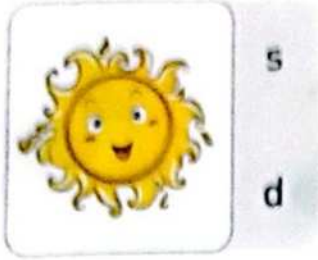

- un

2.

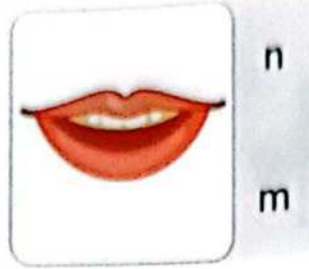

- outh

3.

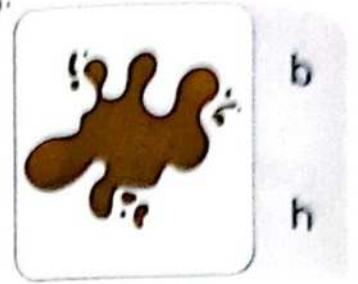

- rown

5 Look, read and write.

unhealthy - eraser - cat - hands

1.



This is an .....

2.



My favorite animal is the .....

3.



Let's wash our .....

4.



It's .....

6 Trace.

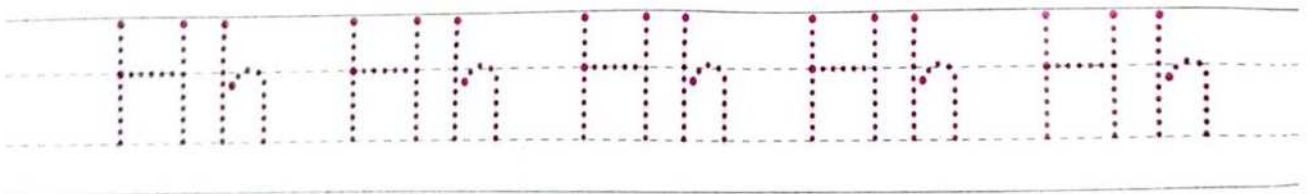



# Activity 4



1 Listen and circle.

استمع وضع دائرة.

1. chair

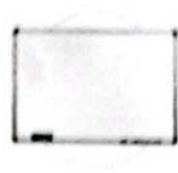

2. sister



3. corn

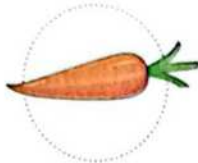

2 Listen and match.

استمع وصل.

1. yellow

2. cat

3. land



3 Listen and tick [✓].

استمع وضع علامة (✓).

1.



2.



3.



red

board

hand

black

table

foot

4 Listen and circle (✓) or (X).

استمع وضع دائرة حول علامة (✓) او (X).

1.



yellow

✓ / X

2.

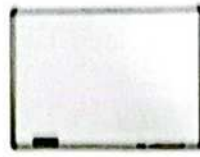

board

✓ / X

3.



living thing

✓ / X

5 Look, listen and write.

انظر، استمع وأكتب.

mommy - ears - water - teacher

1.



I have two .....

2.



This is my .....

3.



My ..... helps me write.

4.



Fish live in .....

6 Trace.

تتبع.

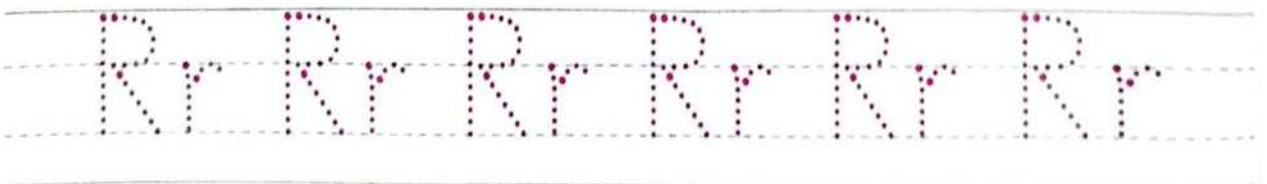

# Activity 5



Listen and circle.

استمع وضع دائرة.

1. baby



2. librarian



3. classroom



Listen and match.

استمع وصل.

1. arm

2. bee

3. pen



Listen and tick [✓].

استمع وضع علامة (✓).

1.



2.



3.



green

one

hand

blue

two

hair

ضع دائرة وأكتب.

4 Circle and write.

1.

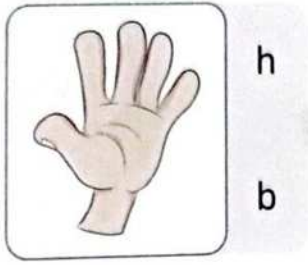

-and

2.

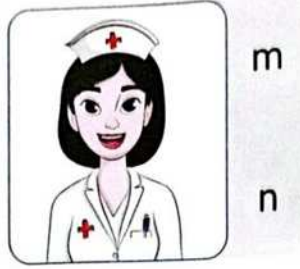

-urse

3.

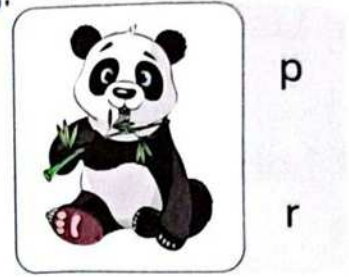

-anda

5 Look, read and write.

انظر، اقرأ وأكتب.

grow - pens - yellow - nose

1.



There are three .....

2.



Non-living things don't .....

3.



It's .....

4.

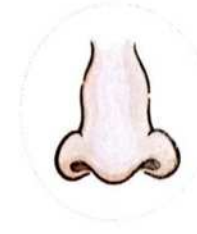

This is my .....

6 Trace.

تتبع.

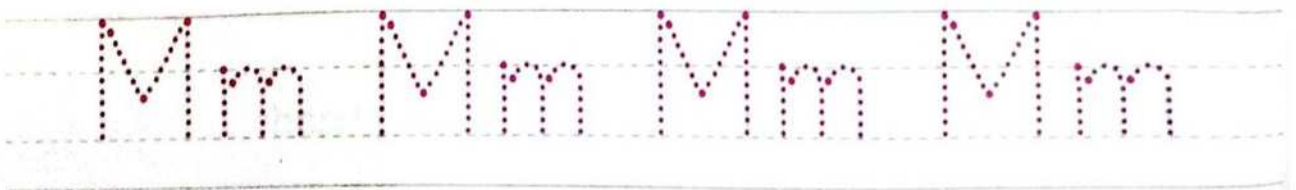

# Game cards

كروت للعب داخل كتاب الشرح وهديّة المعاصر لعبة MOKIDS

## Unit 1 cards



## Unit 2 cards

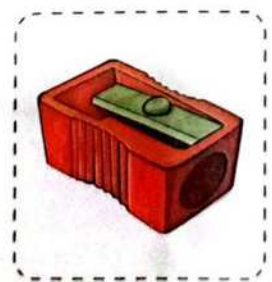
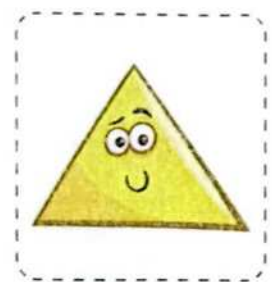

## Unit 3 cards

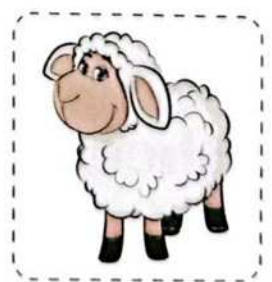
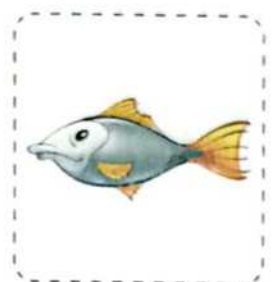

## Unit 4 cards

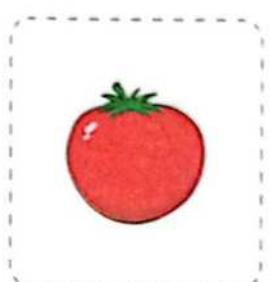
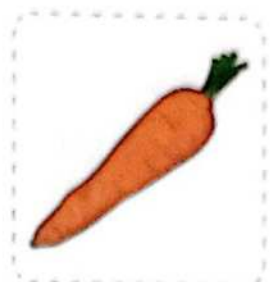

## Game cards

كروت للعب داخل كتاب الشرح وهدية المعاصر لعبة MOKIDS

Unit 4

cards

carrot

cucumber

tomato

sun

lettuce

cow

Unit 3

cards

camel

horse

fish

pan

baby

sheep

Unit 2

cards

table

pencil

nurse

triangle

teacher

sharpener

Unit 1

cards

brother

nose

arm

bag

bee

mouth



# Letters cards

A

B

C

D

E

F

G

H

I

J

K

L

M

N

O

P

Q

R

S

T

U

V

W

X

Y

Z

a

b

c

d

e

f

g

h

i

j

k

l

m

n

o

p

q

r

s

t

u

v

w

x

y

z

نصرف مجاناً مع الكتاب  
أقلعة للتمثيل

FREE GIFT  
NOT FOR SALE

أدخل كودك الشخصي  
الموجود على ظهر الغلاف



EL-MOASSER

Parents' Guide

NOW

at all bookstores...

EL-MOASSER IN: Connect Plus, Math & Discover

is an ideal supplement to Connect KG 1 Plus. It aims at guiding parents how to enhance their children's English language skills and knowledge through detailed and clear instructions. It has supporting activities which have been developed carefully to fulfill Connect KG 1 Plus objectives based on Content and Language Integrated Learning (CLIL).



GPS



AL TALABA BOOKSTORE

For printing, publication & distribution

El Faggala - Cairo - Egypt

Tel.: 02/ 259 340 12 - 259 377 91

E-mail: info@elmoasserbooks.com

www.elmoasserbooks.com

15014

الآن بالمكتبات...

المعاصر في...

اللغة الإنجليزية

kg1 من Connect Plus

إلى الصف السادس الابتدائي

بتصريح وتحت إشراف

وزارة التربية والتعليم



CONNECT Plus



KG1  
FIRST TERM

f /ElMoasserreg