

CONNECT

Plus

By a group of supervisors

Parents' Guide

دليل ولي الأمر



معاك
Ma3ak App

تطبيق
التعلم التفاعلي



بتصريح وتحت إشراف
وزارة التعليم والتقني

MINISTRY OF EDUCATION AND TECHNICAL EDUCATION



الصف الأول التمهيدي
رياض الأطفال
للمدارس الرسمية والخاصة لغات
الفصل الدراسي الأول

2023

KG1

FIRST TERM



GUIDE

CONNECT

Plus

By a group of supervisors

الصف الأول التمهيدي لغات
رياض اطفال للمدارس الرسمية و الخاصة لغات



Parents' Guide
دليل ولي الأمر



AL TALABA BOOKSTORE

For printing, publication & distribution

El Faggala - Cairo - Egypt

Tel.: 02/ 259 340 12 - 259 377 91

E-mail: info@elmoasserbooks.com

www.elmoasserbooks.com

☎ 15014

KG1

2023

All rights reserved

بِسْمِ اللَّهِ الرَّحْمَنِ الرَّحِيمِ

﴿إِنَّ الَّذِينَ آمَنُوا وَعَمِلُوا الصَّالِحَاتِ إِنَّا لَا نُضِيعُ أَجْرَ مَنْ أَحْسَنَ عَمَلًا﴾
صَدَقَ اللَّهُ الْعَظِيمُ

Egyptian National Library
Cataloging During Publishing
Prepared by Technical Affairs Department

El Moasser Guide based on Connect plus for
Nursery Schools

By a Group of Supervisors

Cairo : G.P.S for Printing, Publishing
& Distribution, 2022 - 2023

P. ; cm.

For KG 1 - First Term

I.S.B.N : 978 - 977 - 475 - 872 - 3

English language - study and teaching.

I Series

372.218

رقم الإيداع : ٩٦٠٣ / ٢٠٢٢

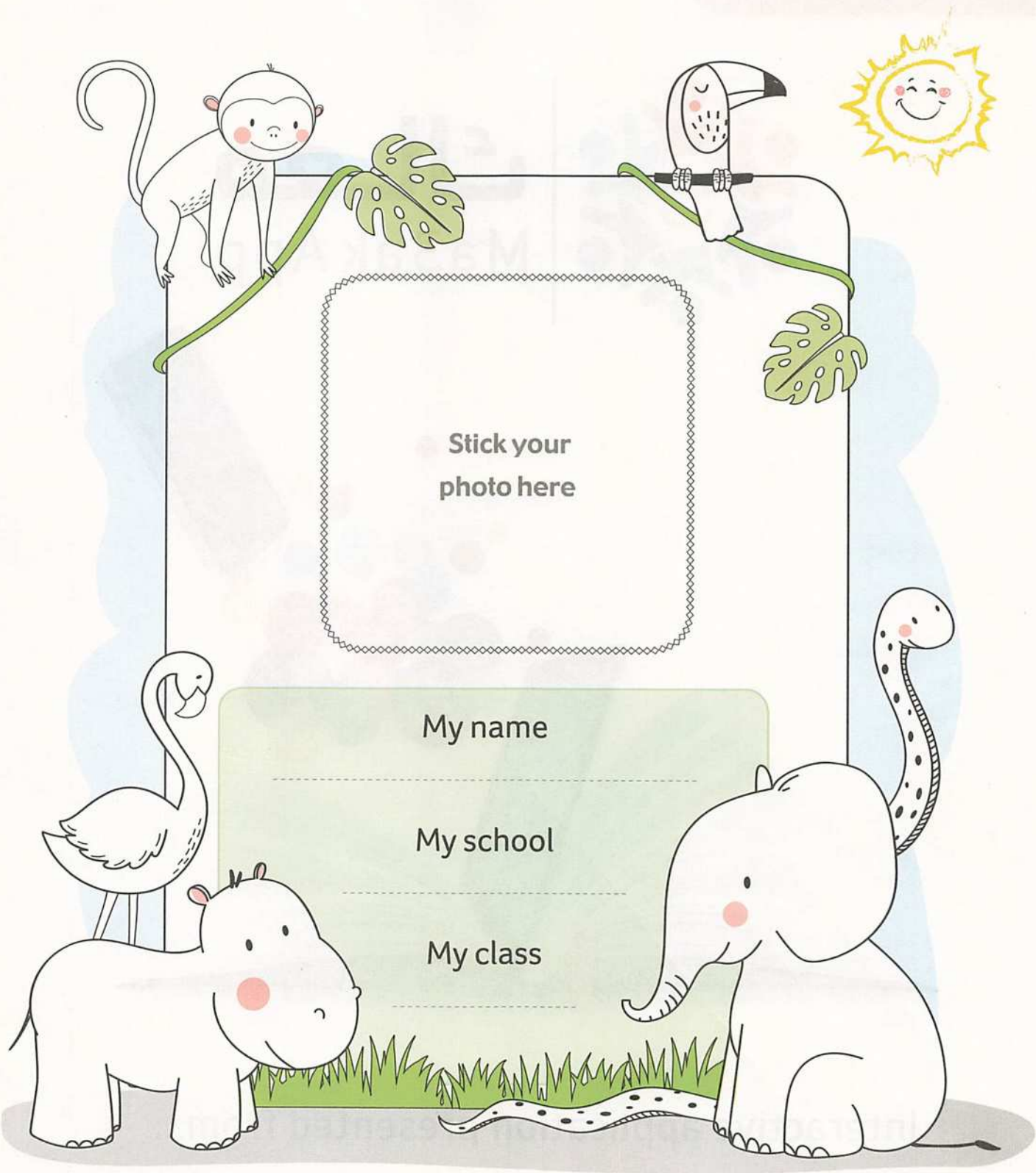

Stick your photo here

My name

My school

My class

NEW



معاك
Ma3ak App

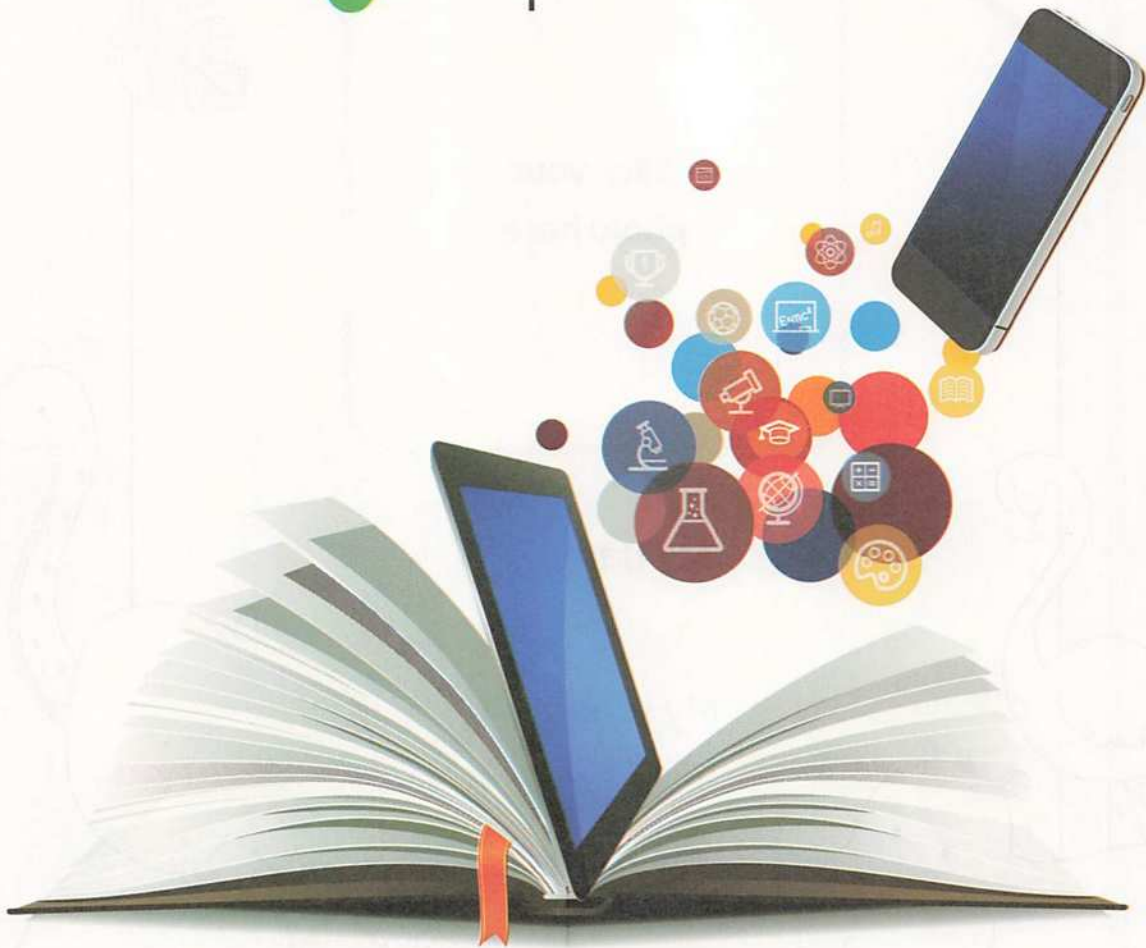

Interactive application presented from...



EL-MOASSER

How to use the application ?

1

Download the app



2

Create an account

Student account ✓

Parents account ✓

Teacher account ✓

3

Use the book code

You can find the code on the back cover of the book.



Enjoy

Interactive learning on all subjects and get all the app features free.



Parents' Guide

دليل أولياء الأمور

المحتويات :

١ مقدمة الدليل.

٢ هدف الدليل.

٣ فلسفة الدليل.

٤ موضوعات الدليل.

Our goal is fostering child's learning and thinking skills.
هدفنا طفل يتعلم وينمي مهاراته العقلية والسلوكية.



١ مقدمة الدليل

- * **This Parents' Guide** is carefully designed to develop the child's language skills (listening, speaking, reading, and writing) through fun activities, songs and simple mini-dialogues.
- * It aims to provide KG 1 plus students with the tools they need to develop their knowledge and practise the English language through understanding themselves and the environment around them.

* هذا الدليل : صُمم بعناية ودقة لتنمية مهارات الطفل اللغوية (الاستماع، التحدث، القراءة والكتابة) من خلال أنشطة مرحية، أغان ومحادثات صغيرة مبسطة.
* يهدف إلى إمداد تلاميذ الصف الاول التمهيدي لغات بالأدوات التي يحتاجونها لتطوير معرفتهم وممارسة اللغة الإنجليزية من خلال فهمهم لأنفسهم والبيئة المحيطة بهم. **ليس بديلاً** عن الكتاب المدرسي ولكنه مصاحب له.

٢ هدف الدليل

- * **This Parents' Guide** includes values : such as honesty, cooperation, politeness, respect and independence within different activities, photos and songs.
- * **This Parents' Guide** developed life skills, such as sharing, communication, creativity, critical thinking, problem solving through different activities and projects.

* **هذا الدليل :**
• يحتوى على بعض القيم، مثل : الصدق، التعاون، الأدب، الاحترام والاستقلالية عن طريق أنشطة و صور و أغان مختلفة.
• طوّر المهارات الحياتية مثل : المشاركة، التواصل، الإبداع، التفكير النقدي، حل المشكلات والعمل الثنائي والجماعي، من خلال أنشطة ومشروعات مختلفة.

- * Activities on vocabulary, language functions and phonics, including listening, speaking, reading, tracing, matching, coloring and writing tasks.
- * Activities on different life skills, values and issues, including listening, speaking, reading, acting as instructed and drawing tasks.
- * Activities on other curriculum parts, with a focus on math, science, art and social studies, including : counting, matching, drawing and collecting pictures tasks.
- * **The book is divided into two main themes :**
 - Who am I ?
 - The world around me.

* أنشطة على المفردات اللغوية، الوظائف اللغوية، الصوتيات، والتي تشمل : الاستماع، التحدث، القراءة، التتبع، التوصيل، التلوين ومهام الكتابة.

* أنشطة على المهارات الحياتية المختلفة، القيم والقضايا والتي تشمل : الاستماع، التحدث، القراءة، القيام بمهام فنية وتمثيلية موجهة.

* أنشطة على أجزاء من المناهج الدراسية الأخرى، مع التركيز على الرياضيات، العلوم، الرسم والدراسات الاجتماعية، تتضمن مهام العد، التوصيل، الرسم وتجميع الصور.

* **ينقسم الكتاب في هذا الفصل الدراسي إلى**

محورين أساسيين :

• من أكون ؟

• العالم من حولي.

- * This is me!
- * In my classroom
- * Our animals
- * Our world
- * The Boys and the Frogs

* هذا انا !

* في فصلي الدراسي

* حيواناتنا

* عالمنا

* الأولاد والضفادع

Guidebook دليل الكتاب



Lessons 1&2 Vocabulary

Vocabulary Listen and repeat. استمع وردد.

daddy أب
mommy أم
sister أخت
brother أخ

Notes for parents: Help your child listen to the words and repeat them.

٢ عرض شامل للدروس مبسط بالصور التوضيحية.

Prewriting worksheet

كيفية استخدام القلم الرصاص

How to use the pencil

١ كيف تتعامل مع منهج الصف الاول التمهيدي لغات.

Activities on Lessons 1&2

1 Listen and circle. استمع وضع دائرة.

1 daddy
2 brother
3. mommy

2 Listen and match. استمع وصل.

Adam sister daddy

3 Listen and tick (✓). استمع وضع علامة (✓).

1. mommy daddy
2. Dina Adam

Notes for parents: Help your child listen to the words and circle the correct picture. Ask your child to listen to the words and match them with the correct pictures. Ask your child to listen and tick for the correct word.

٤ أنشطة على الدروس.

Language

1 We use (This) when something or someone is close to us.

This is (my)

This is my mommy. هذا أمي.
This is my nose. هذا أنفي.

2 Introduce yourself.

Hello! I'm Heba. أهلاً أنا هبة.
Hello! I'm Mona. أهلاً أنا منى.

Notes for parents: Help your child to identify and express something / someone close to him / her using the demonstrative pronoun (This...). Help your child to introduce himself / herself using 'Hello!'.

٣ عرض للوظائف اللغوية بالصور التوضيحية.

Enjoy & learn

1 Listen and match. استمع وصل.

1 This is my balloon.

2 It's for daddy.

3 It's orange.

2 Look and color. انظر واولن.

red yellow blue

Notes for parents:

1. Ask your child to listen to the sentences and match.
2. Ask your child to look at the pictures and color them.

٦ أنشطة لتنمية المهارات العقلية لدى الطفل.

Writing corner

Trace and write the number 1. تتبع واكتب الرقم ١.

Trace and write the number 2. تتبع واكتب الرقم ٢.

Notes for parents:

Help your child trace the numbers and write them.

٥ تنمية مهارات الكتابة.

Activities on Unit 1

1 Listen and circle. استمع وضع دائرة.

1. brother

2. green

3. eye

2 Listen and match. استمع وصل.

daddy mouth arm

3 Listen and tick (✓). استمع وضع علامة (✓) الصحيحة.

1. yellow green

2. eye hand

Notes for parents:

1. Ask your child to listen to each word and circle the correct picture.
2. Ask your child to listen to the words and match them with the correct pictures.
3. Ask your child to listen and tick (✓) the correct word.

٨ أنشطة علي الوحدة.

Review on UNIT 1

parts of body family Color

nose mouth daddy mommy red blue

hair leg brother sister yellow orange

arm foot eyes ears Vocabulary

This is my daddy.

This is my ear.

Language Phonics Bb

lag lussy lree

Hand Hand Hair lana

Notes for parents:

Help your child review Unit 1.

٧ مراجعة عامة على الوحدة تساعد الطفل على مراجعة ما تمكن من تحصيله في الوحدة.



إرشادات مهمة

• عزيزي ولى الأمر ساعد طفلك على تعلم الأوضاع الجيدة للكتابة وطرق الإمساك الصحيحة بالقلم.

١ أوضاع جيدة للطفل عند الكتابة



١- أن يكون المقعد فى ارتفاع مناسب للطفل.

٢- أن يضع الطفل ذراعيه على مقدمة المقعد عند الكتابة.

٢ أوضاع خاطئة للطفل عند الكتابة



٣ طرق ذات كفاءة وفاعلية عند الإمساك بالقلم الجاف أو الرصاص

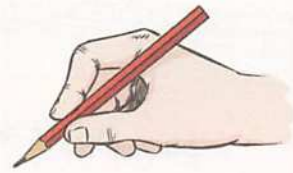
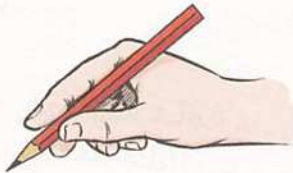



Prewriting worksheet



How to use the pencil

كيفية استخدام القلم الرصاص

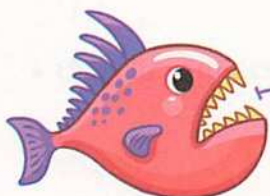

Writing guidelines

• السطور الأربعة المستخدمة في هذا الكتاب تساعد على ضبط حجم وشكل الحرف وتحسين الخط.

Plane line خط (الطائرة) •

Sky line خط (السماء) • هو الخط الأعلى وبعض الحروف تكون صاعدة لهذا الخط.

Grass line خط (الحشائش) • تكتب معظم الحروف بين خطي الطائرة والحشائش.

Worm line خط (الدودة) • هو الخط الأسفل وبعض الحروف تكون هابطة لهذا الخط.

Capital letters shapes :

• تكتب الحروف الكبيرة (Capital letters) بين خط السماء وخط الحشائش.



Small letters shapes :

• تكتب الحروف الصغيرة (Small letters) بين خط الطائرة وخط الحشائش.



• بعض الحروف الصغيرة (Small letters) تكون صاعدة لأعلى (بين خطي السماء والحشائش).



• بعض الحروف الصغيرة (Small letters) تكون هابطة لأسفل (بين خطي الطائرة والدودة).





How to improve your handwriting

أنشطة تساعدك على تحسين الخط

★ Look and write.

- Median letters.

• بعض الحروف التي تكتب في الوسط (بين السطرين).

a c e i m n o r s u v w x z

- Ascenders letters.

• بعض الحروف التي تكتب للأعلى.

b d f h k l t

- Descenders letters.

• بعض الحروف التي تكتب لأسفل.

g j p q y

- Capital letters are always upper. • الحروف الكبيرة (Capital letters) تكون دائماً للأعلى.

A B C D E F G H

• Ask your child to look at the written letters and write them again.

– اطلب من طفلك أن ينظر إلى الحروف المكتوبة ويكتبها مرة أخرى.



The Alphabet

٢. حروف الهجاء

★ Look and trace.

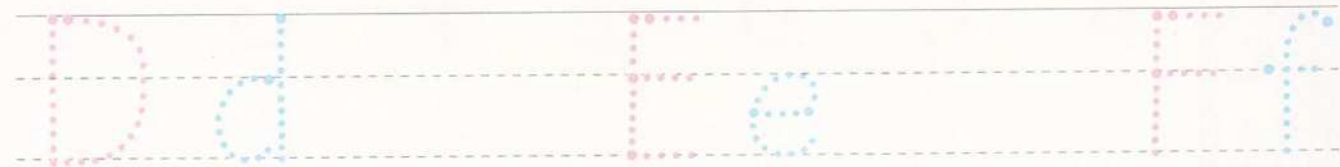
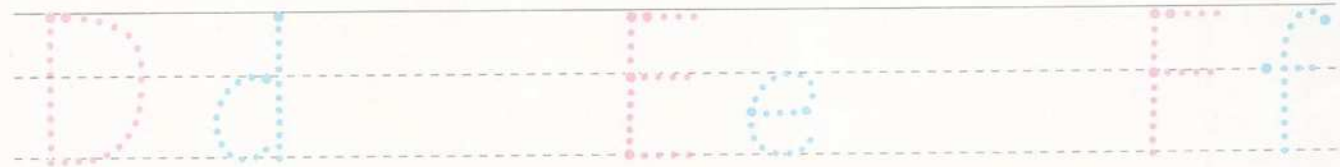
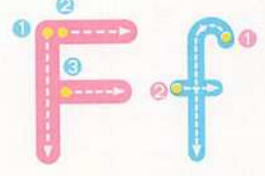
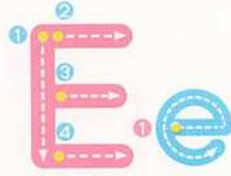
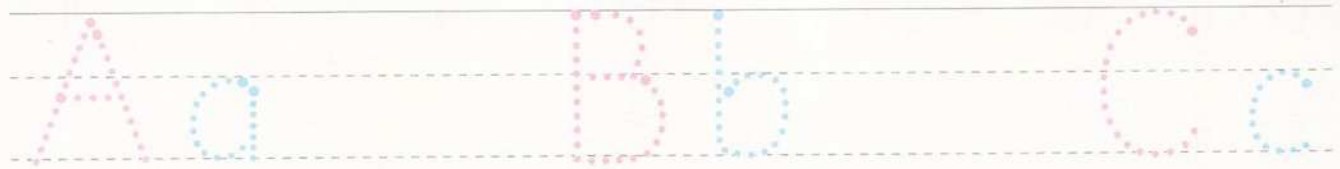
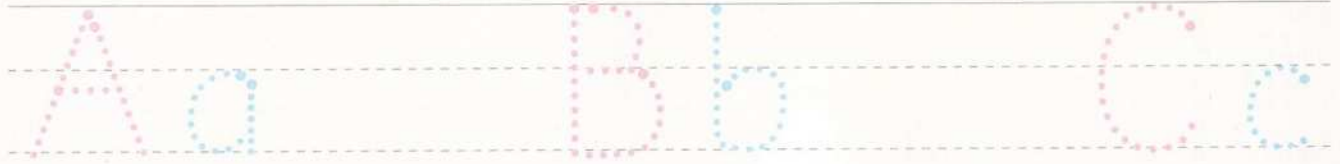

Gg

Hh

Ii

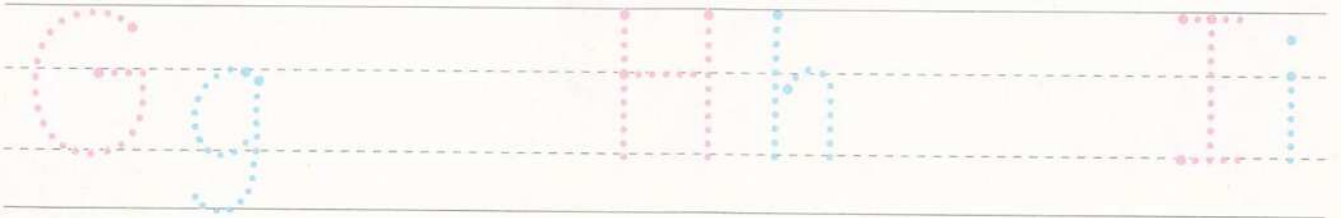
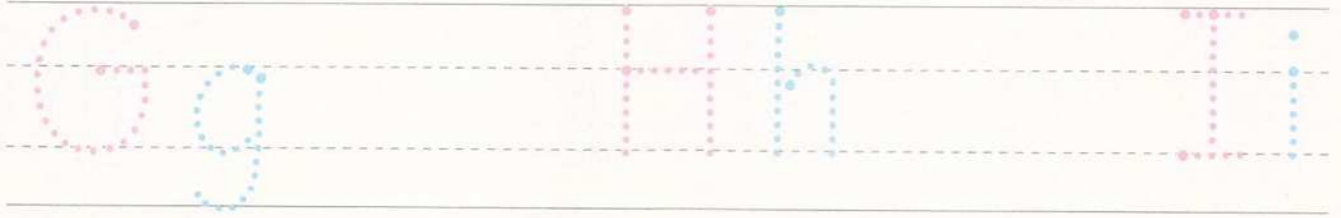

Jj

Kk

Ll

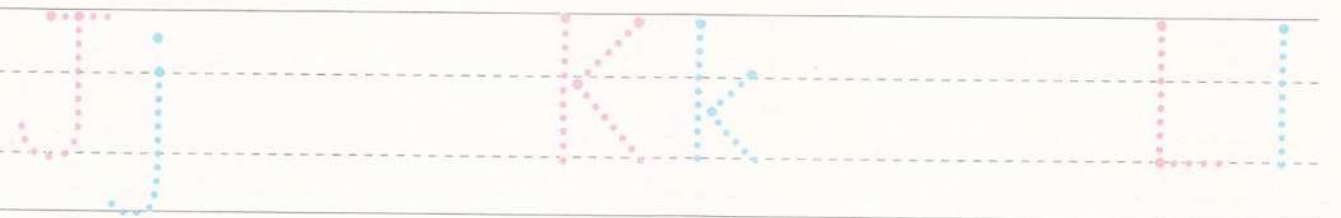
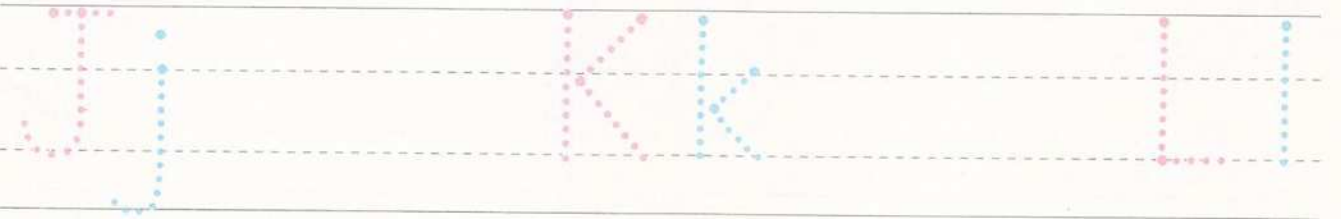

r r R R b b O O d d d d

r r R R b b O O d d d d



o o O O n n N N m m M M

o o O O n n N N m m M M



S s

T t

U u

V v

S s T t U u V v

S s T t U u V v

W w

X x

Y y

Z z

W w X x Y y Z z

W w X x Y y Z z

Contents

THEME 1 Who am I ?

- Unit 1 This is me ! 20
- Unit 2 In my classroom 74

THEME 2 The world around me

- Unit 3 Our animals 130
- Unit 4 Our world 178
- Story The Boys and the Frogs 234



THEME

1

Who am I?



Unit

1

This is me !

هذا أنا!



Unit 1 Objectives



Lessons 1 & 2

Objectives :

- To identify basic family members
- أن يتعرف على أعضاء الأسرة الأساسيين

Vocabulary :

- Adam, Dina, daddy, mommy, brother, sister
- آدم، دينا، أب، أم، أخ، أخت

Lessons 3 & 4

Objectives :

- To talk about family
- أن يتحدث عن العائلة

Vocabulary :

- brother, daddy, mommy, sister
- أخ، أب، أم، أخت

Lesson 5

Objectives :

- To be able to distinguish between 1 and 2 in numerals and concept
- أن يكون قادرًا على التمييز بين رقم 1 ورقم 2 بين الأعداد
- To talk about facial features (two ears, one mouth)
- أن يتحدث عن ملامح الوجه (أذنين، فم)

Vocabulary :

- eyes, ears, mouth, nose, hair
- عيون، أذن، فم، أنف، شعر

Language :

- I have two ears, I have one mouth.
- أنا لدى اذنين، ولدى فم.

Lessons 6 & 7

Objectives :

- To identify parts of the body
- أن يتعرف على أجزاء الجسم
- To sing a song and do actions
- أن يغنى أغنية ويقوم بأفعال
- To talk about eye color
- أن يتحدث عن لون العين

Vocabulary :

- arm, foot, hand, leg
- ذراع، قدم، يد، ساق
- brown, blue, green
- لون بني، أزرق، أخضر

Language :

- Touch your arm, touch your leg, etc.
- المس ذراعك، المس ساقك.

Lesson 8

Objectives :

- To link body parts with the senses
- أن يربط بين أجزاء الجسم والحواس
- To be able to differentiate between them
- أن يكون قادرًا على التمييز بينهم

Vocabulary :

- nose, hand, mouth, ears, eyes, see, smell, hear
- أنف، يد، فم، أذنين، عيون، يرى، يشم، يسمع

Language :

- I smell with my nose.
- أنا أشم بأنف.

Lessons 9 & 10

Objectives :

- To be able to say and find b/B and h/H orally and in writing
- أن يكون قادرًا على قول وإيجاد حرف (Bb)، (Hh) نطقًا وكتابة

Vocabulary :

- Busy Bee, bye, blue, brown, hello, hair, hand, Hana
- النحلة النشيطة، إلى اللقاء، أزرق، بني، أهلاً، شعر، يد، هنا

Lessons 11 & 12

Objectives :

- To identify and match colors to objects of the same color
- أن يتعرف على الألوان و يصلها مع الأشياء من نفس اللون

Vocabulary :

- red, blue, yellow, green, orange, brown, It's
- أحمر، أزرق، أصفر، أخضر، برتقالي، بني، أنه ...
- I like ...
- أنا أحب ...

Lesson 13

- Objectives : - To listen and follow a picture story

- أن يستمع ويتتبع قصة مصورة



Vocabulary

★ Listen and repeat. استمع وردد.

daddy أب



mommy أم



sister أخت



brother أخ

Notes for parents

★ Listen, look and role-play : (with the masks ).

استمع، انظر وتبادل الأدوار : (باستخدام الأقنعة).



Hello! I'm Busy Bee.
This is my family. Buzzzzz.
اهلا! انا النحلة النشيطة. هذه عائلتي.

Hello! My name
is Dina. This is
my mommy. This
is my brother,
Adam.

اهلا اسمي دينا. هذه
امي. هذا اخي آدم.

My name is
Adam. This is
my daddy. This
is my sister,
Dina.

اسمي آدم. هذا ابي.
هذه اختي دينا.

• Help your child listen to the dialogue. then look at the pictures and role-play with his/her colleagues with the masks

ساعد طفلك في الاستماع إلى المحادثة ثم النظر إلى الصور ثم اطلب منه ان يتبادل الادوار مع زملائه باستخدام الأقنعة.

Writing corner

لإتقان مهارة
الكتابة أنظر
كراسة المعاصر
التفاعلية



★ Listen and trace. استمع وتتبع.

mommy



mommy

mommy

mommy

mommy

mommy

daddy



daddy

daddy

daddy

daddy

daddy

sister



sister

sister

sister

sister

sister

brother



brother

brother

brother

brother

brother

Notes for parents

Activities on Lessons 1&2



Put a sticker according to your assessment

1 Listen and circle. استمع وضع دائرة.

1. daddy



2. brother



3. mommy



2 Listen and match. استمع وصل.

Adam

sister

daddy



3 Listen and tick (✓). استمع وضع علامة (✓).

1.



mommy

daddy

2.



Dina

Adam

1. Ask your child to listen to the words and circle the correct picture.

- اطلب من طفلك أن يستمع إلى الكلمات ويضع دائرة حول الصورة الصحيحة.



2. Ask your child to listen to the words and match them with the correct pictures.

- اطلب من طفلك أن يستمع إلى الكلمات ويصل الكلمات بالصورة الصحيحة.



3. Ask your child to listen and tick (✓) the correct word.

- اطلب من طفلك أن يستمع ويضع علامة (✓) أمام الكلمة الصحيحة.

4 Trace and Color. تتبع ولون.

1. 	2. 	3. 
daddy	mommy	brother

5 Trace and circle. تتبع وضع دائرة.

1.  d m n mommy	2.  s t b brother
---	--

6 Look and circle (✓) or (X). انظر وضع دائرة حول علامة (✓) او (X).

1.  sister ✓ / X	2.  mommy ✓ / X	3.  daddy ✓ / X
--	---	---

Notes for parents

4. Ask your child to trace the dotted words and color the pictures.

5. Ask your child to trace and circle the correct letter.

6. Ask your child look and circle (✓) or (X) according to the given word.

- اطلب من طفلك أن يتتبع الكلمات ويلون الصور .

- اطلب من طفلك أن يتتبع الحرف المكتوب على شكل نقاط ويضع دائرة حول الحرف الصحيح المناسب له.

- اطلب من طفلك أن ينظر ويضع دائرة حول علامة (✓) او (X) طبقاً للكلمة المعطاة له.

- Language use
- Vocabulary

Vocabulary

★ Listen and repeat. استمع وردد.

eye عين

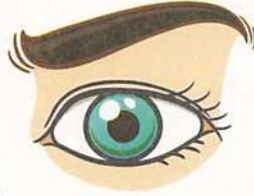

nose انف

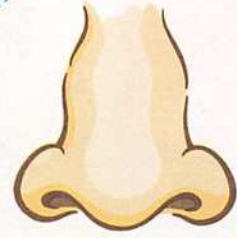

mouth فم



Parts of
the body

أجزاء الجسم



ear اذن

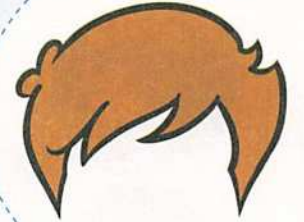

hair شعر



Language

1 We use **(This)** when something or someone is close to us.

This is (my)



2 Introduce yourself.



Notes for parents

- Help your child to identify and express something / someone close to him / her using the demonstrative pronoun (This...).
- ساعد طفلك على أن يتعرف ويعبر عن شيء أو شخص قريب منه / منها باستخدام ضمير الإشارة (This...).
- Help your child to introduce himself / herself using "I'm ... + الاسم".
- ساعد طفلك في تقديم نفسه / نفسها باستخدام (الاسم + I'm).

Activity 1

★ Stick, Color and write. الصق ، لون واكتب.



1. Help your child stick his / her photo and one of his / her family members, color the frame and write his/her name.

– ساعد طفلك أن يلصق صورته وصورة احد أفراد عائلته ويلون الإطار ويكتب اسمه / اسمها.

Activity 2

★ Which one is similar ? Circle and Color.

اس منهم متشابه ؟ ضع دائرة ولون.

1. This is my daddy.



2. This is my brother.



3. This is my mommy.



Notes for parents

Writing corner

لإتقان مهارة
الكتابة انظر
كراسة المعاصر
التفاعلية



★ Listen and trace. استمع وتتبع.

eye



eye

eye

eye

eye

eye

nose



nose

nose

nose

nose

nose

mouth



mouth

mouth

mouth

mouth

mouth

hair



hair

hair

hair

hair

hair

Activities on Lessons 3 & 4



Put a sticker according to your assessment

1 Listen and circle. استمع وضع دائره.

1. nose

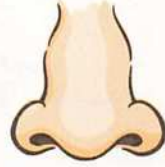

2. ear

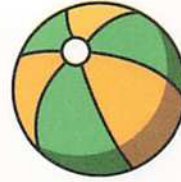

3. hair



2 Listen and match. استمع وصل.

eye

mouth

ear



3 Listen and tick (✓). استمع وضع علامة (✓).

1.



eye

nose

2.



ear

mouth

Notes for parents

1. Ask your child to listen to the words and circle the correct picture.

- اطلب من طفلك أن يستمع إلى الكلمات ويضع دائرة حول الصورة الصحيحة.



2. Ask your child to listen to the words and match them with the correct pictures.

- اطلب من طفلك أن يستمع إلى الكلمات ويصل الكلمات بالصورة الصحيحة.



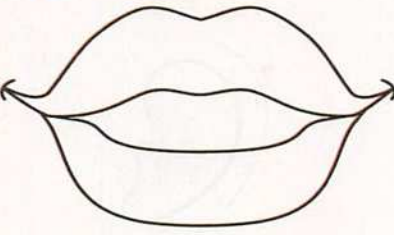
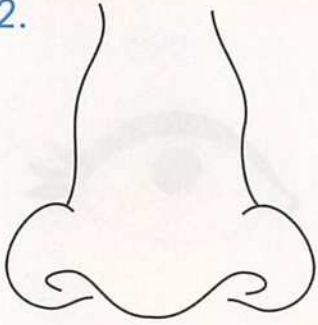

3. Ask your child to listen and tick (✓) the correct word.

- اطلب من طفلك أن يستمع ويضع علامة (✓) أمام الكلمة الصحيحة.

4 Trace and Color. تتبع ولون.

1.  mouth	2.  nose	3.  hair
--	---	---

5 Listen and circle. استمع وضع دائرة.

1.  It's my <u>mouth</u> ear	2.  This is my <u>brother</u> mommy
3.  This is my <u>hair</u> mouth	4.  This is my <u>hair</u> nose

6 Trace. تتبع.

Hello! I'm Adam

4. Ask your child to trace the dotted words and color the pictures.

- اطلب من طفلك أن يتتبع الكلمات ويلون الصور .

5. Ask your child to listen to the sentences and circle the correct answer according to the given pictures.

- اطلب من طفلك أن يستمع الي الجمل ويضع دائرة حول الإجابة الصحيحة طبقاً للصور المعطاة .

6. Ask your child to trace the given sentence.

- اطلب من طفلك أن يتتبع الي الجملة المعطاة .

7 Trace and Color. تتبع ولون.

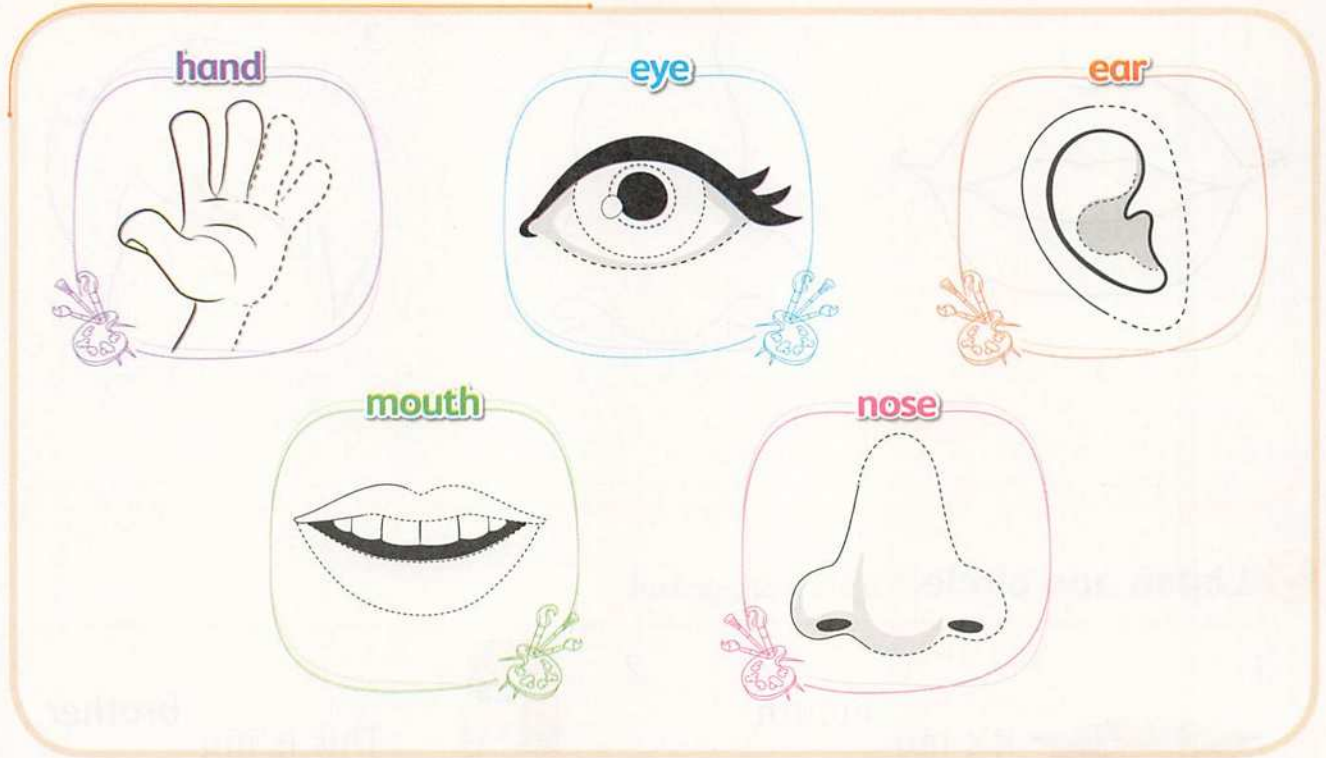

8 Stick. الصق.



Notes for parents

Language

1 have

للتعبير عن ملكيتي لشيء ما :

I

have

one nose.



I **have** two arms.
أنا أمتلك ذراعين.



I **have** one mouth.
أنا أمتلك فم واحد.

2 Plural

صيغة الجمع :



★ Most plural nouns end with "s". معظم أسماء الجمع تنتهي بحرف "s".

Singular المفرد

Plural الجمع



one ear



two ears



one arm



two arms



- Help your child to identify and use verb have with the subject pronoun (I) to express possession.
- ساعد طفلك في أن يتعرف علي ويستخدم الفعل "have" مع ضمير الفاعل (I) للتعبير عن الملكية.
- Help your child to identify that most nouns change into plural by adding "s".
- ساعد طفلك في التعرف على معظم الأسماء التي يتم جمعها بإضافة "s" إليها.

Writing corner

لا تقان مهارة
الكتابة انظر
كراسة المعاصر
التفاعلية



★ Trace and write the number 1. تتبع واكتب الرقم ١.

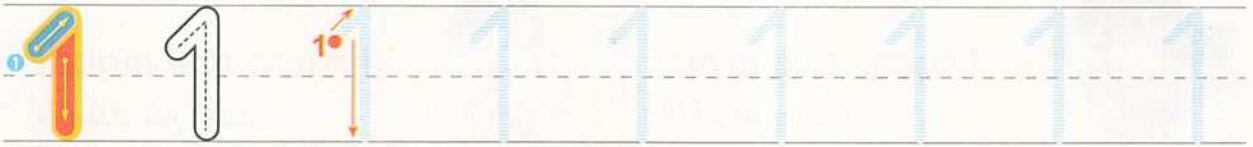
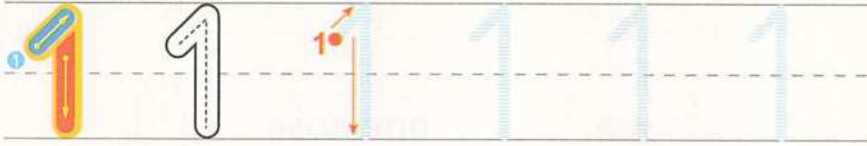

★ Trace and write the number 2. تتبع واكتب الرقم ٢.



Notes for parents

Activities on Lesson 5



Put a sticker according to your assessment

1 Look and circle. انظر وضع دائرة.

1. 2.

2 Match. صل.

3 Count and circle. عد وضع دائرة.

1. 2. 3.
 1 2 1 2 1 2

1. Ask your child to look at each number and circle the suitable picture.

- اطلب من طفلك أن ينظر إلى كل رقم ويضع دائرة حول الصورة المناسبة.

2. Ask your child to match each number with its correct picture.

- اطلب من طفلك أن يصل كل رقم بالصورة الصحيحة.

3. Ask your child to count the objects and circle the right number.

- اطلب من طفلك أن يعد الأشياء ويضع دائرة حول الرقم الصحيح للصورة.

4 Count, write and Color. عد ، اكتب ولون.

1.

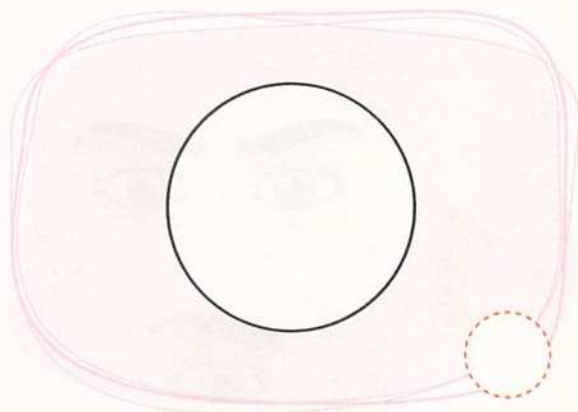

2.

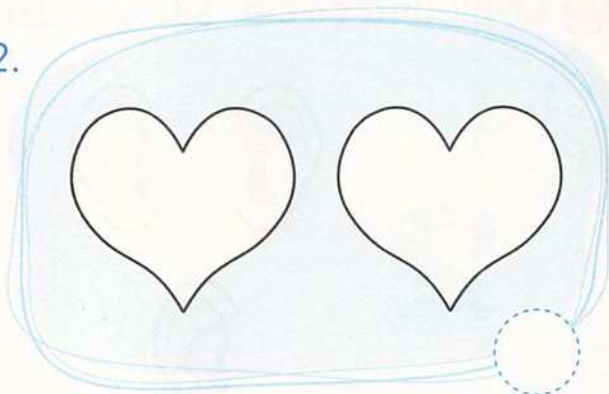

3.

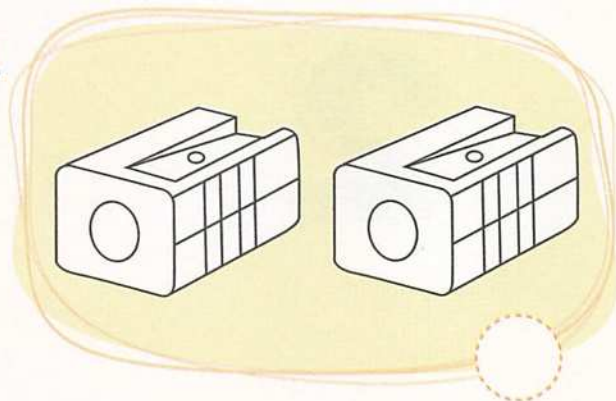

4.

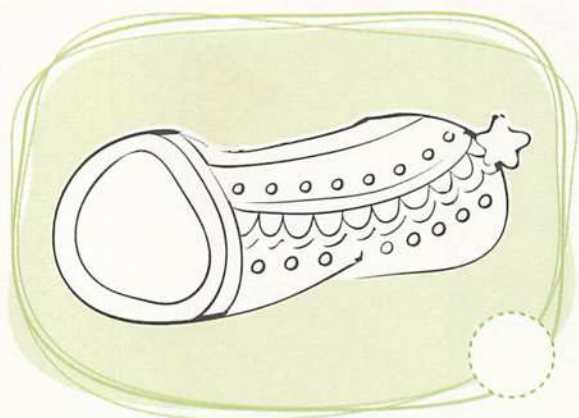

5.

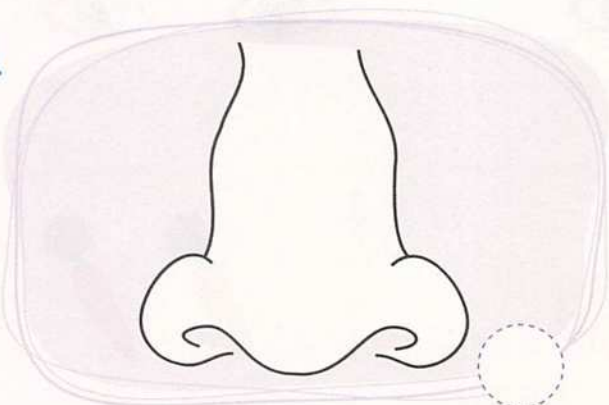

6.

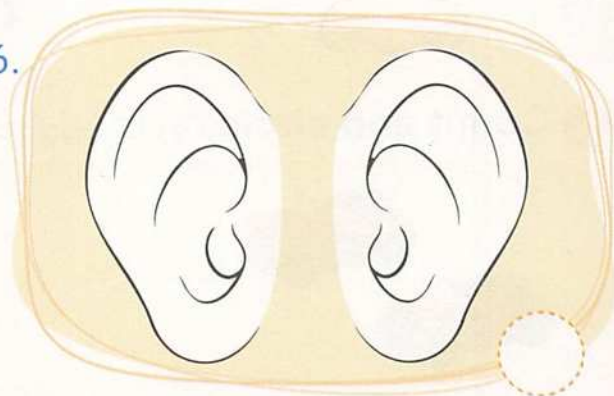

Notes for parents

Lessons
6&7

- Listening and Speaking
- Life skills



Vocabulary

★ Listen and repeat. استمع وردد.

arm ذراع

hand يد

leg ساق

foot قدم



green



brown



blue

Sing & do

Arm, arm, touch your arm.
Leg, leg, touch your leg.
Touch your arm,
Touch your leg !
Touch your arm,
Touch your leg !



Hand, hand, touch your hand.
Foot, foot, touch your foot.
Touch your hand,
Touch your foot !
Touch your hand,
Touch your foot !



Touch your arm.
المس ذراعك.



Touch your foot.
المس قدمك.



Touch your leg.
المس ساقك.

Notes for parents

★ Listen and trace. استمع و تتبع.



We are all beautiful.
نحن جميعاً رائعون.



I have brown eyes.
انا لادي عيون بنية اللون.



I have green eyes.
انا لادي عيون خضراء اللون.



I have blue eyes.
انا لادي عيون زرقاء اللون.

• Help your child to listen to the sentences and trace the words.

- ساعد طفلك أن يستمع إلى الجمل ويتتبع الكلمات.

Writing corner

لإتقان مهارة
الكتابة انظر
كراسة المعاصر
التفاعلية



★ Listen and trace. استمع و تتبع.

arm



arm

arm

arm

arm

arm

hand



hand

hand

hand

hand

hand

leg



leg

leg

leg

leg

leg

foot



foot

foot

foot

foot

foot

Notes for parents

Activities on Lessons 6 & 7



Put a sticker according to your assessment

1 Listen and circle. استمع وضع دائره.

1. arm



2. leg

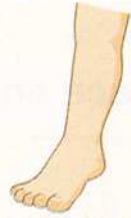

3. foot

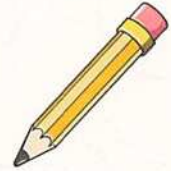

2 Listen and match. استمع وصل.

hand

foot

arm

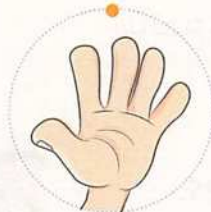

3 Listen and tick (✓). استمع وضع علامة (✓).

1.



arm

leg

2.



hair

hand

1. Ask your child to listen to the words and circle the correct picture.

- اطلب من طفلك أن يستمع إلى الكلمات ويضع دائرة حول الصورة الصحيحة.

2. Ask your child to listen to the words and match them with the correct pictures.

- اطلب من طفلك أن يستمع إلى الكلمات ويصل الكلمات بالصور الصحيحة.

3. Ask your child to listen and tick (✓) the correct word.

- اطلب من طفلك أن يستمع ويضع علامة (✓) أمام الكلمة الصحيحة.

4 Listen and circle. استمع وضع دائرة.

1. I have green eyes.



2. I have brown eyes.



5 Trace and Color. تتبع ولون.

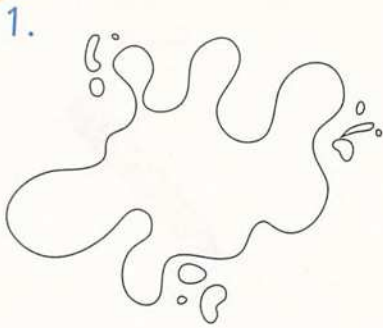

blue

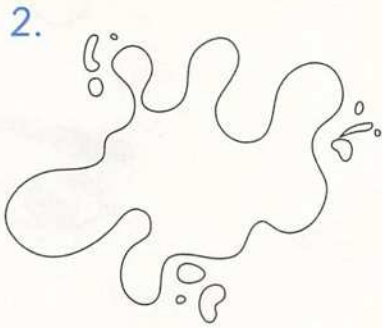

green

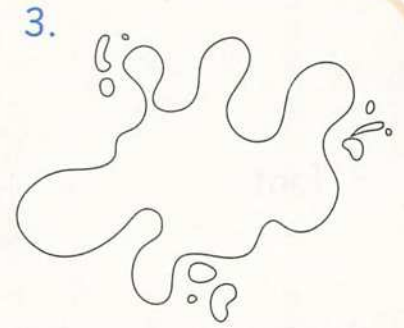

brown

6 Listen and circle. استمع وضع دائرة.

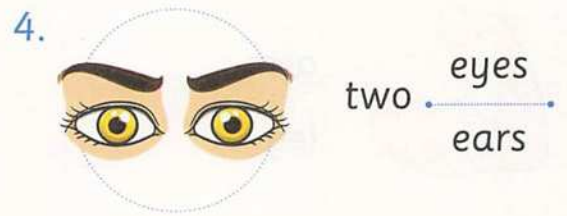
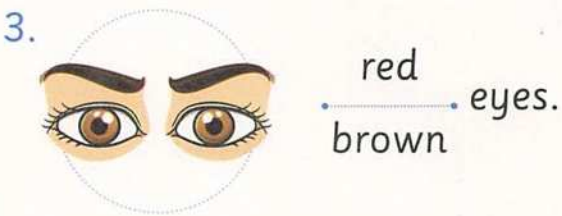
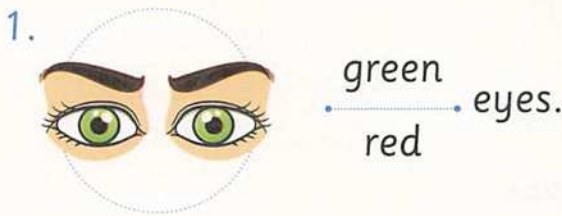

Notes for parents

4. Ask your child to listen to the sentences and circle the correct picture.

- اطلب من طفلك أن يستمع إلى الجمل ويضع دائرة حول الصورة الصحيحة.

5. Ask your child to trace the words and color the pictures.

- اطلب من طفلك أن يتتبع الكلمات ويلون الصور.

6. Ask your child to listen to the sentences and circle the correct answer according to the given pictures.

- اطلب من طفلك أن يستمع إلى الجمل ويضع دائره حول الاجابه الصحيحة طبقاً للصور المعطاة.

- My senses
- Connect with Science

★ Listen and repeat. استمع وردد.

smell

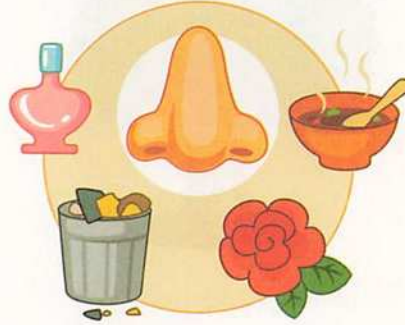

I **smell** with my nose.
أنا أنشم بأنفى.

touch



I **touch** with my hand.
أنا ألمس بيدي.

hear



I **hear** with my ears.
أنا أسمع بأذنانى.

see



I **see** with my eyes.
أنا أرى بعينى.

taste



I **taste** with my mouth.
أنا أتذوق بغمى.



Activity 1

★ Circle the items you can see.

ضع دائرة حول الأشياء التي تستطيع أن تراها.

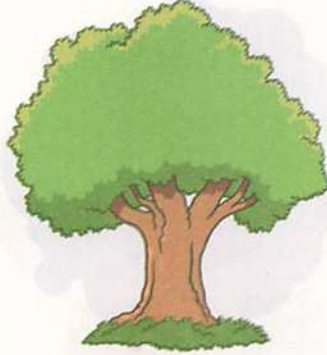
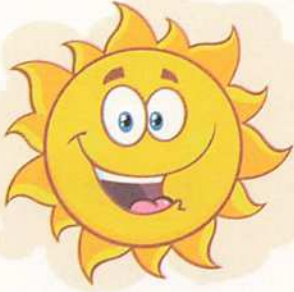

Notes for parents

Activity 2

★ Circle the items you can hear.

ضع دائرة حول الأشياء التي تستطيع أن تسمعها.

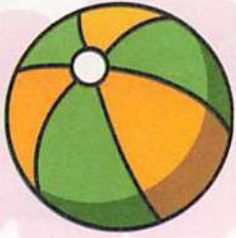

2. Help your child circle the items he / she can hear.

- ساعد طفلك أن يضع دائرة حول الأشياء التي يستطيع / تستطيع سماعها.

Activity 3

★ Circle the items you can touch.

ضع دائرة حول الأشياء التي تستطيع أن تلمسها.



Notes for parents

Activity 4

★ Circle the items you can smell.

ضع دائرة حول الأشياء التي تستطيع أن تشمها.

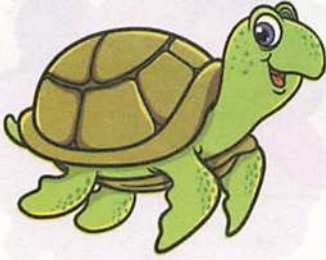

4. Help your child circle the items he / she can smell.

- ساعد طفلك أن يضع دائرة حول الأشياء التي يستطيع / تستطيع شمها.

Activity 5

★ Circle the items you can taste.

ضع دائرة حول الأشياء التي تستطيع أن تتذوقها.



Notes for parents

Activity 6

★ Trace and match. تتبع وصل.



see



hear



touch

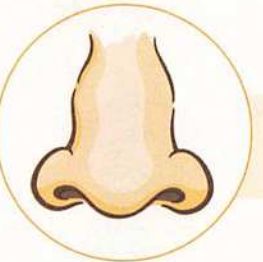

smell



taste

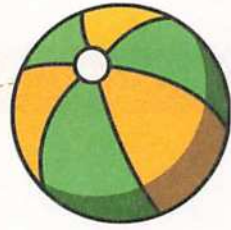

6. Help your child trace the words and match each sense with the suitable picture.

– ساعد طفلك أن يتتبع الكلمات ويصل كل حاسة بالصورة المناسبة لها.

Lessons
9&10

- Learn sounds with Busy Bee!
- Learn to write with Busy Bee!



Vocabulary

★ Listen and repeat. استمع وردد.

bag حقيبة



Busy Bee النحلة النشيطة



Bye ! الى اللقاء ! !



brown لون بني



B b



hand يد

H h



Hana هنا



Hello ! أهلاً !



hair شعر

Notes for parents

• Help your child listen to the words that have the /b/ and /h/ sounds and repeat them.

- ساعد طفلك أن يستمع إلى الكلمات التي تحتوي على الصوتين /b/ و /h/ ويرددها.

Writing

★ Listen and trace. استمع وتتبع.

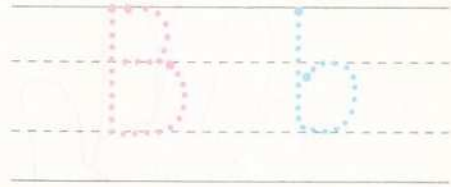

Bye

bag

brown

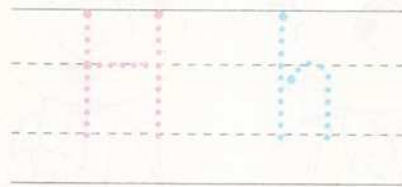
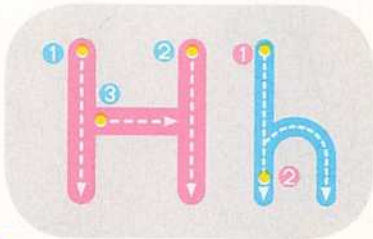

Hello

hair

hand

• Help your child listen to the words that have the /b/ and /h/ sounds and trace the letters.

- ساعد طفلك ان يستمع إلى الكلمات التي تبدأ بالصوتين /b/ ، /h/ ويتتبع الحروف المكتوبة على شكل نقاط.

Activity

★ Color the items beginning with b in red and the items beginning with h in blue.

لون الأشياء التي تبدأ بالصوت / b / بالأحمر والأشياء التي تبدأ بالصوت / h / بالأزرق



Notes for parents

• Help your child color the items beginning with (b) in red and the items beginning with (h) in blue.

- ساعد طفلك أن يلون الأشياء التي تبدأ بحرف (b) باللون الأحمر والأشياء التي تبدأ بحرف (h) باللون الأزرق.

Writing corner

لإتقان مهارة
الكتابة انظر
كراسة المعاصر
التفاعلية

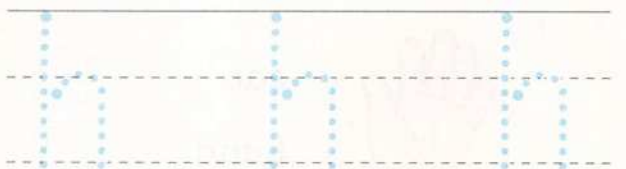
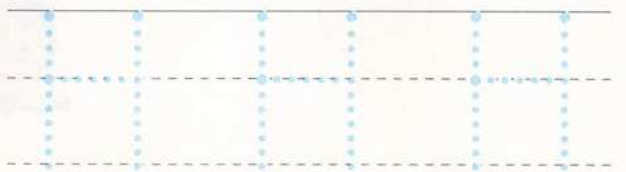
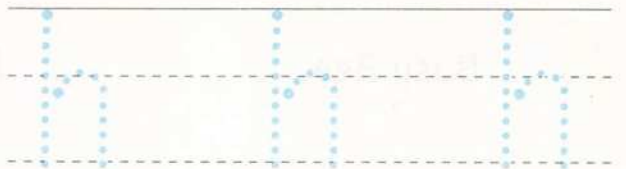
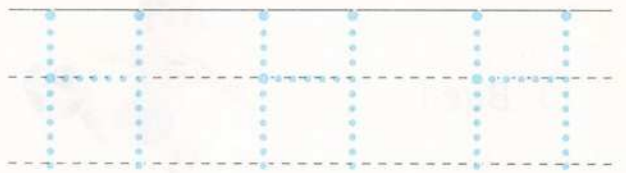
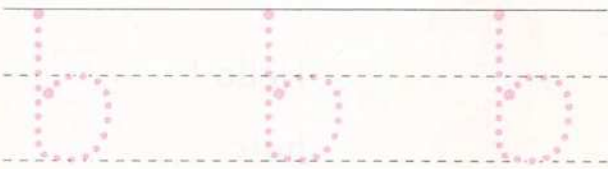
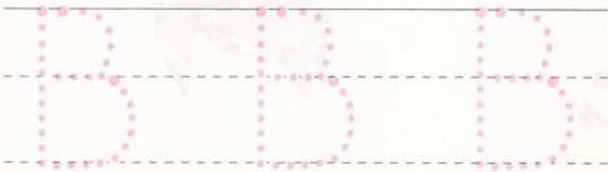
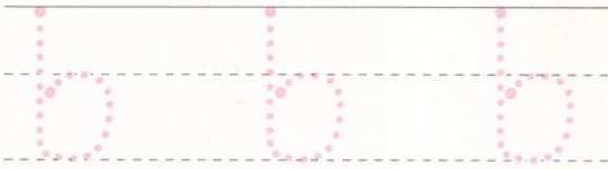
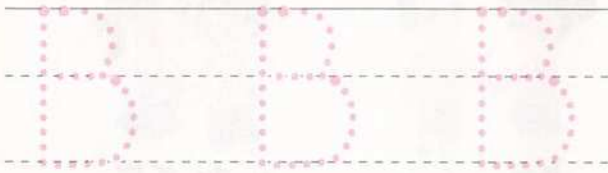
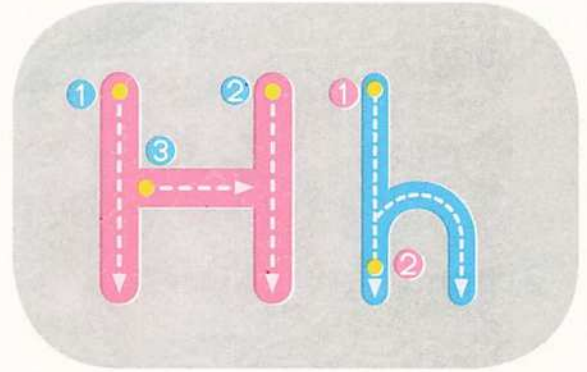
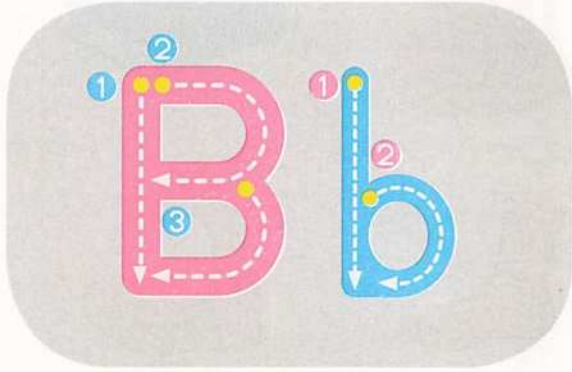

• Ask your child to listen to the /b/ and /h/ sounds and trace the letters (Bb) and (Hh).

- اطلب من طفلك أن يستمع إلى الصوتين /b/ و /h/ ويتتبع الحروف (Bb) و (Hh).

Activities on Lessons 9 & 10



Put a sticker according to your assessment

1 Listen and circle. استمع وضع دائره.

1. bag



2. hand



3. Bye !



2 Listen and match. استمع وصل.

Busy Bee

hair

hand



3 Listen and tick (✓). استمع وضع علامة (✓).

1.



ear

hand

2.



Hello !

hair

Notes for parents

1. Ask your child to listen to the words and circle the correct picture.

- اطلب من طفلك أن يستمع إلى الكلمات ويضع دائرة حول الصورة الصحيحة.

2. Ask your child to listen to the words and match them with the correct pictures.

- اطلب من طفلك أن يستمع إلى الكلمات ويصل الكلمات بالصورة الصحيحة.

3. Ask your child to listen and tick (✓) the correct word.

- اطلب من طفلك أن يستمع ويضع علامة (✓) أمام الكلمة الصحيحة.

4 Circle and write. ضع دائرة وأكتب.

1.



B
S
H

- ello

2.



T
S
B

Busy - ee

5 Trace and Color. تتبع ولون.

1.



Busy Bee

2.

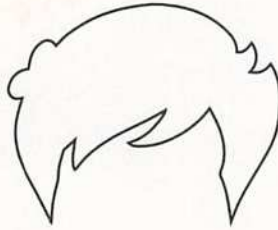

hair

3.



hand

6 Trace and circle. تتبع وضع دائرة.

Hh



Bb



4. Ask your child to circle the correct letter and write it.

5. Ask your child to trace the words and color the pictures.

6. Ask your child to trace the letters and circle the pictures that begin with the given letter.

- اطلب من طفلك أن يضع دائرة حول الحرف الصحيح ويكتبه.

- اطلب من طفلك أن يتتبع الكلمات ويلون الصور.

- اطلب من طفلك أن يتتبع الحروف ويضع دائرة حول الصور التي تبدأ بالحرف المعطى.

- Listening and Speaking
- Connect with art



Vocabulary

★ Listen and repeat. استمع وردد.

orange برتقالي



blue ازرق



brown بني



Colors

ألوان

yellow اصفر



green اخضر



red احمر



Notes for parents

Language

1 We use (like) to express what we love.



I like orange.
أحب اللون البرتقالي.



I like red.
أحب اللون الأحمر.

2 What color is it? ما لونه / لونها ؟

It's لون



What color is it?
ما لونها ؟



It's yellow.
لونها أصفر.



Activity

★ Trace and Color. تتبع ولون .



Red

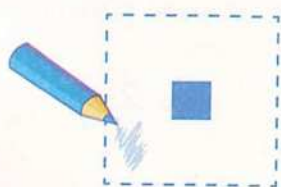

Blue



Yellow

Notes for parents

- Help your child to express what he/she loves.
- Help your child learn how to ask and answer about colors.
- Help your child trace the words and color the shapes according to the given colors.

– ساعد طفلك أن يعبر عما يحب .

– ساعد طفلك أن يتعلم كيف يسأل ويجيب عن الألوان .

– ساعد طفلك أن يتتبع الكلمات ويلون الأشكال طبقاً للألوان المعطاة له .

Activities on Lessons 11&12



Put a sticker according to your assessment

1 Listen and circle. استمع وضع دائرة.

1. green



2. red



3. blue



2 Listen and match. استمع وصل.

orange

red

blue



3 Listen and tick (✓). استمع وضع علامة (✓).

1.



blue

yellow

2.



orange

red

Notes for parents

1. Ask your child to listen to each word and circle the correct color.

- اطلب من طفلك أن يستمع إلى كل كلمة ويضع دائرة حول اللون الصحيح.

2. Ask your child to listen to the words and match them with the correct colors.

- اطلب من طفلك أن يستمع إلى الكلمات ويصل الكلمات بالالوان الصحيحة.

3. Ask your child to listen and tick (✓) the correct word.

- اطلب من طفلك أن يستمع ويضع علامة (✓) أمام الكلمة الصحيحة.

Lesson

13

Story Time



A new color

لون جديد

We can mix colors !

نستطيع أن نخلط الألوان !



☆ Listen, look and role-play : (with the masks ).

استمع، انظر وتبادل الأدوار : (باستخدام الأقنعة).

1

This is my balloon. It's for Mommy.

هذه بالونتي. انها لأمي.

And this is my balloon. It's for Daddy.

وهذه بالونتي. انها لأبي.



2

My balloon is yellow. I like yellow.

بالونتي صفراء اللون. انا احب الالففر.

I like my balloon, too. It's red.

انا احب بالونتي، ايضاً انها حمراء.



Notes for parents

- Help your child listen to the scenes of the story, then look at the pictures and role-play with his/her colleagues with masks.

3

Oh no! The yellow paint !

ياه ! انه دهان اصفر !

Oh no! The red paint !

ياه ! انه دهان احمر !

What color is the paint ?

مالون الدهان؟



4

This is for you Daddy.

هذة لك يا ابي.

This is for you Mommy.

هذة لك يا امي.

I like my balloon. It's orange.

احب بالونتي. لونها برتقالي.

I like my balloon. It's orange,

too ! انها برتقالية اللون, ايضا!

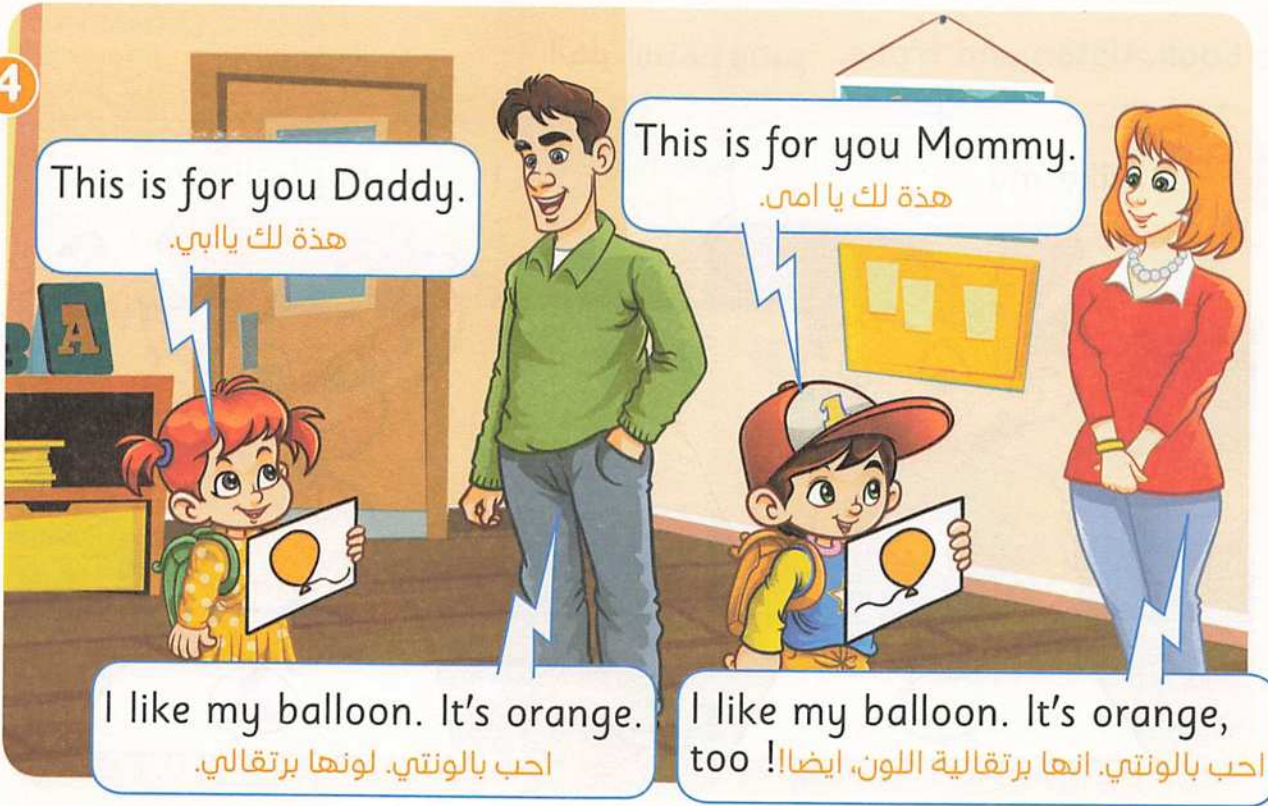

★ Listen and Color. . استمع ولون .

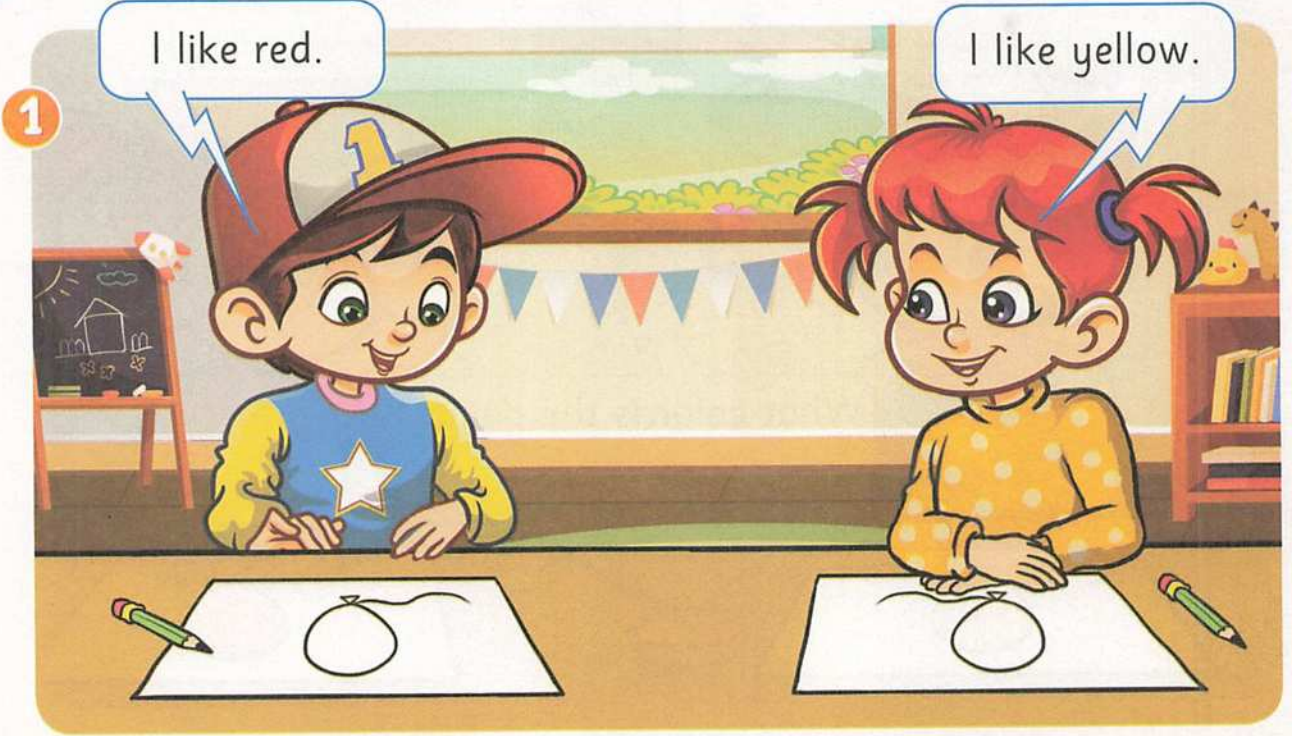

★ Look, listen and trace. . انظر، استمع وتتبع .

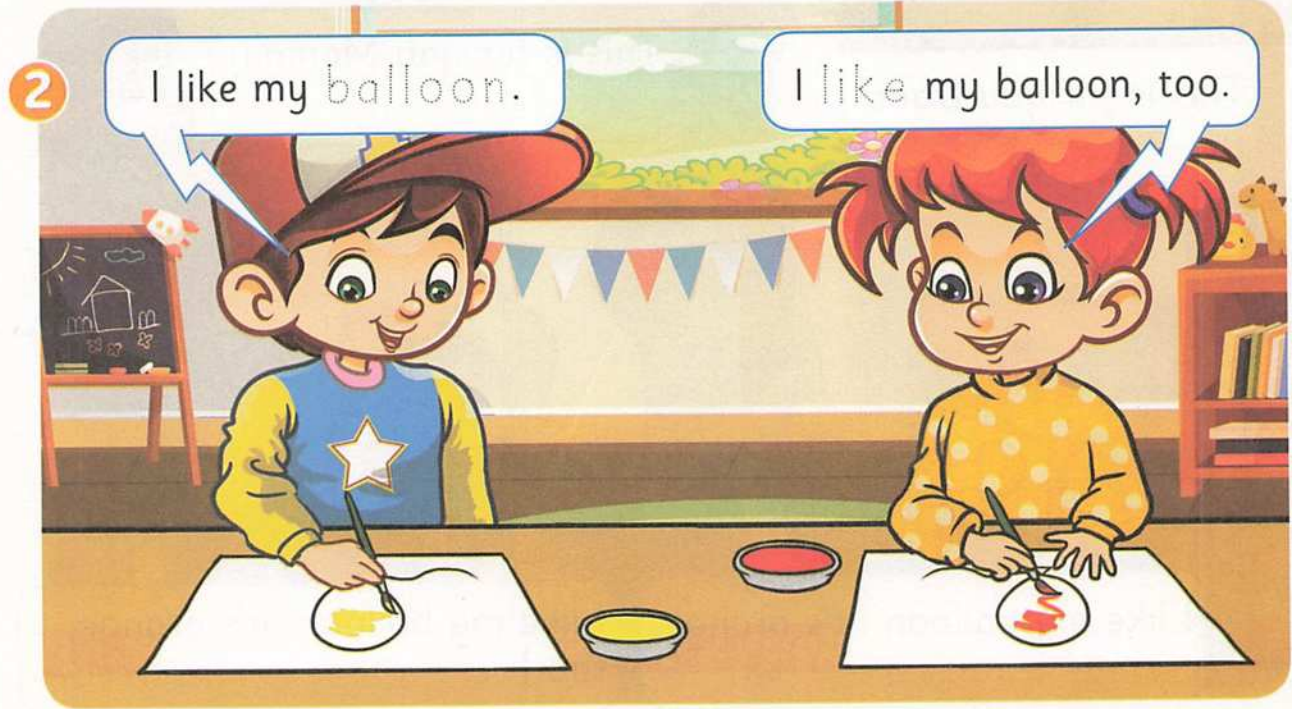

Notes for parents

1. Help your child listen and color the balloon according to the given sentences.

- ساعد طفلك في الاستماع ويلون صورة البالون طبقاً للجمل المعطاة.

2. Help your child to listen and trace the words.

- ساعد طفلك في ان يستمع ويتتبع الكلمات.

Retell



★ **Make a story.** قم بعمل قصة.

Draw

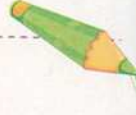

• Help your child make a story with his / her friends by drawing.

- ساعد طفلك في عمل قصة مع صديقه / صديقتها عن طريق رسم صور للقصة.



A new Color

☆ Mix and say. امزج و قل.

☆ Primary colors are :

الالوان الاساسية هي:



Red



Blue



Yellow

☆ Mixing primary colors gives new colors:

عند خلط الالوان الاساسية نحصل على الوان جديدة

Red + Yellow = Orange



Red and yellow make orange.

Blue + Yellow = Green



Blue and yellow make green.

Yellow + Red + Blue = Brown



Yellow, red and blue make brown.

Notes for parents

• Help your child to know how to mix primary colors to form other new colors.

- ساعد طفلك أن يعرف كيف يخلط الألوان الأساسية للحصول على الوان جديدة أخرى.

Activity 1

★ Listen and circle. استمع وضع دائرة.

1. red



2. brown



3. blue



Activity 2

★ Listen and circle. استمع وضع دائرة.

1.



Red and yellow make $\frac{\text{orange}}{\text{blue}}$

2.



It's $\frac{\text{green}}{\text{red}}$

3.



Blue and yellow make $\frac{\text{blue}}{\text{green}}$

4.



Red, blue and yellow make $\frac{\text{brown}}{\text{green}}$

1. Ask your child to listen to each word and circle the correct color.

2. Ask your child to listen to the sentences and circle the correct answer according to the given pictures.
- اطلب من طفلك أن يستمع إلى كل كلمة ويضع دائرة حول اللون الصحيحة.
- اطلب من طفلك أن يستمع إلى الجمل ويضع دائرة حول الإجابة الصحيحة طبقاً للالوان المعطاة.



1 Listen and match. استمع وصل.

1. This is my balloon.



2. It's for daddy.



3. It's orange.



2 Look and color. انظر ولون.

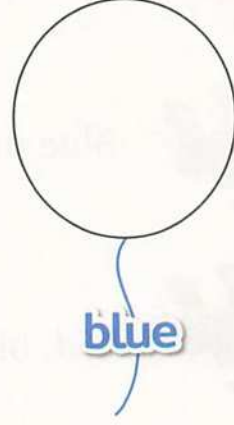
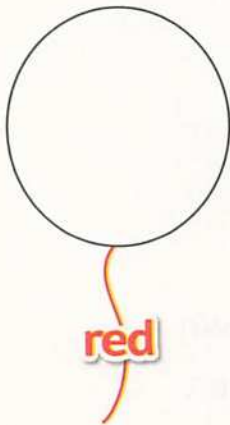

Notes for parents

1. Ask your child to listen to the sentences and match.

- اطلب من طفلك أن يستمع إلى الجمل ويقوم بتوصيل كل جملة بالصورة المناسبة لها.

2. Ask your child to look at the pictures and color them.

- اطلب من طفلك أن ينظر إلى الصور ويلونها.



ارشادات اللعبة

Mo Game

Start →

اطلب من طفلك ان يبحث عن الصور
فى الكروت ويضع كل صورة على الظل
المناسب لها.

Level 1 ★

اطلب من طفلك ان يستمع الي الكلمات
ويبحث عنها فى الكروت ويضع كل كلمة
على الكلمة المناسبة لها.

Level 2 ★

اطلب من طفلك ان يستمع الي الكلمات
ويبحث عن حروف كل كلمة فى الكروت
ويضعها لتكون الكلمة.

Level 3 ★

Level 1



Level 2

n o s e

b a g

a r m

Level 3



hair



blue

1

2

3

4

1

2

3

4

* استخدم كروت اللعبة من كراسة المعاصر التفاعلية.

* يحصل الطفل علي مبلغ Mo kids 50 مكافأة مع كل اجابة صحيحة.

تنويه

* يمكن للطفل ان يلعب وحدة أو يشارك زميل أو أكثر فى اللعبة. والفائز هو من يحصل علي اكثر نقود.

Review on UNIT 1

parts of body



family



Color



Vocabulary

This is me!

Language



This is my daddy.

This is my ear.



Phonics

Bb



bag



Busy Bee

Hh



hand



hair



Hana

Notes for parents

Activities on Unit 1



Put a sticker according to your assessment

1 Listen and circle. استمع وضع دائرة.

1. brother



2. green



3. eye



2 Listen and match. استمع وصل.

daddy

mouth

arm

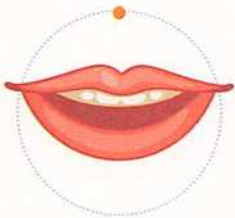

3 Listen and tick (✓). استمع وضع علامة (✓).

1.



yellow

green

2.



eye

hand

1. Ask your child to listen to each word and circle its correct picture.

- اطلب من طفلك أن يستمع إلى كل كلمة ويضع دائرة حول الصورة الصحيحة.

2. Ask your child to listen to the words and match them with the correct pictures.

- اطلب من طفلك أن يستمع إلى الكلمات ويصل الكلمات بالصورة الصحيحة.

3. Ask your child to listen and tick (✓) the correct word.

- اطلب من طفلك أن يستمع ويضع علامة (✓) أمام الكلمة الصحيحة.

Activities on Unit 1

4 Circle and write. ضع دائرة وأكتب.

1.



T
S
B

- usy Bee

2.

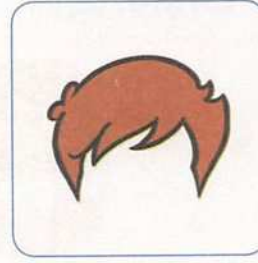

g
h
d

- air

5 Look and circle (✓) or (X). انظر وضع دائرة حول علامة (✓) أو (X).

1.

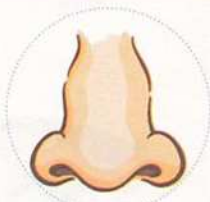

eye

✓ / X

2.



arm

✓ / X

3.



hand

✓ / X

6 Listen and circle. استمع وضع دائرة.

1.



This is my daddy .
mommy .

2.



I see with my eyes .
ears .

3.



Red and yellow make orange .
green .

4.



I have two ears .
legs .

Notes for parents

4. Ask your child to circle the correct letter and write it.

- اطلب من طفلك أن يضع دائرة حول الحرف الصحيح ويكتبه.

5. Ask your child to look and circle (✓) or (X) according to the given word.

- اطلب من طفلك أن ينظر ويضع دائرة حول علامة (✓) أو (X) طبقاً للكلمة المعطاة له.

6. Ask your child to listen to the sentences and circle the correct answer according to the given pictures.

- اطلب من طفلك أن يستمع الى الجمل ويضع دائرة حول الإجابة الصحيحة طبقاً للصور المعطاة.

7 Look and complete. انظر وأكمل.

red - I'm - daddy - legs

1.



This is my

2.



..... Adam.

3.



I have two

4.



I like aballoon .

8 Trace. تتبع.

Bb Bb Bb Bb Bb

Hh Hh Hh Hh Hh

Touch your arm.

This is my sister

7. Ask your child to look at the pictures and complete the sentences from the words in the above box.

- اطلب من طفلك أن ينظر الى الصور ويكمل الجمل من الكلمات التي في الصندوق اعلاه.

8. Ask your child to trace the given letters / sentences.

- اطلب من طفلك أن يتتبع الحروف / الجمل المعطاة.

Unit

2

In my classroom

في فطلي الدراسي



Unit 2 Objectives



Lessons 1, 2 & 3

Objectives :

1. To identify classroom objects

١- أن يتعرف على الأشياء الموجودة في الفصل

2. To use "This is .." to talk about classroom objects

٢- أن يستخدم «هذا/ هذه ...» ليتكلم عن الأشياء الموجودة في حجرة الفصل

Vocabulary :

- pencil, pen, eraser, sharpener, chair, table, board

- قلم رصاص، قلم جاف، استيكة، براية، كرسى، منضدة، سبورة

Language :

- This is (an eraser), (a pen) (قلم) هذه (براية)، هذا (قلم)
- What can you see ? ماذا يمكنك أن ترى ؟

Lessons 4 & 5

Objectives :

1. To recognize numbers 1 to 10

١- أن يتعرف على الأرقام من ١ لـ ١٠

2. To ask and answer "How many ...?"

٢- أن يسأل ويجيب عن (كم عدد ...؟)

Vocabulary :

- one, two, three, four, five, six, seven, eight, nine, ten

- واحد، اثنين، ثلاثة، أربعة، خمسة، ستة، سبعة، ثمانية، تسعة، عشرة

Language :

- How many pencils are there ? There are ...
كم عدد الأقلام الرصاص الموجودة ؟ يوجد ...

Lessons 6 & 7

Objectives :

1. To identify shapes and know how many sides they have

١- أن يتعرف على الأشكال الهندسية ويعرف عدد الأضلاع

2. To write the names of known shapes

٢- أن يكتب أسماء الأشكال الهندسية المعروفة

Vocabulary :

- circle, square, rectangle, triangle

- دائرة، مربع، مستطيل، مثلث

Language :

- A square has four sides. المربع له ٤ أضلاع.
- A circle is round. الدائرة مستديرة.

Lesson 8

Objectives :

1. To describe simple classroom objects

١- أن يصف الأشياء البسيطة الموجودة في الفصل

2. To draw and color classroom objects

٢- أن يرسم ويلون الأشياء الموجودة في الفصل

Lessons 9 & 10

Objectives :

1. To say and write M/m and N/n

١- أن يقول ويكتب حرفي N/n , M/m

2. To trace and write M/m and N/n

٢- أن يتتبع ويكتب حرفي N/n , M/m

Vocabulary :

- mouth, classroom, nose, nurse, Nour, Maha, pen

- فم، فصل دراسي، أنف، ممرضة، نور، مها، قلم جاف

Lessons 11 & 12

Objectives :

1. To learn about people who help us at school

١- أن يتعلم عن الأشخاص الذين يساعدونا في المدرسة

2. To learn and understand about what jobs people do

٢- أن يتعلم ويفهم عن الوظائف التي يقوم بها الأشخاص

Vocabulary :

- teacher, librarian, nurse
معلم (معلمة)، أمين (أمينة) مكتبة، ممرض (ممرضة)

Language :

- My teacher helps me write. يساعدنى معلمى أن أكتب.

Lesson 13

Objectives :

- To be able to listen to and follow a story

- أن يكون قادر على الاستماع واتباع القصة

Lessons
1&2

Vocabulary



Vocabulary

★ Listen and repeat. استمع وردد.

chair كرسي



pencil قلم رصاص

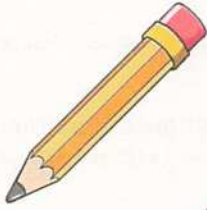

table منضدة



classroom



فصل دراسي

board سبورة



pen قلم جاف

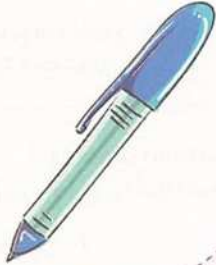

sharpener برآية



eraser أستيكة

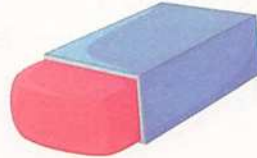

Notes for parents

★ Listen, look and role-play : (with the masks).

استمع، انظر وتبادل الأدوار : (باستخدام الأقنعة).



What can you see?

ماذا تستطيع ان تری؟



I can see a pen.

استطيع ان أرى قلم جاف.



I can see an eraser.

استطيع ان أرى استيكة.



I can see a table.

استطيع ان أرى منضدة.

I can see a pencil.

استطيع ان أرى قلم رصاص.



I can see a sharpener.

استطيع ان أرى براءة.



I can see a chair.

استطيع ان أرى كرسي.



• Help your child to listen to the dialogue, and let him/her say what he/she listens to correctly, then as him/her to role-play it with his/her colleagues.

- ساعد طفلك في الاستماع إلى المحادثة ودعه يقول ما يسمعه بطريقة صحيحة، ثم اطلب منه أن يتبادل الأدوار مع زملائه.

Writing corner

لإتقان مهارة
الكتابة انظر
كراسة المعاصر
التفاعلية



★ Listen and trace. استمع وتتبع.

pen



pen

pen

pen

pencil



pencil

pencil

pencil

eraser

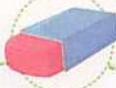

eraser

eraser

eraser

sharpener



sharpener

sharpener

sharpener

chair



chair

chair

chair

board



board

board

board

table



table

table

table

Notes for parents

Activities on Lessons 1&2



Put a sticker according to your assessment

1 Listen and circle. استمع وضع دائرة.

1. sharpener



2. pen



3. board



2 Listen and match. استمع وصل.

eraser

pencil

table

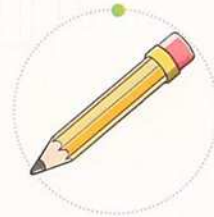
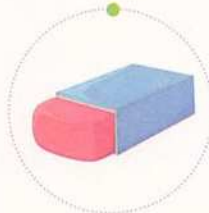

3 Listen and tick (✓). استمع وضع علامة (✓).

1.



pen

pencil

2.



board

table

1. Ask your child to listen to the words and circle the correct picture.

- اطلب من طفلك أن يستمع إلى الكلمات ويضع دائرة حول الصورة الصحيحة.





2. Ask your child to listen to the words and match them with the correct pictures.

- اطلب من طفلك أن يستمع إلى الكلمات ويصل الكلمات بالصورة الصحيحة.

3. Ask your child to listen and tick (✓) the correct word.

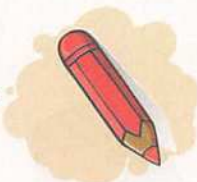
- اطلب من طفلك أن يستمع ويضع علامة (✓) أمام الكلمة الصحيحة.

4 Look and tick (✓). انظر وضع علامة (✓).

1.  • pencil <input type="checkbox"/> • eraser <input type="checkbox"/>	2.  • board <input type="checkbox"/> • chair <input type="checkbox"/>
3.  • chair <input type="checkbox"/> • table <input type="checkbox"/>	4.  • sharpener <input type="checkbox"/> • table <input type="checkbox"/>

5 Trace and Color. تتبع ولون.

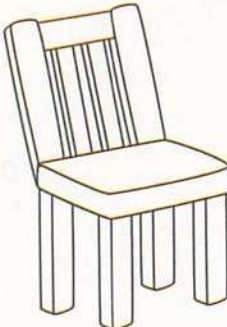
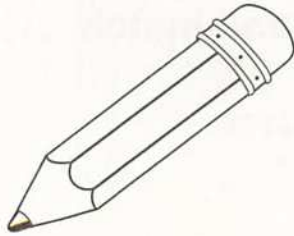
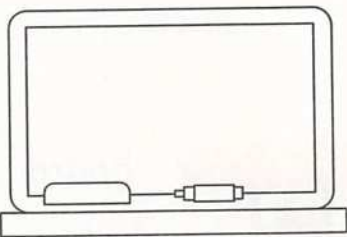
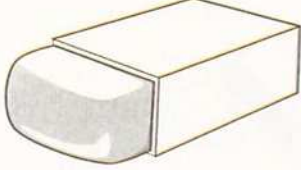
1. chair 	2. pencil 
3. board 	4. eraser 

Notes for parents

4. Ask your child to look at each picture and tick (✓) the correct word.

- اطلب من طفلك أن ينظر إلى كل صورة ويضع علامة (✓) أمام الكلمة الصحيحة.

5. Ask your child to trace the words and color the pictures.

- اطلب من طفلك أن يتتبع الكلمات ويلون الصور.

This is

★ We use (This is) to talk about near singular nouns.

This is a / an singular noun



• Help your child talk about classroom objects by using demonstrative pronoun "This" for near singular.

- ساعد طفلك في أن يتكلم عن الأشياء الموجودة في الفصل باستخدام اسم الإشارة "This" بمعنى هذا / هذه للمفرد القريب.

Using "a" and "an"

1 We use "a" before singular words beginning with a consonant.

١. نستخدم "a" قبل الكلمات المفرد التي تبدأ بصوت حرف ساكن.

Consonant

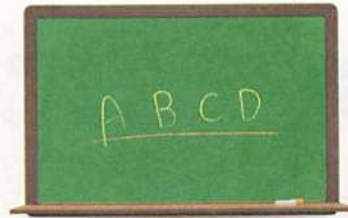
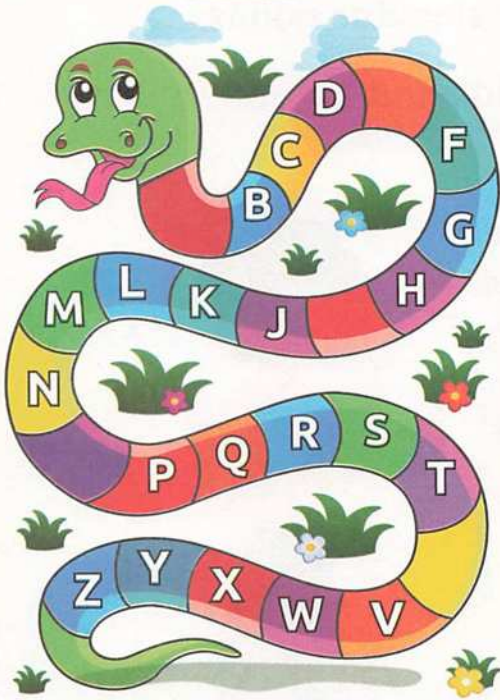

a board



a pencil

2 We use "an" before singular words beginning with a vowel.

٢. نستخدم "an" قبل الكلمات المفرد التي تبدأ بصوت حرف متحرك.

Vowels

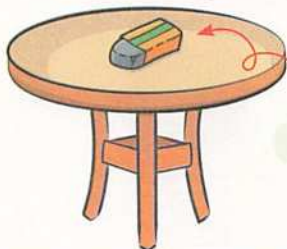

an eraser



Notes for parents

• Help your child to identify the difference between article (a) and article (an) before the singular noun.

- ساعد طفلك في التعرف على الفرق بين أداة النكرة (a) التي تأتي قبل الاسم المفرد الذي يبدأ بحرف ساكن و (an) قبل الاسم المفرد الذي يبدأ بحرف متحرك.

Activity 1

★ Look and stick. انظر والاصق.

1 This is a

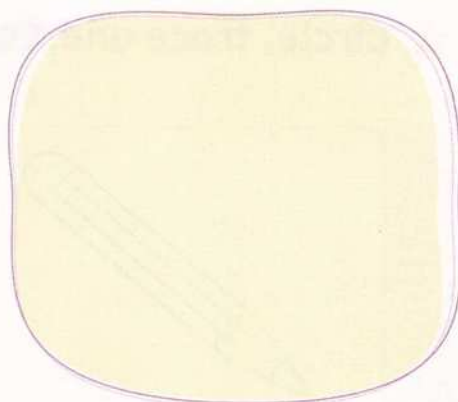

2 This is an

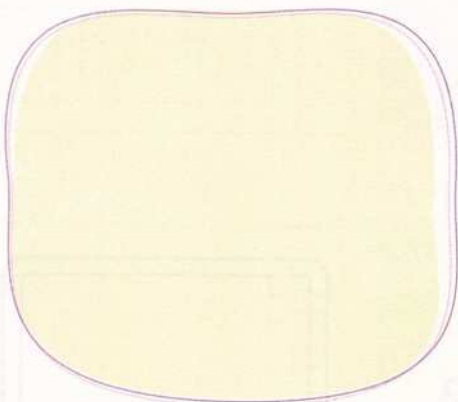

3



4

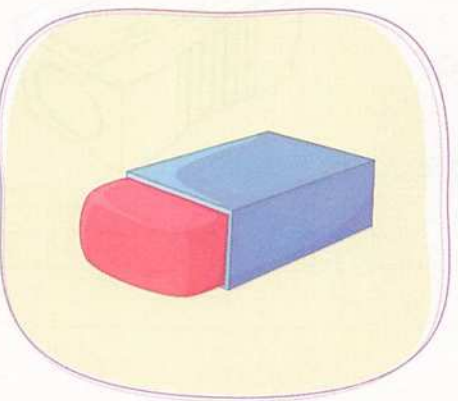

1. Ask your child to look and stick the pictures from El - Moasser Interactive Notebook.

- اطلب من طفلك أن ينظر ويلصق الصور من كراسة المعاصر التفاعلية.

Activity 2

☆ Circle, trace and Color. ضع دائرة ، تتبع ولون.

a
an

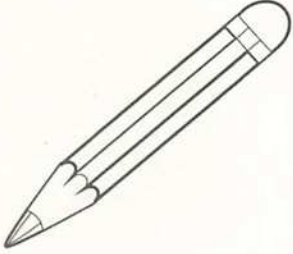

pencil

a
an

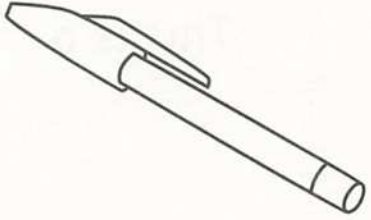

pen

a
an

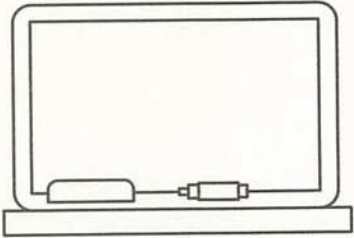

board

a
an

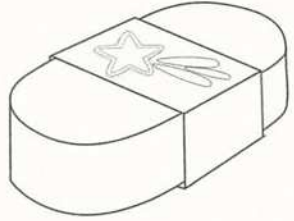

eraser

a
an

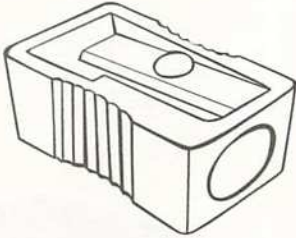

sharpener

a
an



table

Notes for parents

Activities on Lesson 3



Put a sticker according to your assessment.

1 Trace and Color. تتبع ولون.

1.

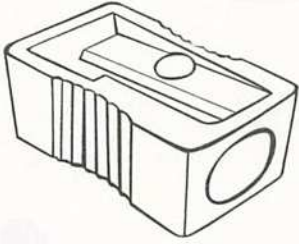

sharpener

2.

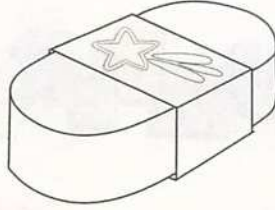

eraser

3.



table

2 Listen and circle. استمع وضع دائرة.

1.



This is a pen .
pencil

2.



This is a board .
table

3.



This is a sharpener .
eraser

4.



This is a board .
pencil

3 Trace. تتبع.

This is a sharpener.

This is a sharpener.

1. Ask your child to trace the words and color the pictures.

2. Ask your child to listen to the sentences and circle the correct answer according to the given pictures.

اطلب من طفلك أن يتتبع الكلمات ويلون الصور.

3. Ask your child to trace the given sentence.

اطلب من طفلك أن يستمع إلى الجمل ويضع دائرة حول الإجابة الصحيحة طبقاً للصور المعطاة.

Lessons
4&5

- Connect with math
- Language use



Vocabulary

★ Listen and repeat. استمع وردد.

NUMBERS الأرقام

1



one

2



two

3



three

4



four

5



five

6



six

7



seven

8



eight

9



nine

10



ten

Notes for parents

• Help your child listen to the numbers and repeat them.

Language

1 There is + **singular noun** • يوجد (للمفرد).

There is one sharpener.
يوجد براية واحدة.



2 There are + **plural noun** • يوجد (للجمع).

There are four sharpeners.
يوجد أربع برايات.



• Help your child to identify and use "There is" for singular noun and "There are" for plural nouns.

- ساعد طفلك ان يتعرف ويستخدم ".... اسم مفرد + There is" بمعنى يوجد للمفرد و ".... اسم جمع + There are" بمعنى يوجد للجمع.

3 How many + اسم جمع يعد are there ? كم عدد ؟

How many pencils are there ?
كم عدد الأقلام الرصاص الموجودة ؟



How many pencils are there ?
كم عدد الأقلام الرصاص الموجودة ؟



Notes for parents

Activity 1

★ How many insects are there in each group ?

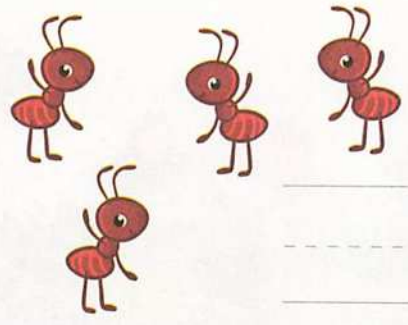

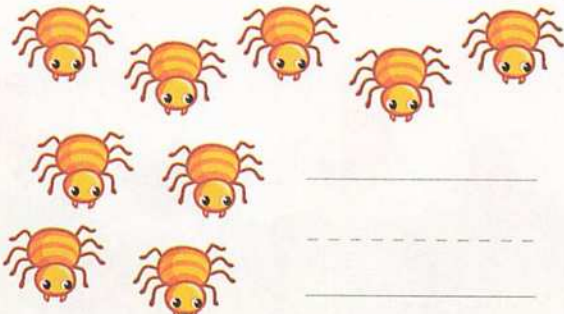

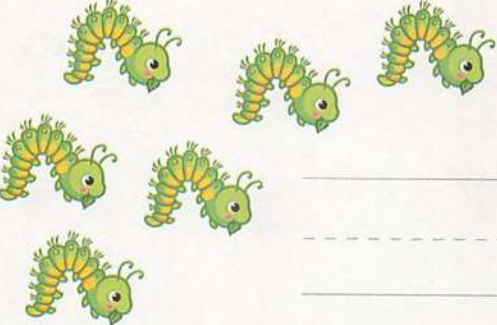



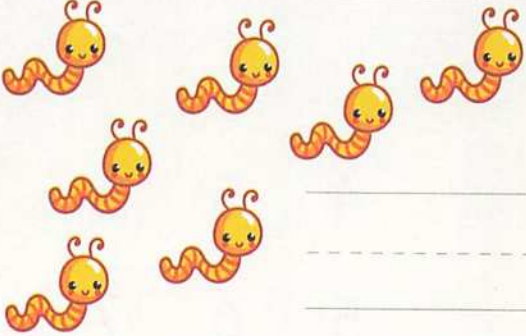

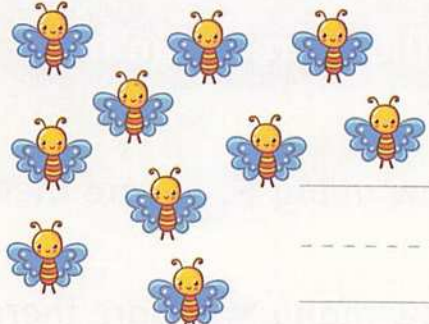

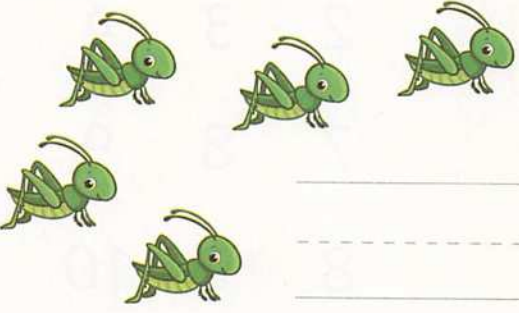

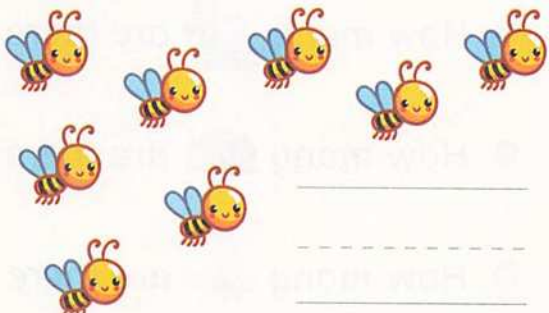

• Help your child to count the insects and write the number.

- ساعد طفلك أن يعد الحشرات ويكتب العدد.

Activity 2

☆ Count and circle. عد وضع دائرة.



Circle the correct number.

- How many  are there ? 4 5 6
- How many  are there ? 5 6 7
- How many  are there ? 2 3 4
- How many  are there ? 7 8 9
- How many  are there ? 8 9 10

Notes for parents

• Help your child to count the insects and circle the correct number.

Writing corner

لإتقان مهارة
الكتابة انظر
كراسة المعاصر
التفاعلية



★ Listen and trace. استمع وتتبع.

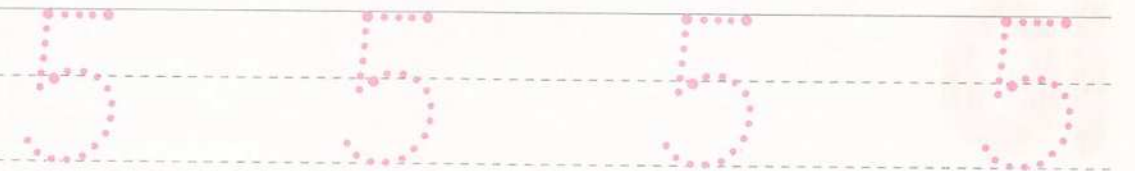
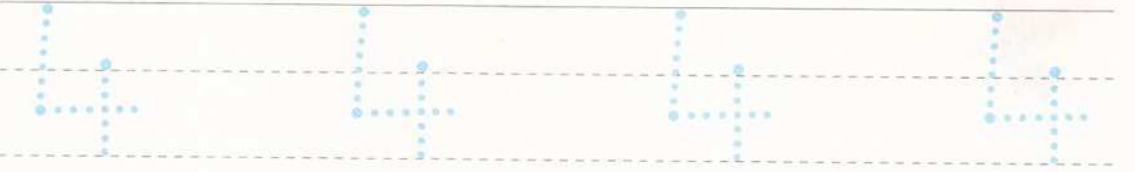
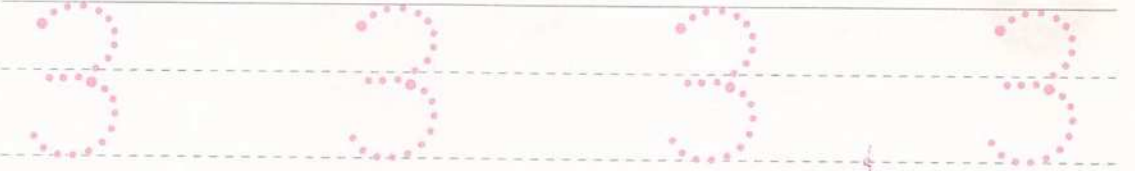
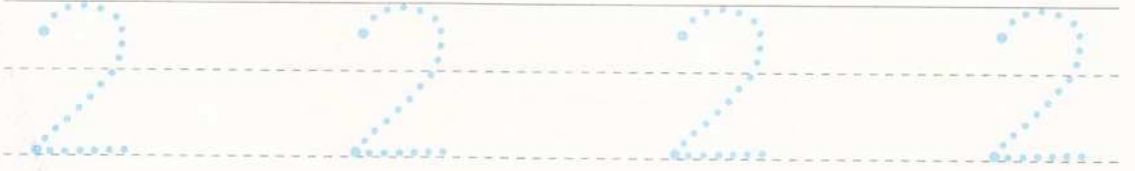
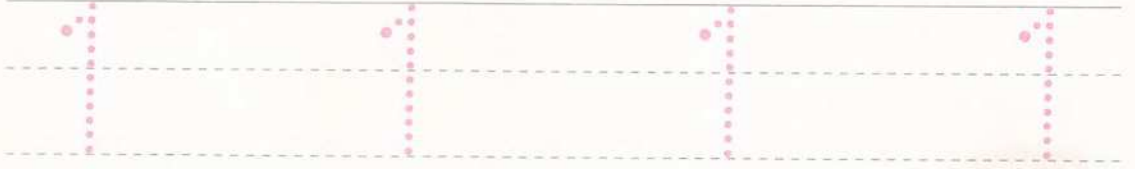
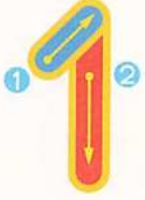

• Ask your child to listen and follow the arrows correctly to write the numbers from 1 to 5.

- اطلب من طفلك أن يستمع ويتتبع الأسهم بشكل صحيح لكتابة الأرقام من ١ إلى ٥.

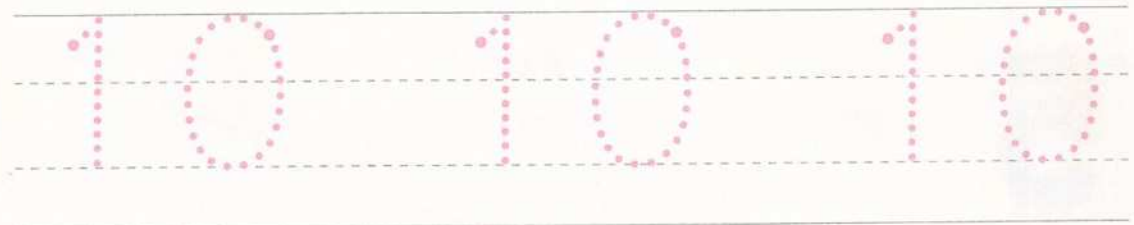
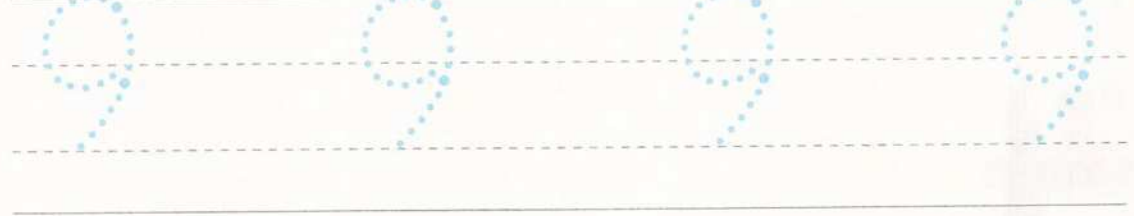
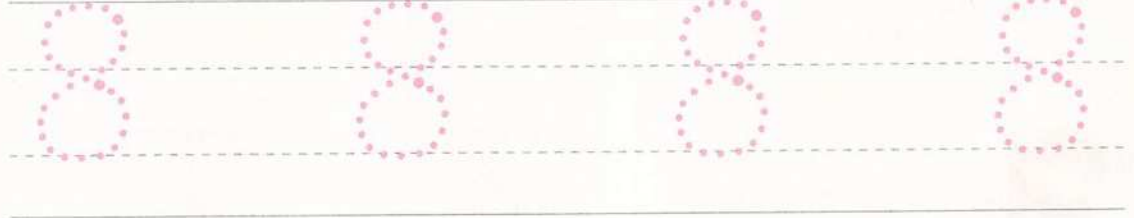
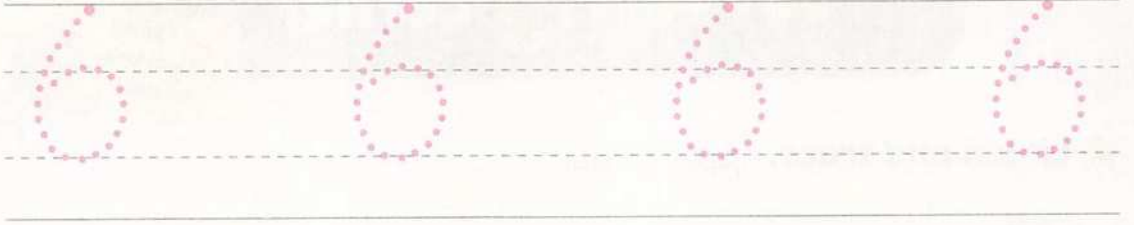

Notes for parents

• Help your child to follow the arrows correctly to write the numbers from 6 to 10

Writing corner

لإتقان مهارة
الكتابة النظرية
كراسة المعاصر
التفاعلية



★ Listen and trace. استمع وتتبع.

one

one

one

one

two

two

two

two

three

three

three

three

four

four

four

four

five

five

five

five

six

six

six

six

seven

seven

seven

seven

eight

eight

eight

eight

nine

nine

nine

nine

ten

ten

ten

ten

Activities on Lessons 4&5



Put a sticker according to your assessment

1 Listen and circle. استمع وضع دائرة.

1. seven

2

6

7

2. five

5

4

8

3. ten

3

10

9

2 Listen and match. استمع وصل.

eight

two

four

2

4

8

3 Listen and tick (✓). استمع وضع علامة (✓).

1.

9

nine

seven

2.

6

eight

six

Notes for parents

1. Ask your child to listen to the words and circle the correct number.

- اطلب من طفلك أن يستمع إلى الكلمات ويضع دائرة حول الرقم الصحيح.

2. Ask your child to listen to the words and match them with the correct number.

- اطلب من طفلك أن يستمع إلى الكلمات ويصل الكلمات بالرقم الصحيح.



3. Ask your child to listen and tick (✓) in front of the correct word.

- اطلب من طفلك أن يستمع ويضع علامة (✓) أمام الكلمة الصحيحة.

4 Trace and Color. تتبع ولون.

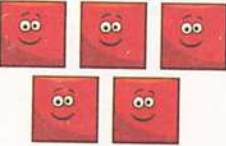
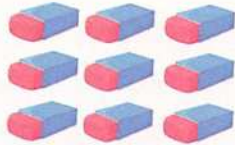

1. 	2. 	3. 
		

5 Listen and circle. استمع وضع دائرة.

1. 	There are <u>five</u> squares. four
2. 	There are <u>eight</u> erasers. nine
3. 	There <u>is</u> one sharpener. are

6 Listen and complete. استمع وأكمل.

seven - are - How

1. 	2. 
There three pens.	There are balloons.

4. Ask your child to trace the dotted words and color the pictures.

5. Ask your child to listen to the sentences and circle the correct answer according to the given pictures.

6. Ask your child to look at the pictures, listen and complete the sentences according to the words in the above box.

Lessons
6&7

- Learn shapes with Busy Bee!
- Learn to count with Busy Bee!



Vocabulary

★ Listen and repeat. استمع وردد.

rectangle مستطيل



square مربع



Shapes
الأشكال

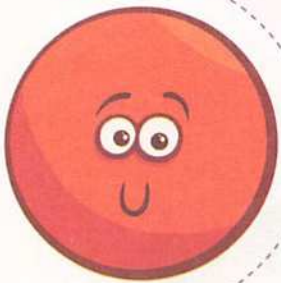

circle دائرة

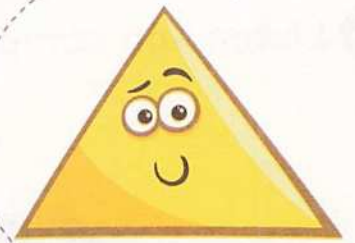

triangle مثلث

Notes for parents

★ Look and circle. انظر وضع دائرة. انظر وضع دائرة.

square

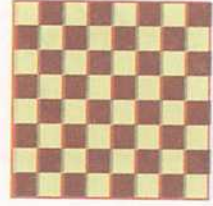

rectangle



triangle

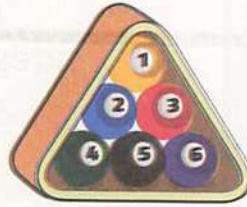
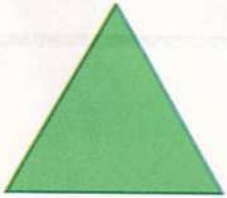

circle



• Help your child to look at the shapes and circle the same according to the given shapes.

- ساعد طفلك أن ينظر الى الأشكال ويضع دائرة حول المشابه طبقًا للأشكال المعطاه.



Activity 1

★ Listen and trace. استمع وتتبع.

1

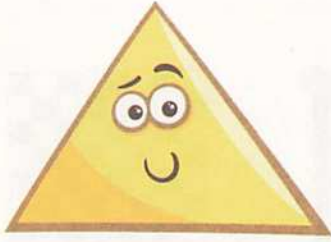

A triangle has **three sides**.
المثلث لديه ثلاث جوانب.



2



A square has **four equal sides**.
المربع لديه 4 جوانب (أضلاع متساوية).



3



A rectangle has **two short sides and two long sides**.
المستطيل لديه ضلعين قصيرين
وضلعين طويلين.



4



A circle is **round**.
الدائرة لها شكل مستدير.



Notes for parents

- Help your child to listen to the sentences and trace the words.
- Help your child identify the shapes and how many sides they have.

- ساعد طفلك ان يستمع إلى الجمل ويتتبع الكلمات.

- ساعد طفلك في التعرف على الأشكال الهندسية ويعرف عدد الأضلاع في كل شكل.

Activity 2

★ Color, count and write. لون، عد واكتب.



★ How many squares  ?

★ How many triangles  ?

★ How many circles  ?

★ How many rectangles  ?

• Help your child color the shapes according to the color codes, count each of them and write the number.

– ساعد طفلك ان يلون الأشكال وفقاً لكوند الألوان ويعد كل منهم على حدة ويكتب العدد.

Writing corner

إتقان مهارة
الكتابة انظر
كراسة المعاصر
التفاعلية



★ Listen and trace. استمع وتتبع.

rectangle



rectangle

rectangle

rectangle

rectangle

circle

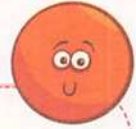

circle

circle

circle

circle

square



square

square

square

square

triangle



triangle

triangle

triangle

triangle

Notes for parents

Activities on Lessons 6 & 7



Put a sticker according to your assessment

1 Listen and circle. استمع وضع دائرة.

1. square



2. 2 rectangles

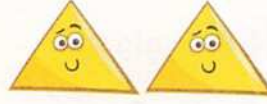
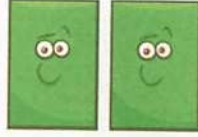

3. 3 triangles

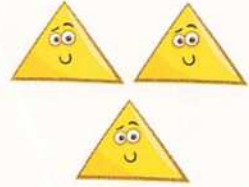
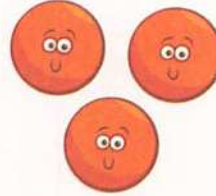

2 Listen and match. استمع وصل.

circle

square

triangle

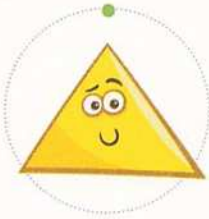

3 Listen and tick (✓). استمع وضع علامة (✓).

1.



triangle

rectangle

2.



circle

square

1. Ask your child to listen to the words and circle the correct picture.

2. Ask your child to listen to the words and match them with the correct pictures.

3. Ask your child to listen and tick (✓) the correct word.

اطلب من طفلك أن يستمع إلى الكلمات ويضع دائرة حول الصورة الصحيحة.

اطلب من طفلك أن يستمع إلى الكلمات ويصل الكلمات بالصورة الصحيحة.

اطلب من طفلك أن يستمع ويضع علامة (✓) أمام الكلمة الصحيحة.

4 Look and circle (✓) or (X). انظر وضع دائرة حول علامة (✓) أو (X).

1.

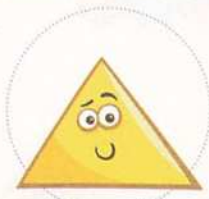

triangle

✓ / X

2.



square

✓ / X

3.



circle

✓ / X

5 Trace and Color. تتبع ولون.

1.

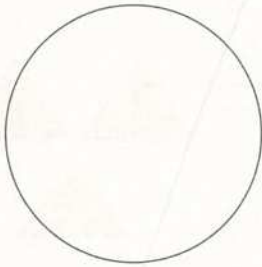

circle

2.

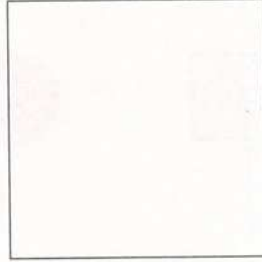

square

3.

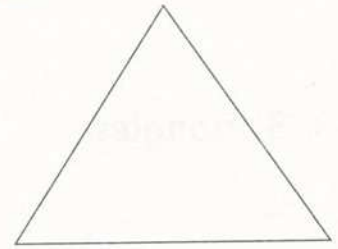

triangle

6 Listen and circle. استمع وضع دائرة.

1.



A square has four equal sides.
circle

2.



A triangle has three sides.
four

3.



A square is round.
circle

4.



A rectangle has four sides.
circles

Notes for parents

4. Ask your child to look and circle (✓) or (X) according to the given word.

- اطلب من طفلك أن ينظر ويضع دائرة حول علامة (✓) أو (X) طبقاً للكلمة المعطاة له.

5. Ask your child to trace the words and color the pictures.

- اطلب من طفلك أن يتتبع الكلمات ويلون الصور.

6. Ask your child to listen to the sentences and circle the correct answer according to the given pictures.

- اطلب من طفلك أن يستمع إلى الجمل ويضع دائرة حول الإجابة الصحيحة طبقاً للصورة المعطاة له.

★ Look, listen and say. انظر ، استمع وقل.



• Help your child describe items in his/her classroom according to shape and color.



Activity ★ Listen, look and Color. استمع ، انظر ولون.

This is my pen. It is blue.

1

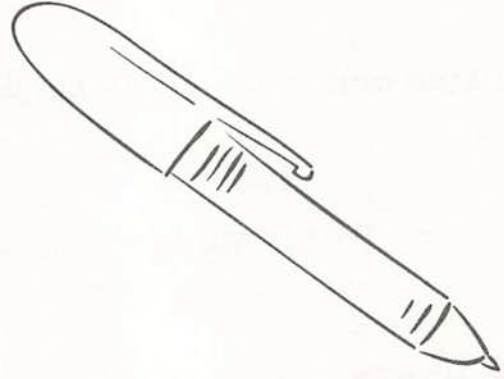

This is a sharpener. It is red.

2

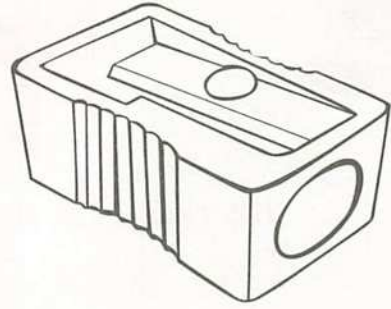
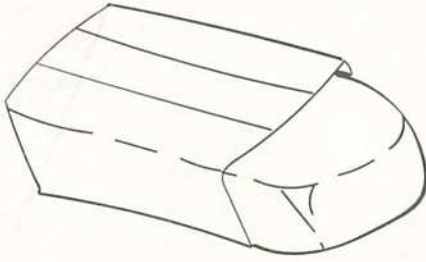

This is an eraser. It is green.

3

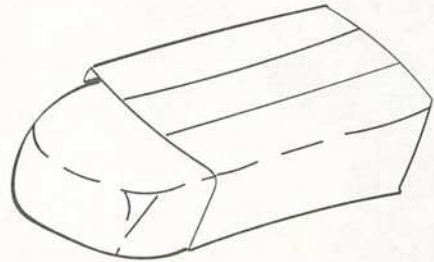

Notes for parents

• Help your child to listen to the sentences, look at pictures and color the right picture.

- ساعد طفلك في الاستماع إلى الجمل والنظر إلى الصور وتلوين الصورة الصحيحة.

★ Look, circle and Color. انظر ، ضع دائرة ولون.

1. The sharpener is a circle.

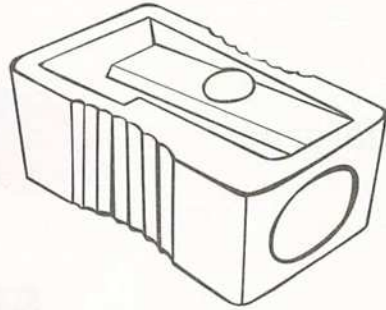

2. The eraser is a triangle.

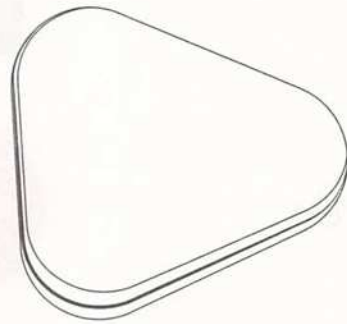
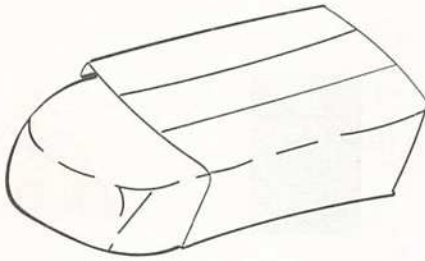

3. The board is a rectangle.

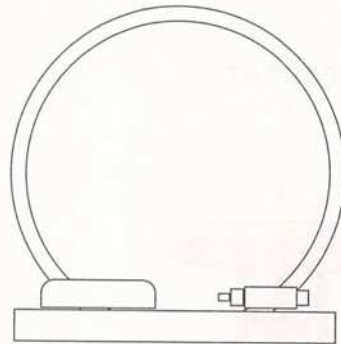
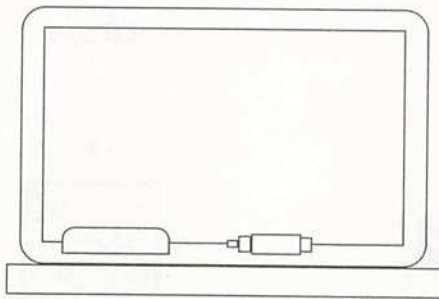

4. The table is a square.

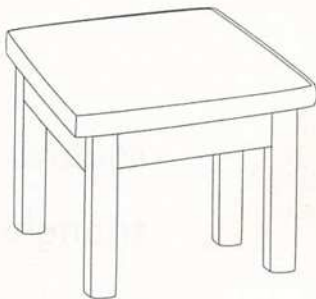

• Help your child look at the pictures and circle the correct picture then color it.

- ساعد طفلك أن ينظر الى الصور و يضع دائرة حول الصورة الصحيحة ثم يلونها.

Activities on Lesson 8



Put a sticker according to your assessment

1 Listen and circle. استمع وضع دائرة.

1. sharpener

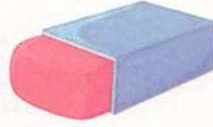

2. square



3. circle

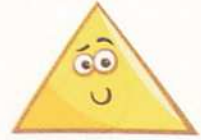

2 Listen and match. استمع وصل.

eraser

square

table

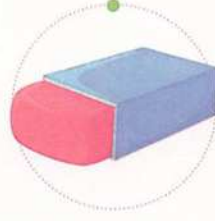

3 Listen and tick (✓). استمع وضع علامة (✓).

1.



table

board

2.



square

triangle

Notes for parents

1. Ask your child to listen to the words and circle the correct picture.

- اطلب من طفلك أن يستمع إلى الكلمات ويضع دائرة حول الصورة الصحيحة.

2. Ask your child to listen to the words and match them with the correct pictures.

- اطلب من طفلك أن يستمع إلى الكلمات ويصل الكلمات بالصور الصحيحة.

3. Ask your child to listen and tick (✓) the correct word.

- اطلب من طفلك أن يستمع ويضع علامة (✓) أمام الكلمة الصحيحة.

- Learn sounds with Busy Bee!
- Learn to write with Busy Bee!



Vocabulary

★ Listen and repeat. استمع وردد.

classroom حجرة الدراسة



mouth فم

Maha مها



M m



Nour نور

N n



nurse ممرضة



nose أنف



pen قلم جاف

• Help your child listen to the words that have / m / and / n / sounds and repeat them.

- ساعد طفلك أن يستمع إلى الكلمات التي تحتوي على الصوتين /m/ و /n/ ويرددها.



Writing

★ Listen and trace. استمع وتتبع.

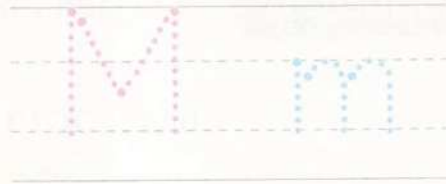

Maha

classroom

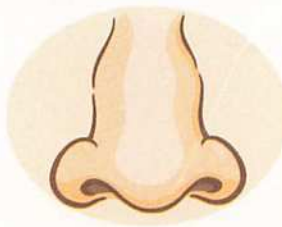
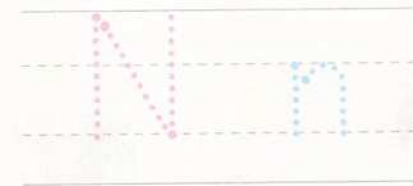

Nour

nose

nurse

Notes for parents

• Help your child listen to and identify the words that have /m/ and /n/ sounds and trace the words.

- ساعد طفلك على الاستماع إلى التعرف على المفردات التي تبدأ بالصوتين /m/ ، /n/ وتتبع الكلمات.

Writing corner

لا تقان مهارة
الكتابة انظر
دراسة المعاصر
التفاعلية



★ Listen and trace. استمع وتتبع.

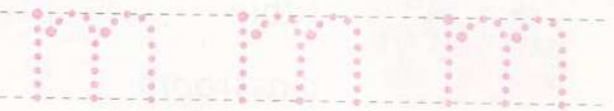
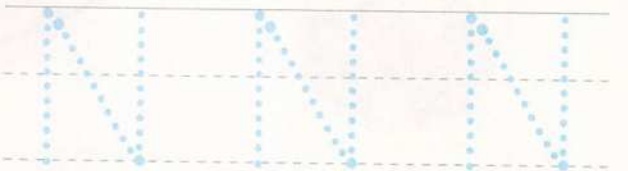
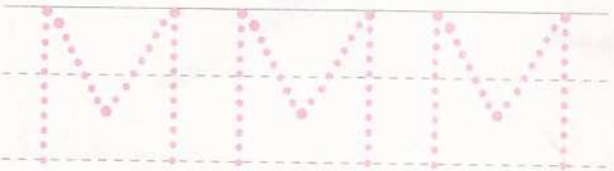
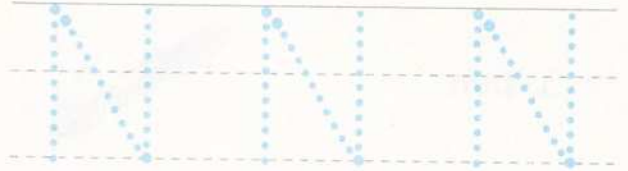
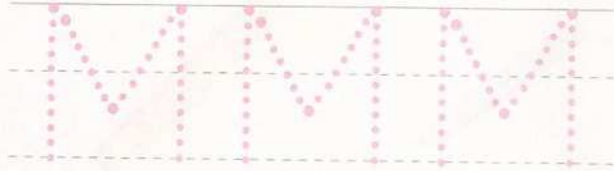
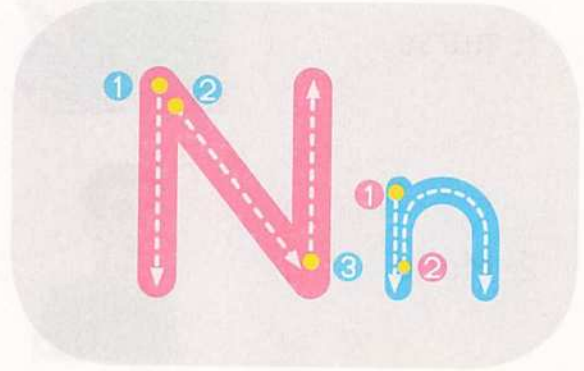
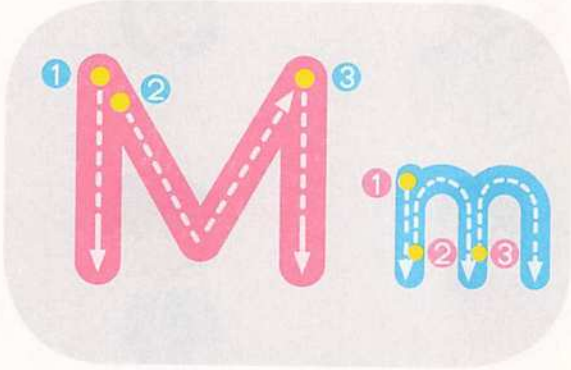

• Ask your child to listen to /m/ and /n/ sounds and trace the letters (Mm) and (Nn).

- اطلب من طفلك أن يستمع إلى الصوتين /m/ , /n/ ويتتبع الحرفين (Mm) , (Nn).

Activities on Lessons 9 & 10



Put a sticker according to your assessment

1 Listen and circle. استمع وضع دائرة.

1. nurse



2. Maha



3. pen



2 Listen and match. استمع وصل.

mouth

pen

classroom

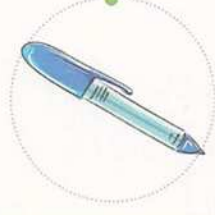

3 Listen and tick (✓). استمع وضع علامة (✓).

1.



Nour

Maha

2.



table

classroom

Notes for parents

1. Ask your child to listen to the words and circle the correct picture.

- اطلب من طفلك أن يستمع إلى الكلمات ويضع دائرة حول الصورة الصحيحة.

2. Ask your child to listen to the words and match them with the correct pictures.

- اطلب من طفلك أن يستمع إلى الكلمات ويصل الكلمات بالصورة الصحيحة.

3. Ask your child to listen and tick (✓) the correct word.

- اطلب من طفلك أن يستمع ويضع علامة (✓) أمام الكلمة الصحيحة.

4 Circle and write. ضع دائرة وأكتب.

1.



n
m
t

classroo -

2.

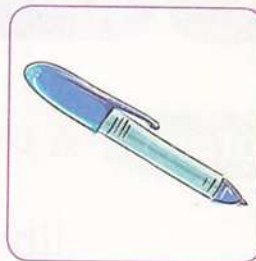

n
b
c

pe -

5 Trace and Color. تتبع ولون.

1.



Maha

2.



Nour

3.

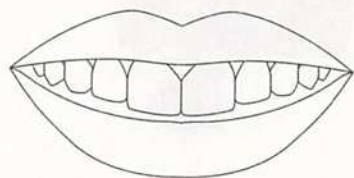

mouth

6 Listen and match. استمع وصل.

1. This is a mouth. ●

2. It is a pen. ●

3. This is a classroom. ●

4. She is a nurse. ●



4. Ask your child to circle the correct letter and write it.

5. Ask your child to trace the words and color the pictures.

6. Ask your child to listen to the sentences and match them with the correct pictures.

- اطلب من طفلك أن يضع دائرة حول الحرف الصحيح ويكتبه.

- اطلب من طفلك أن يتتبع الكلمات ويلون الصور.

- اطلب من طفلك أن يستمع إلى الجمل ويصلها بالصور الصحيحة.

Lessons
11&12

- Connect with Social Studies
- Values

Vocabulary

★ Listen and repeat. استمع وردد.

librarian أمينة مكتبة



teacher معلمة



nurse ممرضة



People who help us
at school

الأشخاص الذين يساعدونا في المدرسة

★ Look, listen and trace. انظر ، استمع وتتبع.



My teacher
helps me write.
تساعدني معلمتي
أن اكتب.



A nurse helps
me feel better.
تساعدني الممرضة
أن اشعر بتحسن.



A librarian
helps me find books.
تساعدني أمينة المكتبة
أن أجد الكتب.

Notes for parents

- Help your child listen to the words and repeat them.
- Help your child look at the pictures, listen to the words and trace the dotted words.
- Help your child learn how to talk about people helping him/her at school.

Sing

My teacher helps
me write my name,

Write my name, write my name.

The teacher helps me write my
name in my book.



The librarian helps
me find books,

Find books, find books.

The librarian helps me
find books in my library.



The nurse helps
me feel better ,

Feel better, feel better.

The nurse helps me feel
better so I go out to play.



★ Listen, look and trace. استمع ، انظر وتتبع.

My friend helps me

1 with my sharpener.

يساعدني صديقي في استخدام برايتي.



My mommy helps me

2 brush my teeth.

تساعدني أمي في غسل اسناني.



My teacher helps me

3 with my math.

تساعدني معلمتي في شرح الرياضيات /
واجب الرياضيات.



My daddy helps me

4 with my bike.

يساعدني أبي في ركوب الدراجة الخاصة بي.



Notes for parents

Activities on Lessons 11 & 12



Put a sticker according to your assessment

1 Listen and circle. استمع وضع دائرة.

1. teacher



2. librarian



3. nurse



2 Listen and match. استمع وصل.

nurse

teacher

librarian



3 Listen and tick (✓). استمع وضع علامة (✓).

1.



librarian

nurse

2.



teacher

nurse

1. Ask your child to listen to the words and circle the correct picture.

- اطلب من طفلك أن يستمع إلى الكلمات ويضع دائرة حول الصورة الصحيحة.

2. Ask your child to listen to the words and match them with the correct pictures.

- اطلب من طفلك أن يستمع إلى الكلمات ويصل الكلمات بالصورة الصحيحة.

3. Ask your child to listen and tick (✓) in front of the correct word.

- اطلب من طفلك أن يستمع ويضع علامة (✓) أمام الكلمة الصحيحة.

4 Listen and circle. استمع وضع دائرة.

1.  A nurse helps me write / feel better.

2.  A teacher / doctor helps me write.

3.  A nurse / librarian helps me find books.

5 Look and circle (✓) or (X). انظر وضع دائرة حول علامة (✓) او (X).

1.  teacher
✓ / X

2.  nurse
✓ / X

3.  librarian
✓ / X

6 Look, listen and complete. انظر، استمع وأكمل.

teacher - books - nurse

1.  My helps me write.

2.  A librarian helps me find

Notes for parents

- Ask your child to listen to the sentences and circle the correct answer according to the given pictures.
اطلب من طفلك أن يستمع إلى الجمل ويضع دائرة حول الإجابة الصحيحة طبقاً للصور المعطاة.
- Ask your child to look at the picture and circle (✓) or (X) according to the given words.
اطلب من طفلك أن ينظر إلى الصور ويضع دائرة حول علامة (✓) أو (X) طبقاً للكلمات المعطاة.
- Ask your child to look at the pictures, listen and complete the sentences according to the words in the above box.
اطلب من طفلك أن ينظر إلى الصور ويستمع إلى الجمل ثم يكملها طبقاً للكلمات التي في الصندوق أعلاه.

Dina gets ready for school !

دينا تستعد للمدرسة !

We can help each other !

نستطيع مساعدة بعضنا البعض !



★ Listen, look and role-play : (with the masks ).

استمع، انظر وتبادل الأدوار : (باستخدام الأقنعة).

1

Adam, can you help me get ready for school tomorrow ?

آدم، هل يمكنك مساعدتي أن استعد للمدرسة غدًا ؟

Yes, of course !

نعم، بالطبع !



2

I want an eraser, a sharpener, some pens and some pencils.

أنا أريد أستيكة، براية وبعض الأقلام الجاف وبعض من الأقلام الرصاص.

Which eraser do you want ?

أي أستيكة تريدين ؟



The yellow eraser. It's a triangle.

الأستيكة ذات اللون الأصفر. إنها مثلثة الشكل.

Notes for parents

- Help your child listen to the scenes of the story, and let him/her say what he/she listens to correctly, then as him/her to role-play it with his/her colleagues.

– ساعد طفلك في الاستماع إلى مشاهد القصة ودعه يقول ما يسمعه بطريقة صحيحة ، ثم اطلب منه أن يتبادل الأدوار مع زملائه.

3 The green, square sharpener.

البراية مربعة الشكل خضراء اللون.

Which sharpener do you want ?
أى براءة تريدان ؟



4 I want two yellow pencils, please.

أنا أريد قلمين رصاص لونهما اصفر ، من فضلك.

Which pencils do you want ?

أى أقلام رصاص تريدان ؟



Which pens do you want ?

أى أقلام جاف تريدين ؟

I want one pen - my blue pen.

أريد قلم جاف واحد - قلمي الجاف الأزرق.

5



I can't see your blue pen.

انا لا أرى قلمك الجاف الأزرق.

Can you help ?
Can you see Dina's blue pen ?

هل تستطيع إن تساعدني ؟

هل تستطيع أن ترى قلم دينا الازرق ؟

6



7

Here it is! هاهو!

Look! انظروا!



Thank you, Adam! Thank you,
Busy Bee!

شكرا لك يا آدم! شكرا لك أيتها النحلة النشيطة!



Activity



Listen and Color. استمع ولون.



I want two yellow pencils, please.

• Help your child listen to the sentence and color the pencils according to the given sentence.

– ساعد طفلك في الاستماع إلى الجملة وتلوين الأقلام الرصاص طبقاً للجملة المعطاة.

Retell



★ **Make a story.** قم بعمل قصة.

Draw

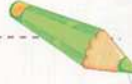

Notes for parents

Activities on Lesson 13



Put a sticker according to your assessment

1 Listen and circle. استمع وضع دائرة.

1. red square



2. green triangle



3. blue circle



2 Listen and match. استمع وصل.

round sharpener

red rectangle

blue triangle

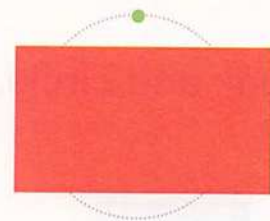
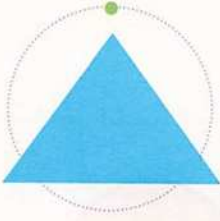

3 Listen and tick (✓). استمع وضع علامة (✓).

1.



green

blue

2.



pencil

ruler

1. Ask your child to listen to the words and circle the correct picture.

- اطلب من طفلك أن يستمع إلى الكلمات ويضع دائرة حول الصورة الصحيحة.

2. Ask your child to listen to the words and match them with the correct pictures.

- اطلب من طفلك أن يستمع إلى الكلمات ويصل الكلمات بالصورة الصحيحة.

3. Ask your child to listen and tick (✓) the correct word.

- اطلب من طفلك أن يستمع ويضع علامة (✓) أمام الكلمة الصحيحة.

4 Trace and Color. تتبع ولون.

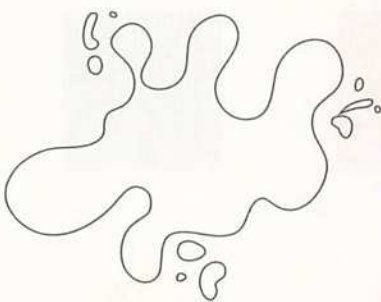
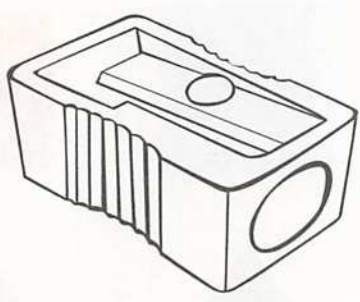
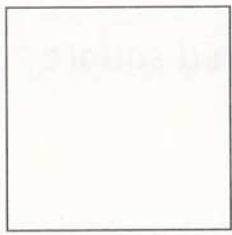
1.	2.	3.
		
blue	sharpener	square

5 Trace and circle. تتبع وضع دائرة.

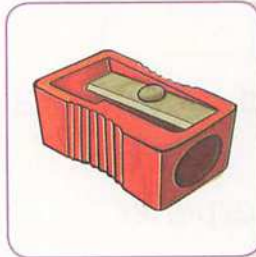
1.	2.
	
c s y yellow	c s r sharpener

6 Look and circle. انظر وضع دائرة.

1.	2.	3.
		
square triangle	school classroom	circle rectangle

Notes for parents

4. Ask your child to trace the words and color the pictures.

5. Ask your child to trace the dotted letter and circle it.

6. Ask your child to look at each picture and circle the correct word.

- اطلب من طفلك أن يتتبع الكلمات ويلون الصور.

- اطلب من طفلك أن يتتبع الحرف المكتوب على شكل نقاط ويضع دائرة حول الحرف الصحيح.

- اطلب من طفلك أن ينظر إلى كل صورة ويضع دائرة حول الكلمة الصحيحة.



ارشادات اللعبة

Mo Game

Start →

اطلب من طفلك ان يبحث عن الصور
فى الكروت ويضع كل صورة على الظل
المناسب لها.

Level 1 ★

اطلب من طفلك ان يستمع الي الكلمات
ويبحث عنها فى الكروت ويضع كل كلمة
على الكلمة المناسبة لها.

Level 2 ★

اطلب من طفلك ان يستمع الي الكلمات
ويبحث عن حروف كل كلمة فى الكروت
ويضعها لتكون الكلمة.

Level 3 ★

Level 1

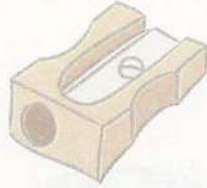
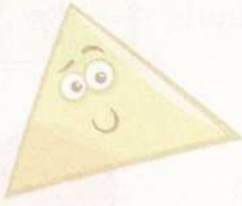

Level 2

nurse

table

pencil

Level 3



pen



board

1

2

3

1

2

3

4

5

* استخدم كروت اللعبة من كراسة المعاصر التفاعلية.

* يحصل الطفل علي مبلغ 50 Mo kids مكافاة مع كل اجابة صحيحة.

* يمكن للطفل ان يلعب وحدة أو يشارك زميل أو أكثر فى اللعبة. والفائز هو من يحصل علي أكثر نقود.

تنويه

Review on UNIT 2

Classroom items

pencil 

pen 

eraser 

sharpener 

board 

shapes

triangle 

square 

rectangle 

circle 

Vocabulary

In my classroom

Language

Phonics



• There is one pencil.

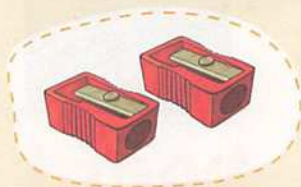

• There are two sharpeners.

Mm



mouth



Maha

Nn



nurse



nose



Nour

Notes for parents

Activities on Unit 2



Put a sticker according to your assessment

1 Listen and circle. استمع وضع دائرة.

1. board



2. triangle

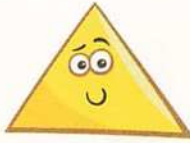

3. eight



2 Listen and match. استمع وصل.

table

five

circle



3 Listen and tick (✓). استمع وضع علامة (✓).

1.



board

table

2.



teacher

nurse

1. Ask your child to listen to the words and circle the correct picture.

2. Ask your child to listen to the words and match them with the correct pictures.

3. Ask your child to listen and tick (✓) in front of the correct word.

Activities on Unit 2

4 Look and circle (✓) or (X). انظر وضع دائرة حول علامة (✓) أو (X).

1.



eraser

✓ / X

2.



nine

✓ / X

3.

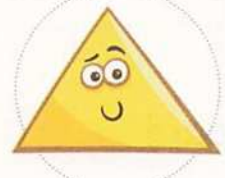

triangle

✓ / X

5 Trace and Color. تتبع ولون.

1.

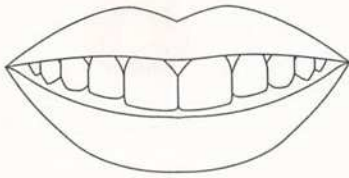

mouth

2.



Maha

3.



teacher

6 Trace and circle. تتبع وضع دائرة.

1.

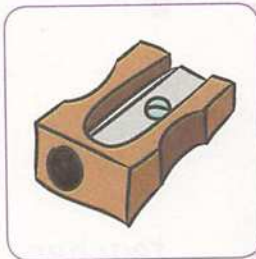

sharpener

c

s

r

2.

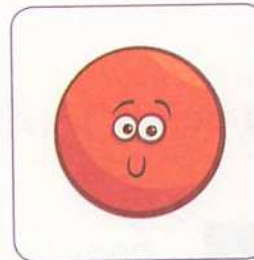

circle

c

s

r

Notes for parents

4. Ask your child to look and circle (✓) or (X) according to the given word.

- اطلب من طفلك ان ينظر ويضع دائرة حول علامة (✓) أو (X) طبقا للكلمة المعطاة له.

5. Ask your child to trace the words and color the pictures.

- اطلب من طفلك ان يتتبع الكلمات ويلون الصور.

6. Ask your child to trace the dotted letter and circle it.

- اطلب من طفلك ان يتتبع الحرف المكتوب على شكل نقاط ويضع دائرة حوله.

THEME

2

The world around me



Unit
3

Our Animals

حيواناتنا

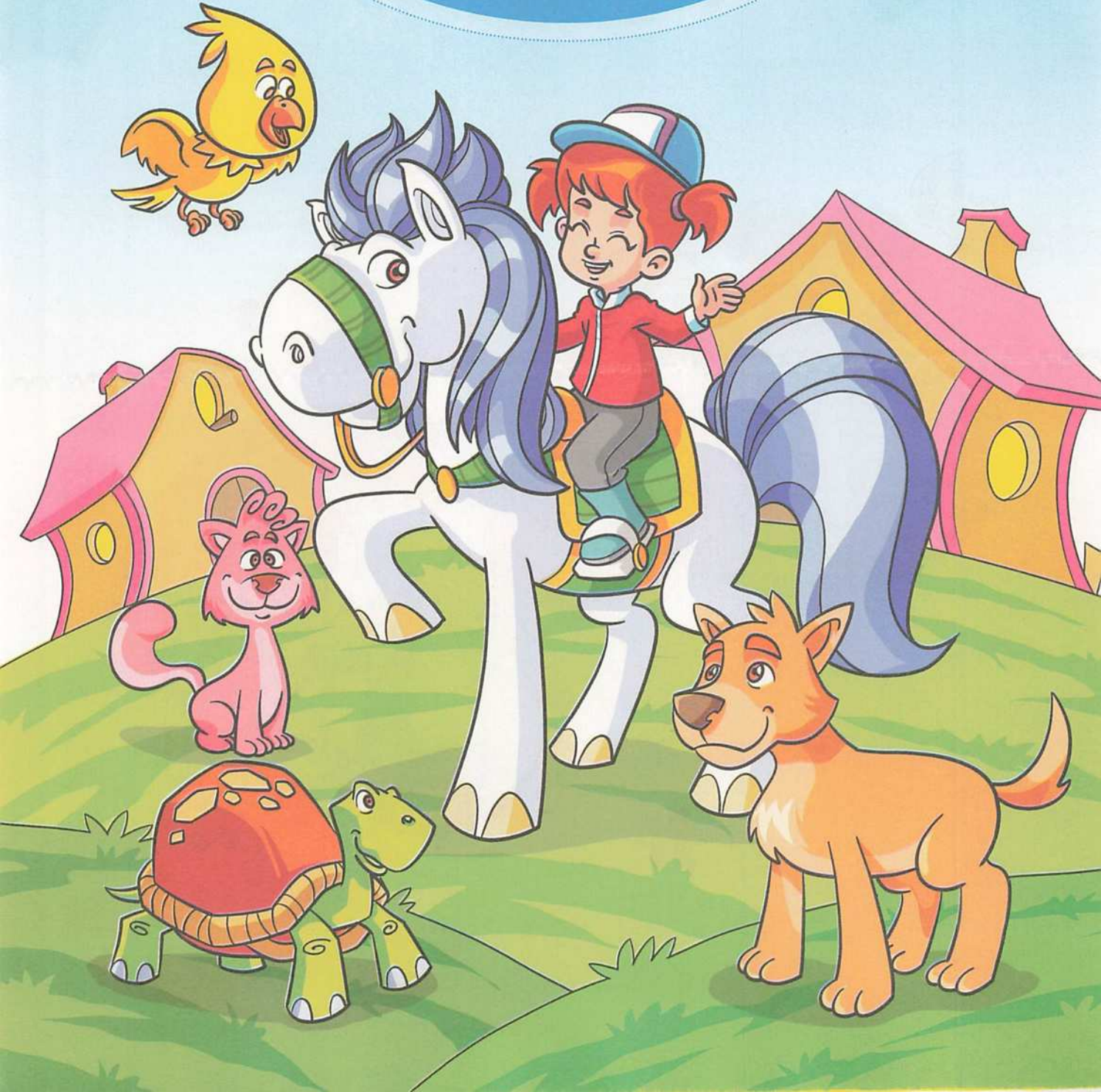

Unit 3 Objectives



Lessons 1 & 2

Objectives :

- To identify domestic, farm and other regionally familiar animals
- أن يتعرف على حيوانات المزرعة التي تربي في المنزل وحيوانات أليفة أخرى

Vocabulary :

- sheep, rabbit, frog, fish, horse, camel, cat
- خروف/خراف، أرنب، ضفدع، سمك / سمكة، حصان، جمل، قطة

Lessons 3 & 4

Objectives :

- To determine some of animals habitats : land / water
- أن يحدد (بيئات) الحيوانات : اليابسة/الماء
- To Know which animals live on land and which in water
- أن يعرف أي الحيوانات تعيش على اليابسة وأي في الماء

Language :

- Where do camels live ?
- أين تعيش الجمال ؟
- Camels live on land.
- الجمال تعيش على اليابسة.

Lessons 5 & 6

Objectives :

- To differentiate between living and non-living things
- أن يفرق بين الكائنات الحية والغير حية

Language :

- Living things eat, breathe and grow.
- الكائنات الحية تأكل، تتنفس وتنمو.
- Non-living things don't eat, don't breathe, don't grow.
- الكائنات الغير حية لا تأكل، لا تتنفس ولا تنمو.

Lessons 7 & 8

Objectives :

- To identify your favorite animal
- To read about looking after animals

- 1- أن تتعرف على حيوانك المفضل
- 2- أن يقرأ عن كيفية الاعتناء بالحيوانات

Lessons 9 & 10

Objectives :

- To recognize and produce the letters sounds /p/ and /r/
1- أن يتعرف على نطق أصوات /p/ و /r/
- To find words with /p/ and /r/
2- أن يجد كلمات بصوت /p/ و /r/
- To trace and copy letters (P,p) and (R,r)
3- أن يتتبع وينسخ حرف (P,p) و (R,r)

Vocabulary :

- panda, Pyramids, playground, pen, Peter, red, sharpener, run, rabbit, Reem
حيوان الباندا، الاهرامات، ملعب ، قلم جاف ، بيتر ، لون احمر، برائة، يجرى، أرنب ، ريم

Lessons 11 & 12

Objectives :

- To recognize the human and animal lifecycles
1- أن يتعرف على دورة الحياة الخاصة بالإنسان والحيوان
- To identify the lifecycle of an animal (a frog)
2- أن يتعرف على دورة الحياة الخاصة بالحيوان (الضفدع)

Vocabulary :

- baby, child, teenager, adult, eggs, baby frog , adult frog
رضيع، طفل، مراهق، بالغ، بيض ، ضفدع صغير ، ضفدع بالغ

Lesson 13

Objectives :

- To revise the stages of life for animals, especially a frog
- أن يراجع دورة الحياة الخاصة بالحيوانات بالأخص الضفدع

Vocabulary :

- baby, adult, frog, living thing , water, food
رضيع ، بالغ ، ضفدع ، الكائن الحي ، ماء، طعام

Lessons
1&2

• Vocabulary



Vocabulary

★ Listen and repeat. استمع وردد.

sheep خروف



rabbit أرنب



cat قطة



frog ضفدع



animals
حيوانات



camel جمل



horse حصان



fish سمكة

Notes for parents

★ Listen, look and role-play : (with the masks ).



What can you see?

ماذا تستطيع ان تربي؟



I can see a cat.

استطيع ان أربي قطة .



I can see a camel.

استطيع ان أربي جمل .



I can see a fish.

استطيع ان أربي سمكة .

استمع، انظر وتبادل الأدوار : (باستخدام الأقنعة).

I can see a rabbit.

استطيع ان أربي ارنب .



I can see a frog.

استطيع ان أربي ضفدع .



I can see a sheep.

استطيع ان أربي خروف .



I can see a horse.

استطيع ان أربي حصان .



• Help your child listen to the dialogue and let him/ her say what he/ she listens to correctly, then ask him/ her to role-play it with his/ her colleagues.

- ساعد طفلك في الاستماع إلى المحادثة ودعه يقول ما يسمعه بطريقة صحيحة ثم اطلب منه أن يتبادل الأدوار مع زملائه باستخدام الأقنعة.

Writing corner

لإتقان مهارة
الكتابة انظر
كراسة المعاصر
التفاعلية



★ Listen and trace. اسلمع وتتبع.

sheep



sheep

sheep

sheep

rabbit



rabbit

rabbit

rabbit

frog



frog

frog

frog

cat



cat

cat

cat

camel



camel

camel

camel

fish



fish

fish

fish

horse



horse

horse

horse

Notes for parents

Activities on Lessons 1&2



Put a sticker according to your assessment

1 Listen and circle. استمع وضع دائره.

1. horse



2. fish



3. frog



2 Listen and match. استمع وصل.

sheep

cat

rabbit



3 Listen and tick (✓). استمع وضع علامة (✓).

1.



frog

fish

2.



horse

sheep

1. Ask your child to listen to the words and circle the correct picture.

- اطلب من طفلك أن يستمع إلى الكلمات ويضع دائرة حول الصورة الصحيحة.

2. Ask your child to listen to the words and match them with the correct pictures.

- اطلب من طفلك أن يستمع إلى الكلمات ويصل الكلمات بالصورة الصحيحة.

3. Ask your child to listen and tick (✓) in front of the correct word.

- اطلب من طفلك أن يستمع ويضع علامة (✓) أمام الكلمة الصحيحة.

Activities on Lessons 1&2

4 Look and circle (✓) or (X). انظر وضع دائرة حول علامة (✓) او (X).

1.



horse

✓ / X

2.



camel

✓ / X

3.



frog

✓ / X

5 Trace and Color. تتبع ولون.

1.



rabbit

2.



cat

3.

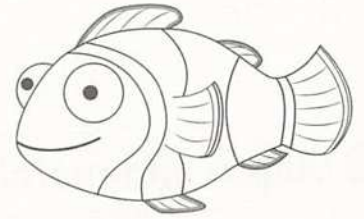

fish

6 Trace and circle. تتبع وضع دائرة.

1.



sheep

s

m

d

2.

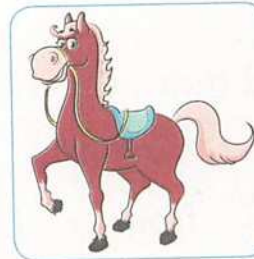

horse

m

h

s

Notes for parents

4. Ask your child to look and circle (✓) or (X) according to the given word.

- اطلب من طفلك أن ينظر ويضع دائرة حول علامة (✓) أو (X) وفقاً للكلمة المعطاة له.

5. Ask your child to trace the words and color the pictures.

- اطلب من طفلك أن يتتبع الكلمات ويلون الصور.

6. Ask your child to trace the dotted letters and circle the correct letter.

- اطلب من طفلك أن يتتبع الحروف المكتوبة علي شكل نقاط ويضع دائرة حول الحرف الصحيح.

Lessons
3&4

- Listening and reading
- Connect with Geography

Vocabulary

★ Listen and repeat. استمع وردد.



land يابس (أرض)



water ماء

Language

★ Where do camels live ?

• أين تعيش الجمال ؟



Camels live on land. الجمال تعيش على اليابس.



Fish live in water. السمك يعيش في الماء.

- Help your child listen to the words and repeat them.
- Help your child know where animals live.

- ساعد طفلك أن يستمع إلى الكلمات ويردها.
- ساعد طفلك أن يعرف أين تعيش الحيوانات.

Activity 1

★ Trace, cut and stick. تتبع، قص والصق.

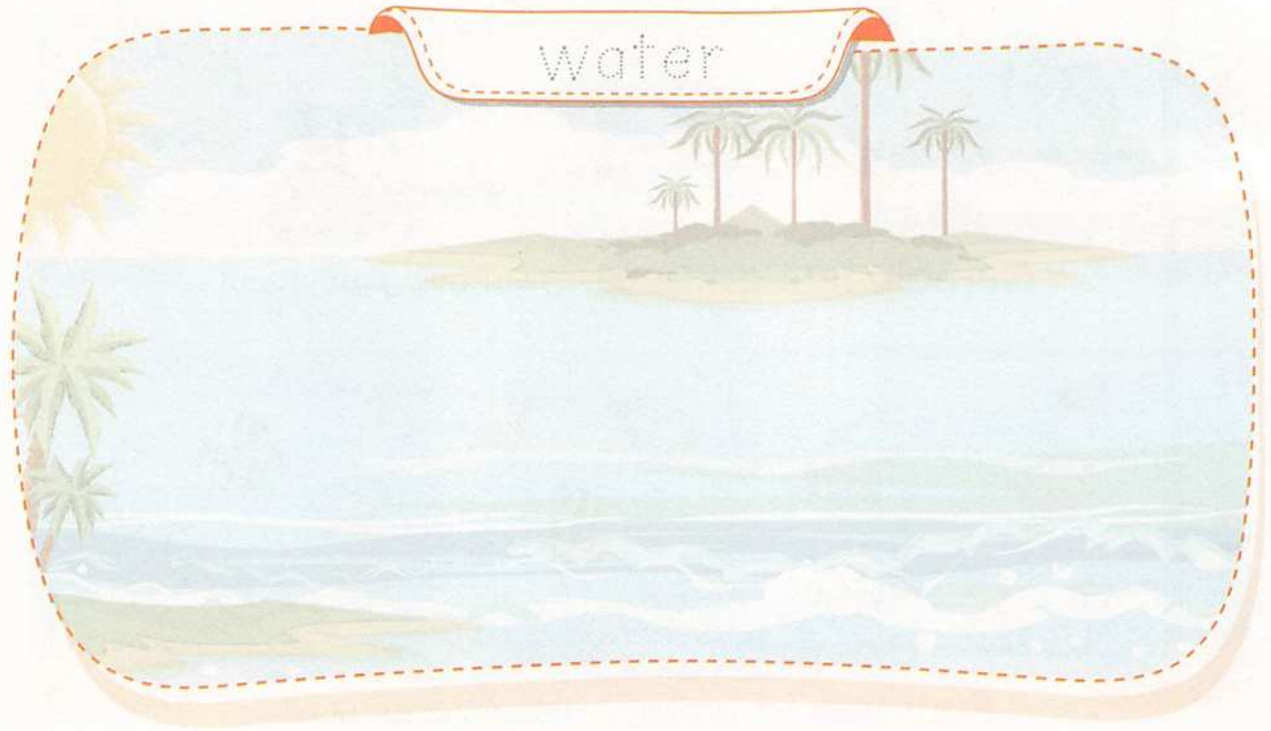

Notes for parents

1. Help your child trace the dotted words, cut the pictures of land / water from El-Moasser Interactive Notebook and stick them in their right place.

Activity 2

★ Look and match. انظر وصل.



2. Help your child to look and match each animal to its habitat.

- ساعد طفلك أن ينظر و يصل كل حيوان بموطنه / بيئته.

Sing



Do you know where camels live,
camels live, camels live?
Do you know where camels live,
camels live, camels live?
Yes, I know where camels live,
camels live, camels live.
Yes, I know where camels live,
camels live, camels live.
They live on **LAND**.



Do you know where fish live, fish
live, fish live?
Do you know where fish live, fish
live, fish live?
Yes, I know where fish live,
fish live, fish live.
Yes, I know where fish live,
fish live, fish live.
They live in **WATER**.



Notes for parents

Activities on Lessons 3&4



Put a sticker according to your assessment

1 Listen and circle. استمع وضع دائرة.

1. land



2. water



3. sheep

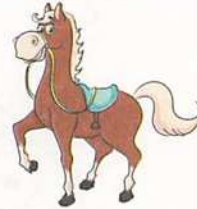

2 Listen and match. استمع وصل.

horse

frog

fish



3 Listen and tick (✓). استمع وضع علامة (✓).

1.



land

water

2.



rabbit

fish

1. Ask your child to listen to the words and circle the correct picture.

- اطلب من طفلك أن يستمع إلى الكلمات ويضع دائرة حول الصورة الصحيحة.

2. Ask your child to listen to the words and match them with the correct pictures.

- اطلب من طفلك أن يستمع إلى الكلمات ويصل الكلمات بالصورة الصحيحة.

3. Ask your child to listen and tick (✓) the correct word.

- اطلب من طفلك أن يستمع ويضع علامة (✓) أمام الكلمة الصحيحة.

4 Look and circle (✓) or (X). انظر وضع دائرة حول علامة (✓) أو (X).

1.



fish

✓ / X

2.



water

✓ / X

3.



horse

✓ / X

5 Trace and Color. تتبع ولون.

1.

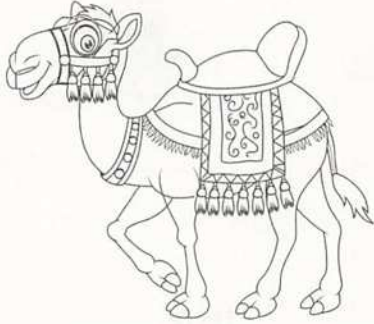

camel

2.

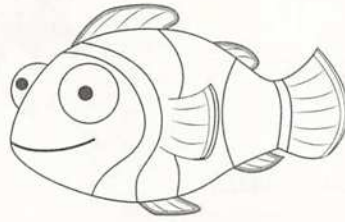

fish

3.

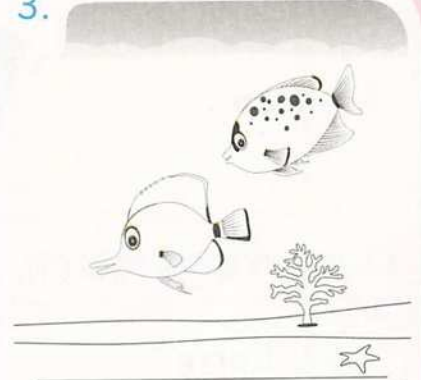

water

6 Trace and circle. تتبع وضع دائرة.

1.



cat

k

s

c

2.



water

v

w

y

Notes for parents

4. Ask your child to look and circle (✓) or (X) according to the given word.

- اطلب من طفلك أن ينظر ويضع دائرة حول علامة (✓) أو (X) طبقاً للكلمة المعطاة له.

5. Ask your child to trace the words and color the pictures.

- اطلب من طفلك أن يتتبع الكلمات ويلون الصور.

6. Ask your child to trace the dotted letter and circle the correct letter.

- اطلب من طفلك أن يتتبع الحرف المكتوب على شكل نقاط ويضع دائرة حول الحرف الصحيح.

7 Listen and circle. استمع وضع دائرة.

1.



Rabbits live on land
water

2.



Fish live in water
land

3.



Cats live on land.
Fish

4.



Camels live on land
water

8 Listen and match. استمع وصل

rabbit

camel

frog

fish



9 Trace. تتبع

Sheep live on land.

Sheep live on land.

7. Ask your child to listen to the sentences and circle the correct answer according to the given pictures.

8. Ask your child to listen to the words and match them with the correct pictures.

9. Ask your child to trace the given sentence.

Lessons
5&6

- The living world
- Language use

Vocabulary

★ **Look and listen.** انظر واستمع.

تنمو grow



تأكل eat



تتنفس breathe



الكائنات الحية living things

الكائنات غير الحية non-living things



لا تتنفس don't breathe



لا تأكل don't eat



لا تنمو don't grow

Notes for parents

• Help your child differentiate between living things and non-living things.

- ساعد طفلك أن يفرق بين الكائنات الحية والكائنات غير الحية.

• Help your child look at the pictures and listen to the words.

- ساعد طفلك أن ينظر إلى الصور و يستمع إلى الكلمات.

Activity 1

★ Look, listen and trace. انظر، استمع وتتبع.

Living things eat.

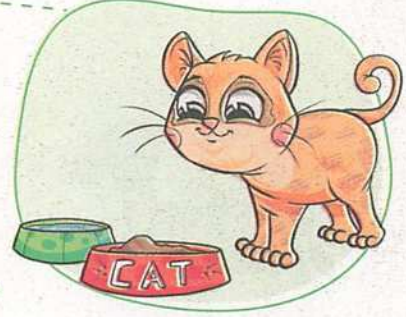

Living things grow.

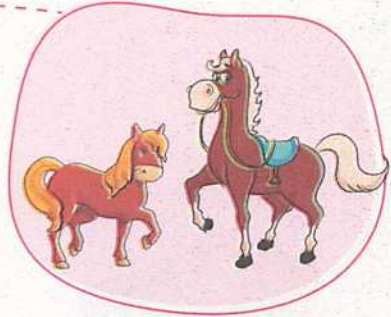

Living things breathe.

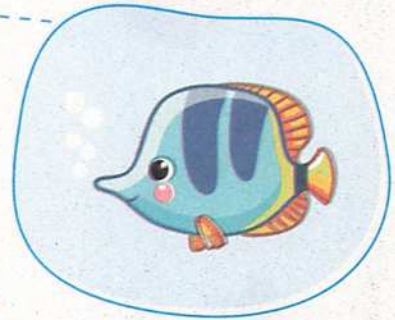

Non-living things don't eat.



1. Help your child look at the pictures, listen to the sentences and trace the dotted words.

– ساعد طفلك أن ينظر إلى الصور، يستمع إلى الجمل ويتتبع الكلمات المكتوبة على شكل نقاط.

Activity 2

★ Color the circle of living things in red and non-living things in green.
لون دائرة الكائنات الحية باللون الاحمر والكائنات الغير حية باللون الأخضر.

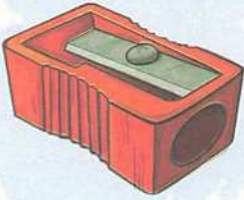

Notes for parents

Activity 3

★ Look and stick. انظر والصق.

★ living things



★ Non-Living things

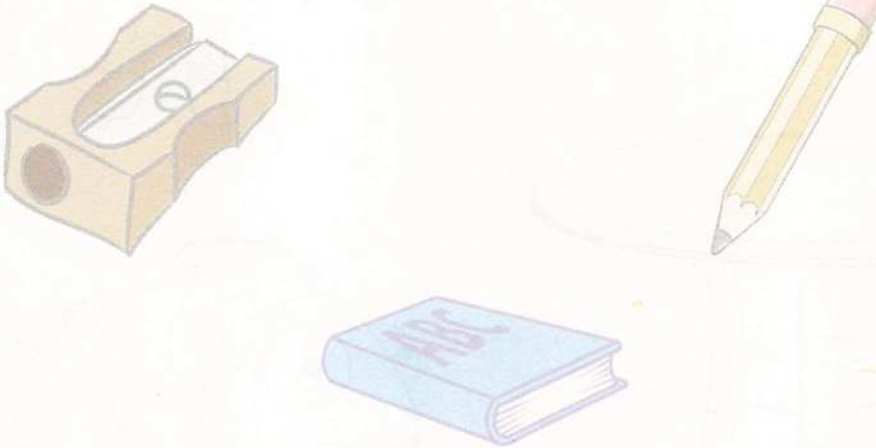

3. Help your child stick pictures of living and non-living things in their right place to classify different types of things.

- ساعد طفلك أن يلصق صور للكائنات الحية و الغير حية في مكانها الصحيح ليعرف الفرق بين الكائنات الحية والغير حية.

★ Activity 4

★ Color the living things. لون الكائنات الحية.

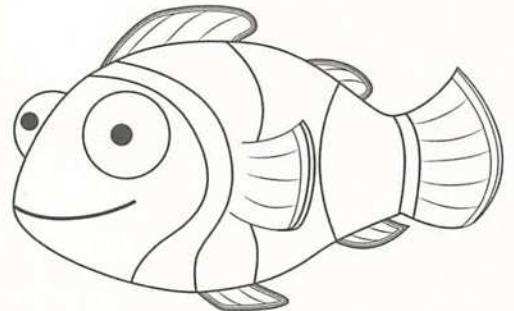
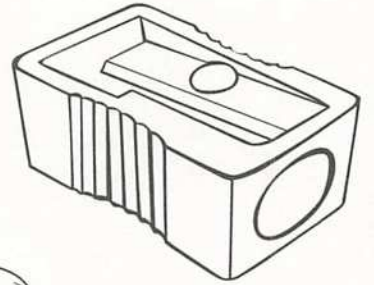
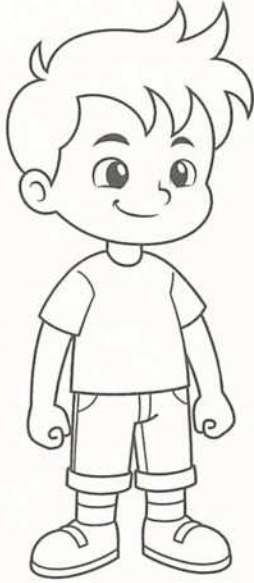

Notes for parents

Activities on Lessons 5&6



Put a sticker according to your assessment

1 Listen and circle. استمع وضع دائره.

1. non-living thing



2. cat



3. eat



2 Listen and match. استمع وصل.

living things

sheep

pencil

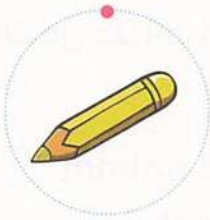

3 Listen and tick (✓). استمع وضع علامة (✓).

1.



living things

non-living things

2.



grow

don't grow

1. Ask your child to listen to the words and circle the correct picture.

- اطلب من طفلك أن يستمع إلى الكلمات ويضع دائرة حول الصورة الصحيحة.

2. Ask your child to listen to the words and match them with the correct pictures.

- اطلب من طفلك أن يستمع إلى الكلمات ويصل الكلمات بالصورة الصحيحة.

3. Ask your child to listen and tick (✓) the correct word.

- اطلب من طفلك أن يستمع ويضع علامة (✓) أمام الكلمة الصحيحة.

Lessons
7&8

- Listening and speaking
- Values



Vocabulary

★ Listen and repeat. استمع وردد.

love يحب

look after يعتني بـ



panda دُب الباندا



Language

★ Talking about your favorite animal. التحدث عن حيوانك المفضل.

What's your favorite animal?
ما هو حيوانك المفضل؟



My favorite animal is the cat.
حيواني المفضل هي القطه.



Notes for parents

- Help your child listen to the words and repeat them.
- Help your child ask and answer questions about his/ her favorite animals.

- ساعد طفلك أن يستمع إلى الكلمات ويرددها.

- ساعد طفلك أن يسأل ويجيب اسئله عن حيوانه/حيوانها المفضل.

★ Look and listen. انظر واستمع.



Mango is my cat.
مانجو قطتي.



She eats.
هي تأكل.



She grows.
هي تنمو.



I love Mango!
أنا أحب مانجو!



I look after Mango.
أنا أعتني بمانجو.

★ Activity 1 ★ Look, listen and tick (✓). انظر، استمع وضع علامة (✓).



Mango eats.



Mango doesn't grow.



I look after Mango.



Mango doesn't eat.



Mango grows.



I don't look after Mango.

• Help your child look at the pictures and listen to the sentences.
1. Help your child look, listen and tick (✓) the suitable sentence.

• ساعد طفلك في النظر إلى الصور والاستماع إلى الجمل.
• ساعد طفلك أن ينظر، يستمع ويضع علامة (✓) للجملة المناسبة.

Sing

There is a girl who has a cat
Has a cat, has a cat.



There is a girl who has a cat
And its name is Mango.



There is a boy who has a horse
Has a horse, has a horse.



There is a boy who has a horse
And its name is Billy.



Notes for parents

• Sing with your child.

Activities on Lessons 7 & 8



Put a sticker according to your assessment

1 Listen and circle. استمع وضع دائره.

1. animal



2. camel



3. cat



2 Listen and match. استمع وصل.

fish

frog

horse



3 Listen and tick (✓). استمع وضع علامة (✓).

1.



eats

doesn't eat

2.



fish

panda

1. Ask your child to listen to the words and circle the correct picture.

- اطلب من طفلك أن يستمع إلى الكلمات ويضع دائرة حول الصورة الصحيحة.

2. Ask your child to listen to the words and match them with the correct pictures.

- اطلب من طفلك أن يستمع إلى الكلمات ويصل الكلمات بالصورة الصحيحة.

3. Ask your child to listen and tick (✓) in front of the correct word.

- اطلب من طفلك أن يستمع ويضع علامة (✓) أمام الكلمة الصحيحة.

4 Look and circle (✓) or (X). انظر وضع دائرة حول (✓) او (X).

1.



cat

✓ / X

2.



sheep

✓ / X

3.



love

✓ / X

5 Look and complete. انظر وأكمل.

horse - panda - camel - fish

1.



My favorite animal is the

2.



It's a

3.



It's a

4.



My favorite animal is the

6 Trace. تتبع.

Mango is my cat.

Mango is my cat.

Notes for parents

4. Ask your child to look and circle (✓) or (X) according to the given word.

اطلب من طفلك أن ينظر ويضع دائرة حول (✓) أو (X) وفقاً للكلمة المعطاة له.

5. Ask your child to look at the pictures, and complete the sentences according to the words in the above box.

اطلب من طفلك أن ينظر الى الصور ويكمل الجمل طبقاً للكلمات التي في الصندوق اعلاه.

6. Ask your child to trace the given sentence.

اطلب من طفلك أن يتتبع الجملة المعطاة.

Lessons
9&10

- Learn sounds with Busy Bee!
- Learn to write with Busy Bee!



Phonics

★ Listen and repeat. استمع وردد.

Pyramids اهرامات

panda دُب الباندا



playground ملعب



pan مقلاة



P p

Peter بيتر



red لون احمر

R r



Reem ريم

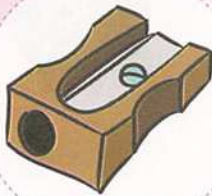

sharpener براية



run يجري



rabbit ارنب

• Help your child listen to the words that have the /p/ and /r/ sounds and repeat them.

- ساعد طفلك أن يستمع إلى الكلمات التي تحتوي على الصوتين /p/ و /r/ ويرددها.



Writing

★ Listen and trace. استمع وتتبع.

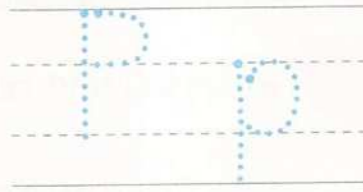
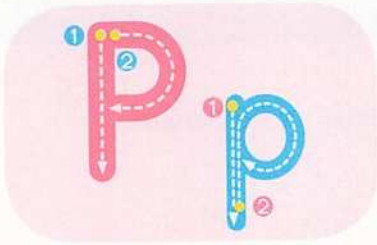

Pyramids

playground

panda

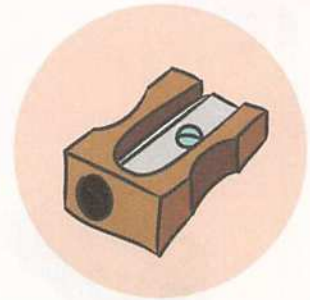
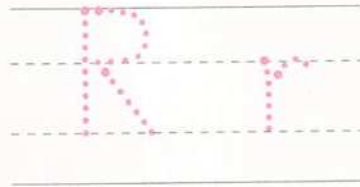
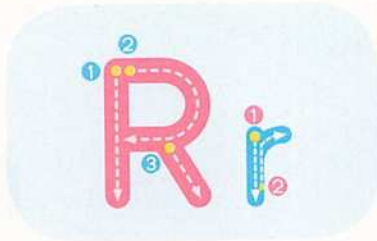

Reem

rabbit

sharpener

Notes for parents

• Ask your child to listen and trace the letters (Pp), (Rr) according to the directions.

– اطلب من طفلك أن يستمع ويتتبع الحرفين (Pp) و (Rr) وفقاً لإتجاهات الأسهم.

Writing corner

إتقان مهارة
الكتابة انظر
كراسة المعاصر
التفاعلية



★ Listen and trace. استمع وتتبع.

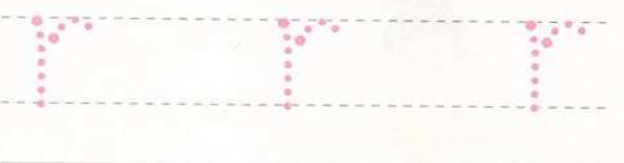
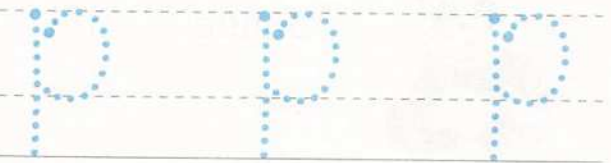
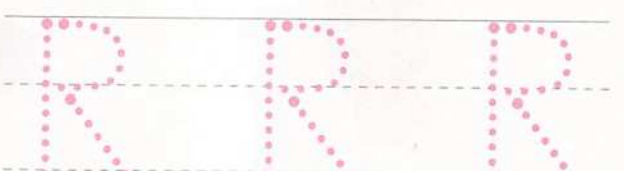
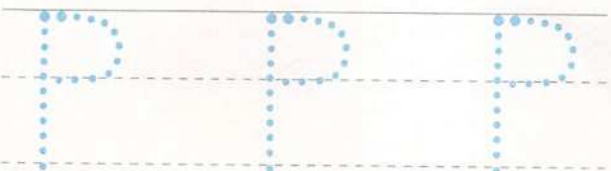
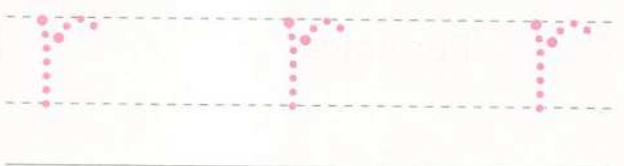
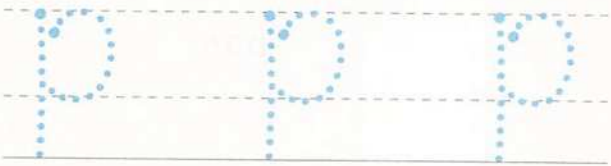
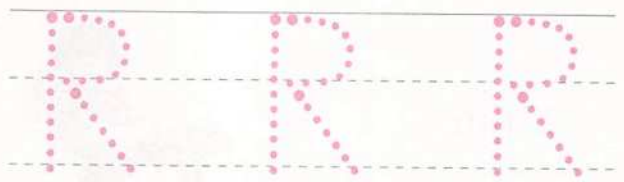
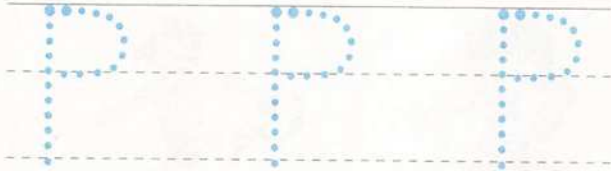
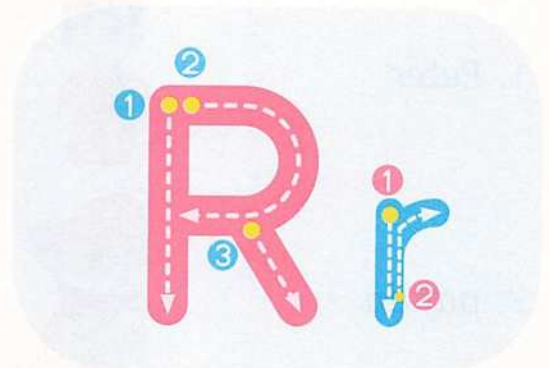
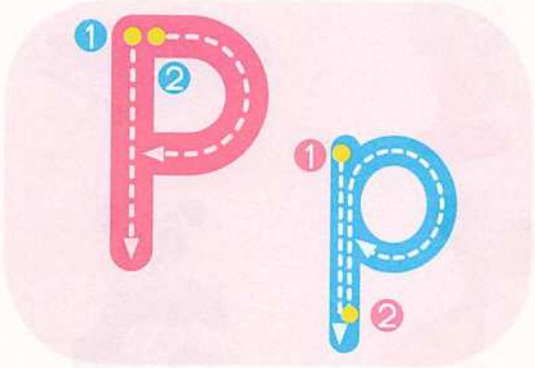

• Help your child listen to the sounds /p/ and /r/ and trace the letters (Pp) and (Rr).

- ساعد طفلك علي الاستماع إلى الصوتين /p/ ، /r/ ثم يتتبع الحرفين (Pp) ، (Rr).

Activities on Lessons 9 & 10



Put a sticker according to your assessment

1 Listen and circle. استمع وضع دائره.

1. Peter



2. panda



3. run



2 Listen and match. استمع وصل.

Pyramids

Reem

pan



3 Listen and tick (✓). استمع وضع علامة (✓).

1.



Reem

Peter

2.



panda

cat

Notes for parents

1. Ask your child to listen to the words and circle the correct picture.

- اطلب من طفلك أن يستمع إلى الكلمات ويضع دائرة حول الصورة الصحيحة.

2. Ask your child to listen to the words and match them with the correct pictures.

- اطلب من طفلك أن يستمع إلى الكلمات ويصل الكلمات بالصورة الصحيحة.

3. Ask your child to listen and tick (✓) the correct word.

- اطلب من طفلك أن يستمع ويضع علامة (✓) أمام الكلمة الصحيحة.

4 Look and circle (✓) or (X). انظر وضع دائرة حول علامة (✓) او (X).

1.



pan

✓ / X

2.



run

✓ / X

3.



camel

✓ / X

5 Trace and Color. تتبع و لون.

1.

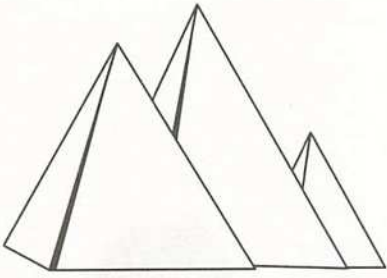

Pyramids

2.



panda

3.



run

6 Look and circle. انظر وضع دائرة.

1.



panda
camel

2.



run
pan

3.



Pyramids
playground

4. Ask your child to look and circle (✓) or (X) according to the given word.

- اطلب من طفلك أن ينظر ويضع دائرة حول علامة (✓) أو (X) وفقاً للكلمة المعطاة له.

5. Ask your child to trace the words and color the pictures.

- اطلب من طفلك أن يتتبع الكلمات ويلون الصور.

6. Ask your child to look at each picture and circle the correct word.

- اطلب من طفلك أن ينظر إلى كل صورة ويضع دائرة حول الكلمة الصحيحة.

- Connect with Science
- Growing up



Vocabulary

★ Listen and repeat. استمع وردد.

The lifecycle of a human

دورة حياة الإنسان

baby → child → teenager → adult

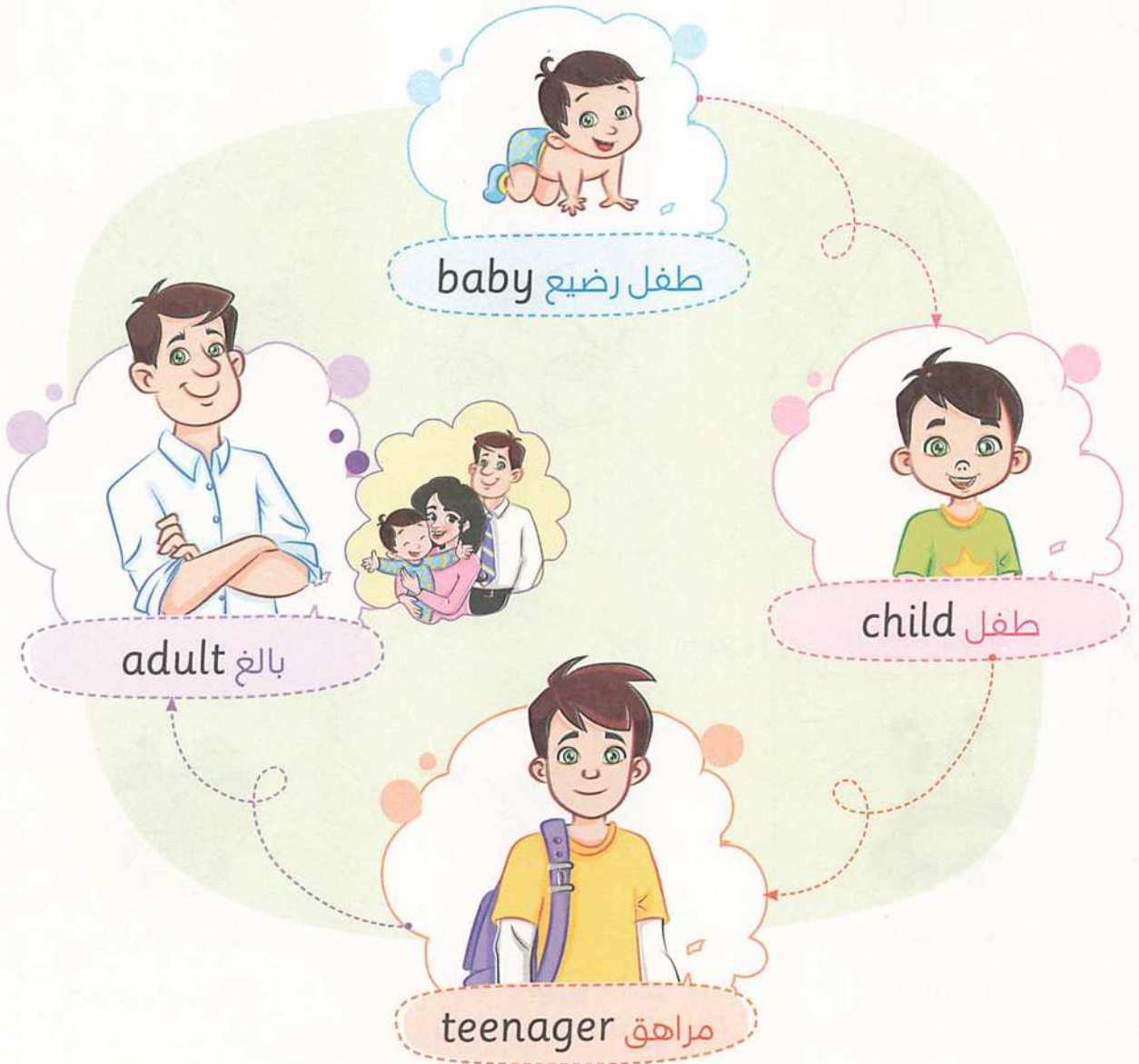

Notes for parents

- Help your child listen to the words and repeat them.
- Help your child know the lifecycle of human.

- ساعد طفلك أن يستمع إلى الكلمات ويرددها.
- ساعد طفلك أن يعرف دورة حياة الإنسان.

The lifecycle of an animal

دورة حياة حيوان



The frog

الضفدع



• Help your child to identify the lifecycle of frogs.

- ساعد طفلك أن يتعرف على دورة حياة الضفادع.

★ Activity 1

★ Match, Color and trace. صل، لون وتتبع.



teenager

baby

adult

child

Notes for parents

1. Help your child match the pictures with the words, color the pictures and trace the words.

Activity 2

★ Match each adult to its baby. صل كل بالغ بصغيره.

Adults



Babies



Activities on Lessons 11&12



Put a sticker according to your assessment

1 Listen and circle. استمع وضع دائره.

1. baby



2. teenager



3. adult



2 Listen and match. استمع وصل.

child

adult

baby



3 Listen and tick (✓). استمع وضع علامة (✓).

1.



baby

adult

2.



child

adult

Notes for parents

1. Ask your child to listen to the words and circle the correct picture.

- اطلب من طفلك أن يستمع إلى الكلمات ويضع دائرة حول الصورة الصحيحة.

2. Ask your child to listen to the words and match them with the correct pictures.

- اطلب من طفلك أن يستمع إلى الكلمات ويصل الكلمات بالصور الصحيحة.

3. Ask your child to listen and tick (✓) the correct word.

- اطلب من طفلك أن يستمع ويضع علامة (✓) أمام الكلمة الصحيحة.

4 Look and circle (✓) or (X). انظر وضع دائرة حول علامة (✓) أو (X).

1.



child

✓ / X

2.



baby

✓ / X

3.



adult

✓ / X

5 Trace and Color. تتبع ولون.

1.



child

2.



teenager

3.



adult

6 Look and circle. انظر وضع دائرة.

1.



baby

adult

2.



child

teenager

3.



adult

child

4. Ask your child to look and circle (✓) or (X) according to the given word.

- اطلب من طفلك أن ينظر ويضع دائرة حول علامة (✓) أو (X) وفقاً للكلمة المعطاة له.

5. Ask your child to trace the words and color the pictures.

- اطلب من طفلك أن يتتبع الكلمات ويلون الصور.

6. Ask your child to look at each picture and circle the correct word.

- اطلب من طفلك أن ينظر إلى كل صورة ويضع دائرة حول الكلمة الصحيحة.

A baby frog !

ضفدع رضيع !

We are kind to animals !

نحن عطوفين على الحيوانات !

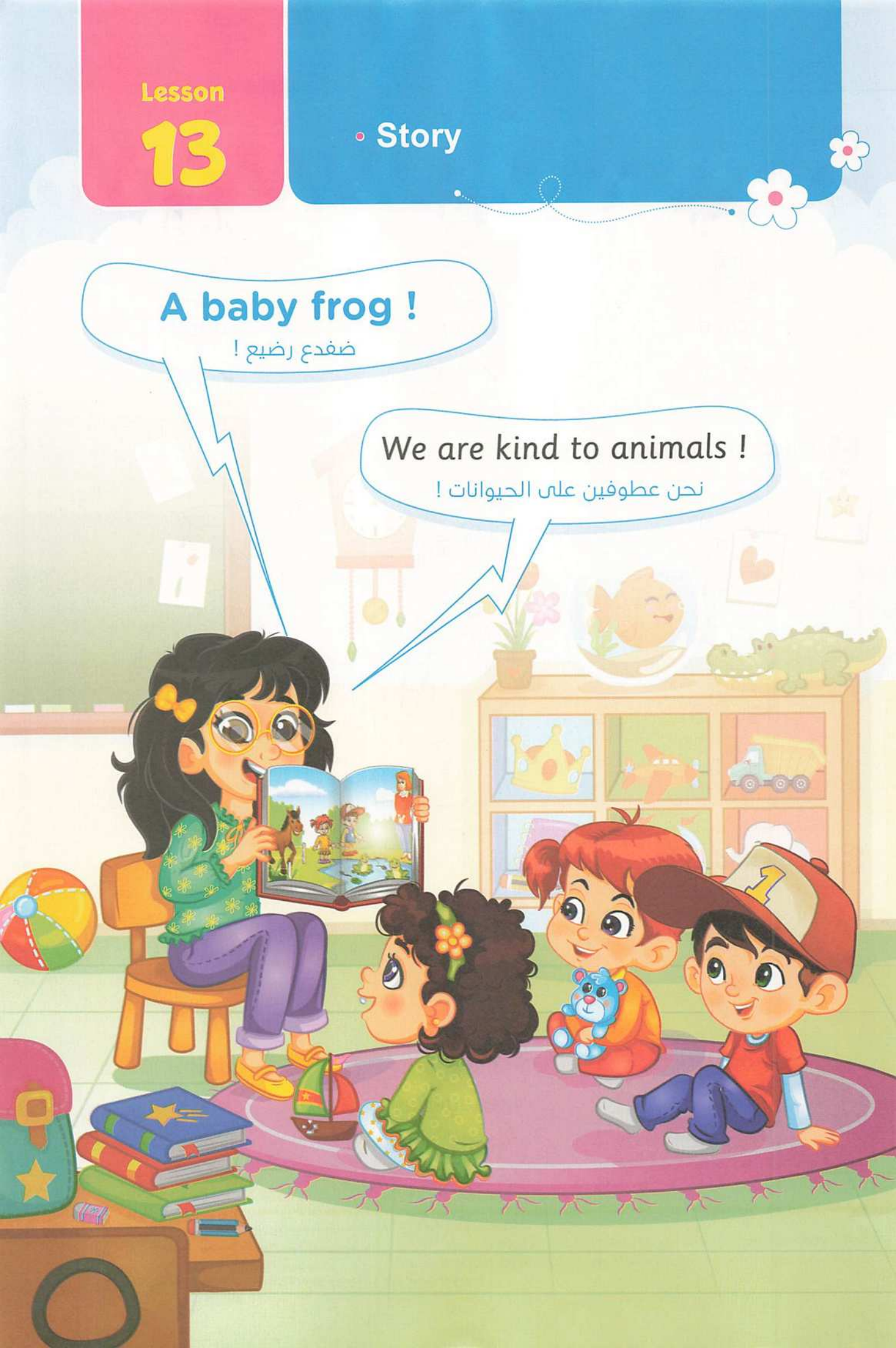

★ Listen, look and role-play : (with the masks ).

استمع، انظر وتبادل الأدوار : (باستخدام الأقنعة).

1 What is this? ما هذا ؟

Is it a fish ? Let's ask Mommy.

هل هي سمكة ؟ هيا بنا نسأل أمي.



2 Mommy, what is this ?

أمي، ما هذا ؟

This is a baby frog.

إنه ضفدع رضيع.



• Help your child listen to the scenes of the story and let him/ her say what he/ she listens to correctly, then ask him / her to role-play it with his/her colleagues with the masks.

- ساعد طفلك في الاستماع إلى مشاهد القصة ودعه يقول ما يسمعه بطريقة صحيحة ثم اطلب منه أن يتبادل الأدوار مع زملائه باستخدام الأقنعة.

3

The baby frog is a living thing.

الضفدع الرضيع كائن حي.

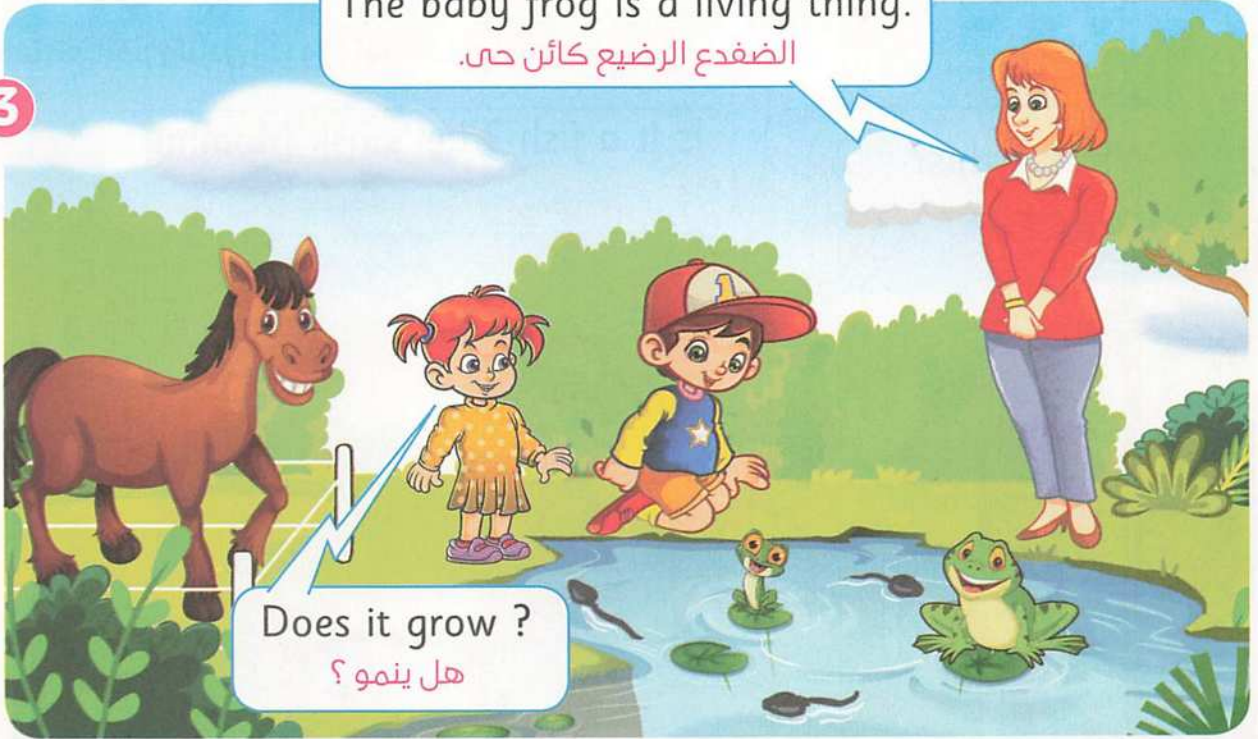

Does it grow ?

هل ينمو ؟

4

Yes, it grows to be an adult frog.

نعم ، إنه ينمو ليصبح ضفدع بالغ.

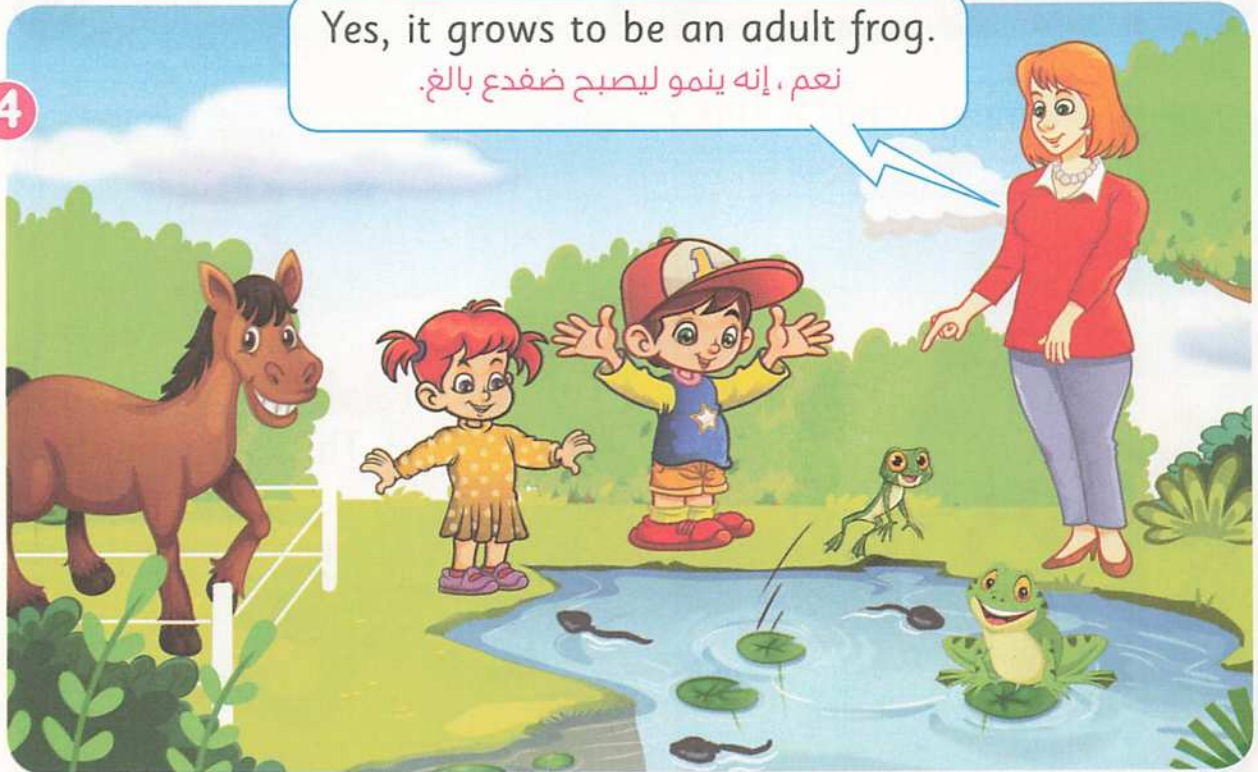

5

How can we help the baby frog ?

كيف نستطيع ان نساعد الضفدع الرضيع ؟

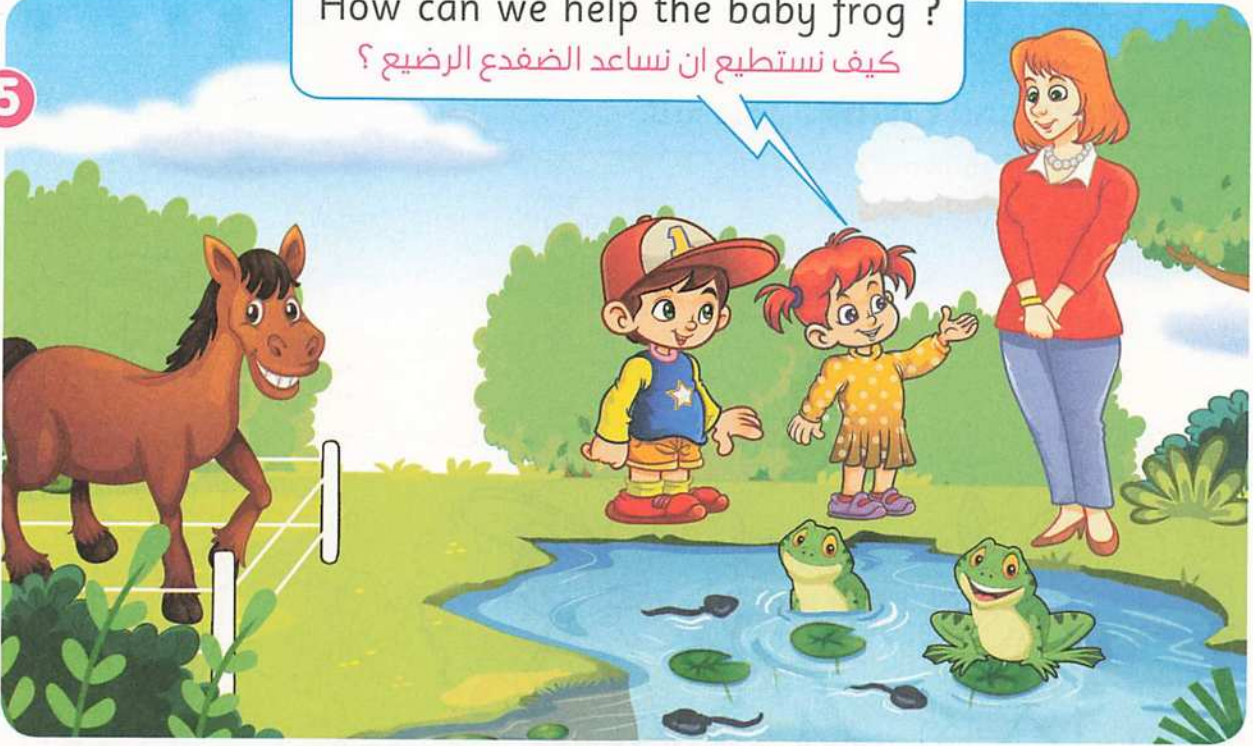

6

Frogs need water. They need food.

الضفادع تحتاج الماء. هم يحتاجوا الطعام.

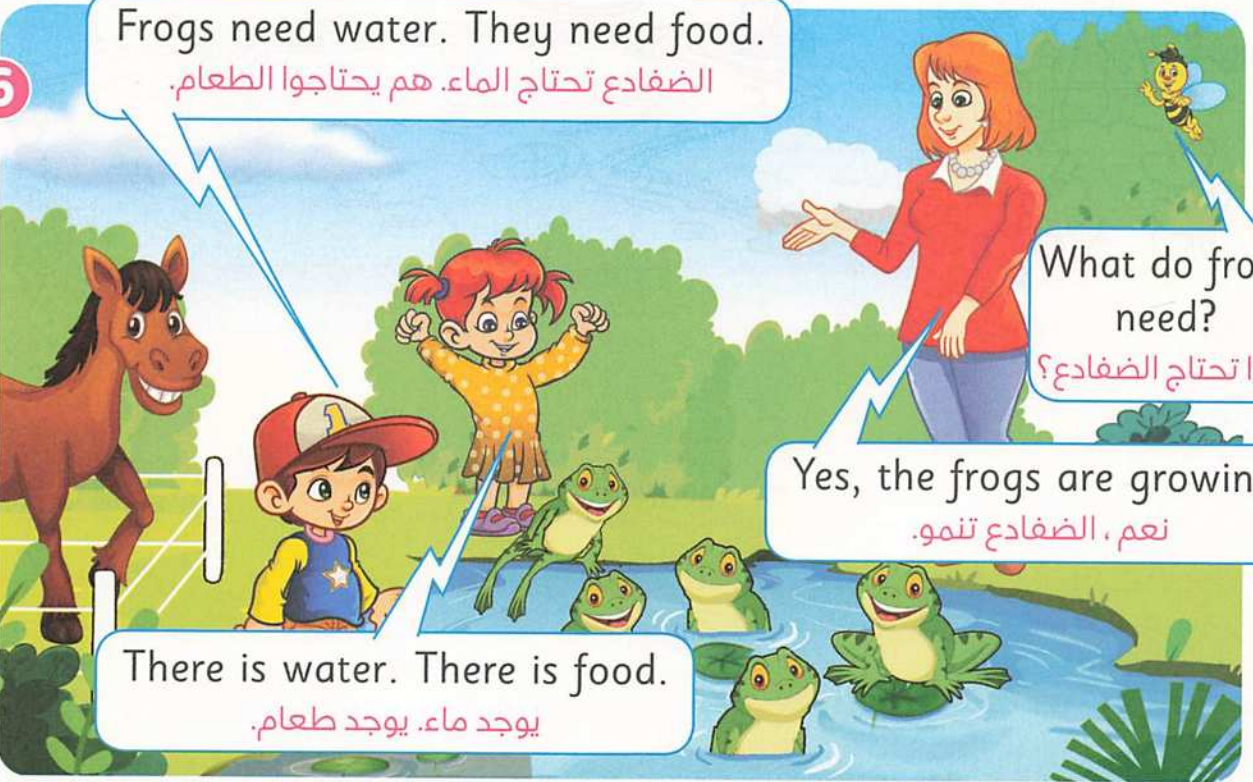

What do frogs need?

ماذا تحتاج الضفادع ؟

Yes, the frogs are growing.

نعم ، الضفادع تنمو.

There is water. There is food.

يوجد ماء. يوجد طعام.

★ Activity

★ Trace and Color. تتبع ولون.



The baby frog is a living thing.

The baby frog is a living thing.

Notes for parents

- Help your child to trace the dotted sentence and color the picture.

- ساعد طفلك أن يتتبع الجملة المكتوبة على شكل نقاط ويلون الصورة.

Activities on Lesson 13



Put a sticker according to your assessment

1 Listen and circle. استمع وضع دائره.

1. baby frog



2. food



3. grow



2 Listen and tick (✓). استمع وضع علامة (✓).

1.



adult frog

baby frog

2.



food

water

3 Look and circle (✓) or (X). انظر وضع دائرة حول علامة (✓) او (X).

1.



animals

✓ / X

2.



food

✓ / X

3.



panda

✓ / X

1. Ask your child to listen to the words and circle the correct picture.

- اطلب من طفلك أن يستمع إلى الكلمات ويضع دائرة حول الصورة الصحيحة.

2. Ask your child to listen and tick (✓) in front of the correct word.

- اطلب من طفلك أن يستمع ويضع علامة (✓) أمام الكلمة الصحيحة.

3. Ask your child to look and circle (✓) or (X) according to the given word.

- اطلب من طفلك أن ينظر ويضع دائرة حول علامة (✓) او (X) وفقاً للكلمة المعطاه له.

4 Trace and Color. تتبع ولون.

1.

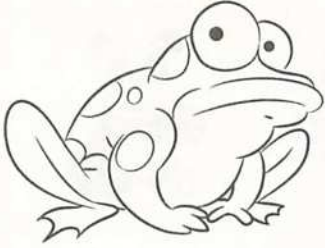

frog

2.



baby frog

3.

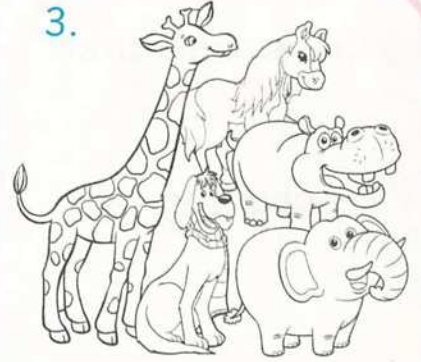

animals

5 Listen and circle. استمع وضع دائرة.

1.



Baby frogs grow / don't grow.

2.



A frog is living / non-living thing.

3.



A baby frog needs food / animals.

4.



Animals are living / non-living things.

6 Trace. تتبع.

We look after animals.

We look after animals.

Notes for parents

4. Ask your child to trace the words and color the pictures.

- اطلب من طفلك أن يتتبع الكلمات ويلون الصور.

5. Ask your child to listen to the sentences and circle the correct answer according to the given pictures.

- اطلب من طفلك أن يستمع إلى الجمل ويضع دائرة حول الإجابة الصحيحة طبقاً للصور المعطاة.

6. Ask your child to trace the given sentence.

- اطلب من طفلك أن يتتبع الجملة المعطاة.



Enjoy & learn

★ Look and Color. انظر ولوّن.

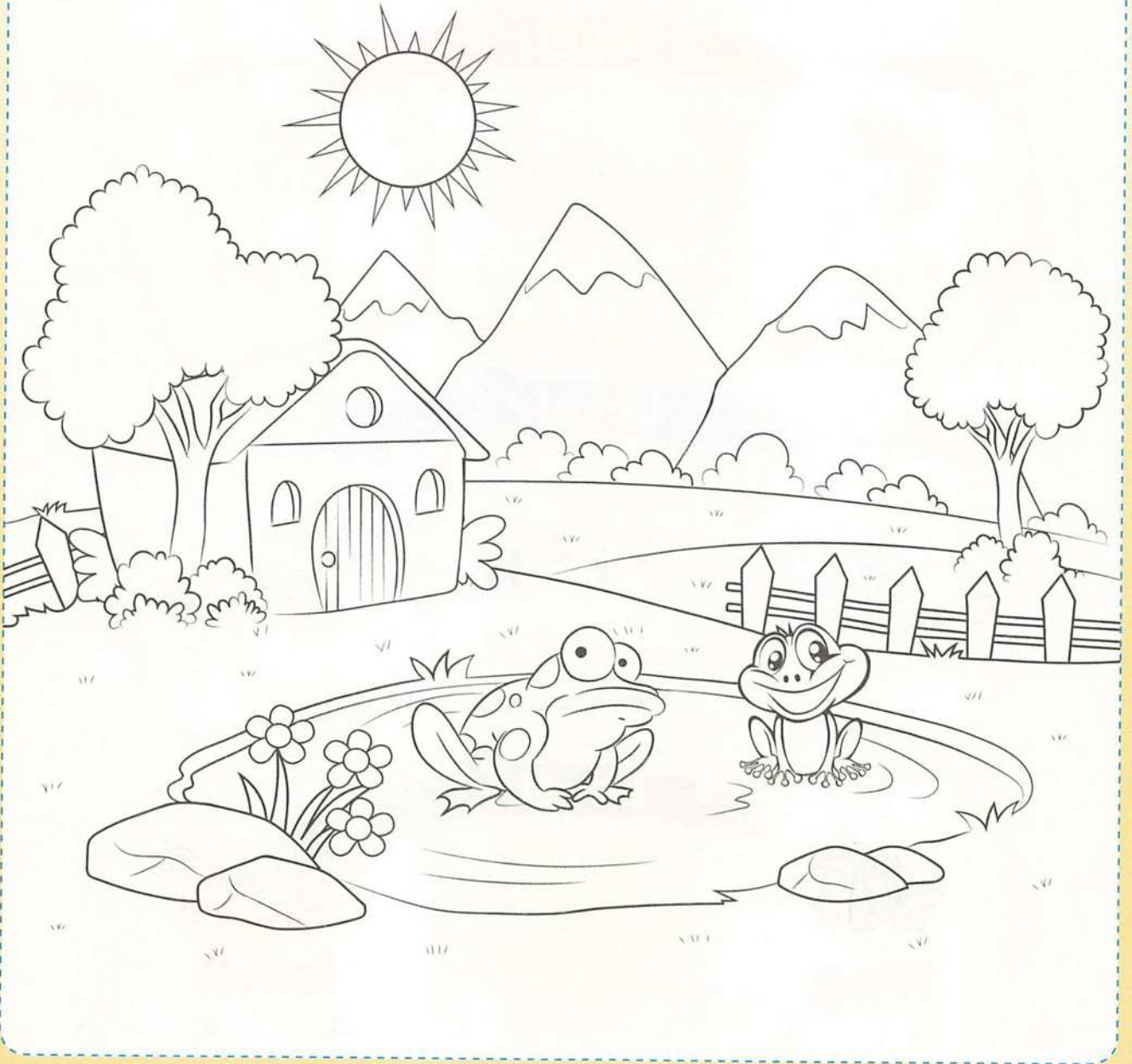

• Help your child look at the picture and color it.

– ساعد طفلك أن ينظر إلى الصورة ويلونها.



ارشادات اللعبة

Mo Game

Start →

اطلب من طفلك ان يبحث عن الصور في الكروت ويضع كل صورة على الظل المناسب لها.

Level 1 ★

اطلب من طفلك ان يستمع الي الكلمات ويبحث عنها في الكروت ويضع كل كلمة على الكلمة المناسبة لها.

Level 2 ★

اطلب من طفلك ان يستمع الي الكلمات ويبحث عن حروف كل كلمة في الكروت ويضعها لتكون الكلمة.

Level 3 ★

Level 1



Level 2

camel

fish

horse

Level 3



frog



land

1

2

3

4

1

2

3

4

* استخدم كروت اللعبة من كراسة المعاصر التفاعلية.

* يحصل الطفل علي مبلغ Mo kids 50 مكافاة مع كل اجابة صحيحة.

* يمكن للطفل ان يلعب وحدة أو يشارك زميل أو أكثر في اللعبة. والفائز هو من يحصل علي اكثر نقود.

تنويه

Review on UNIT 3

Vocabulary

sheep rabbit cat

fish horse panda

frog camel

Phonics

Rr /r/

red run rabbit

sharpener Reem

Pp /p/

pan Peter panda

Pyramids

Language

Camels live on land.

Fish live in water.

Science

baby

adult

child

teenager

Activities on Unit 3



Put a sticker according to your assessment

1 Listen and circle. استمع وضع دائره.

1. horse



2. sheep



3. fish



2 Listen and match. استمع وصل.

rabbit

sheep

horse



3 Listen and tick (✓). استمع وضع علامة (✓).

1.



sheep

horse

2.



living thing

non-living thing

Notes for parents

1. Ask your child to listen to the words and circle the correct picture.

- اطلب من طفلك أن يستمع إلى الكلمات ويضع دائرة حول الصورة الصحيحة.

2. Ask your child to listen to the words and match them with the correct pictures.

- اطلب من طفلك أن يستمع إلى الكلمات ويصل الكلمات بالصورة الصحيحة.

3. Ask your child to listen and tick (✓) in front of the correct word.

- اطلب من طفلك أن يستمع ويضع علامة (✓) أمام الكلمة الصحيحة.

4 Look and circle (✓) or (X). انظر وضع دائرة حول علامة (✓) او (X).

1.



cat

✓ / X

2.



fish

✓ / X

3.



horse

✓ / X

5 Trace and Color. تتبع ولون.

1.

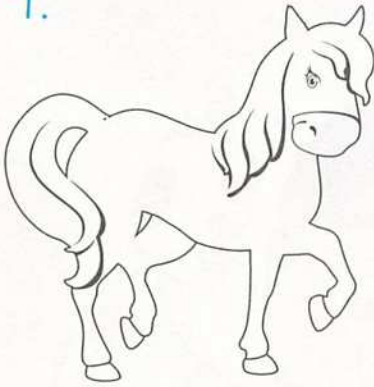

horse

2.



rabbit

3.

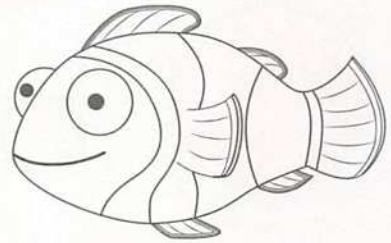

fish

6 Look and circle. انظر وضع دائرة.

1.

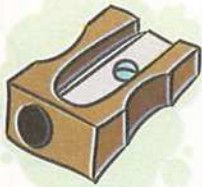

sharpener
pen

2.



fish
panda

3.



frog
camel

4. Ask your child to look and circle (✓) or (X) according to the given word.

- اطلب من طفلك أن ينظر ويضع دائرة حول علامة (✓) او (X) وفقاً للكلمة المعطاه له.

5. Ask your child to trace the words and color the pictures.

- اطلب من طفلك أن يتتبع الكلمات ويلون الصور.

6. Ask your child to look at each picture and circle the correct word.

- اطلب من طفلك أن ينظر إلى كل صورة ويضع دائرة حول الكلمة الصحيحة.

Unit
4

our world

عالمنا

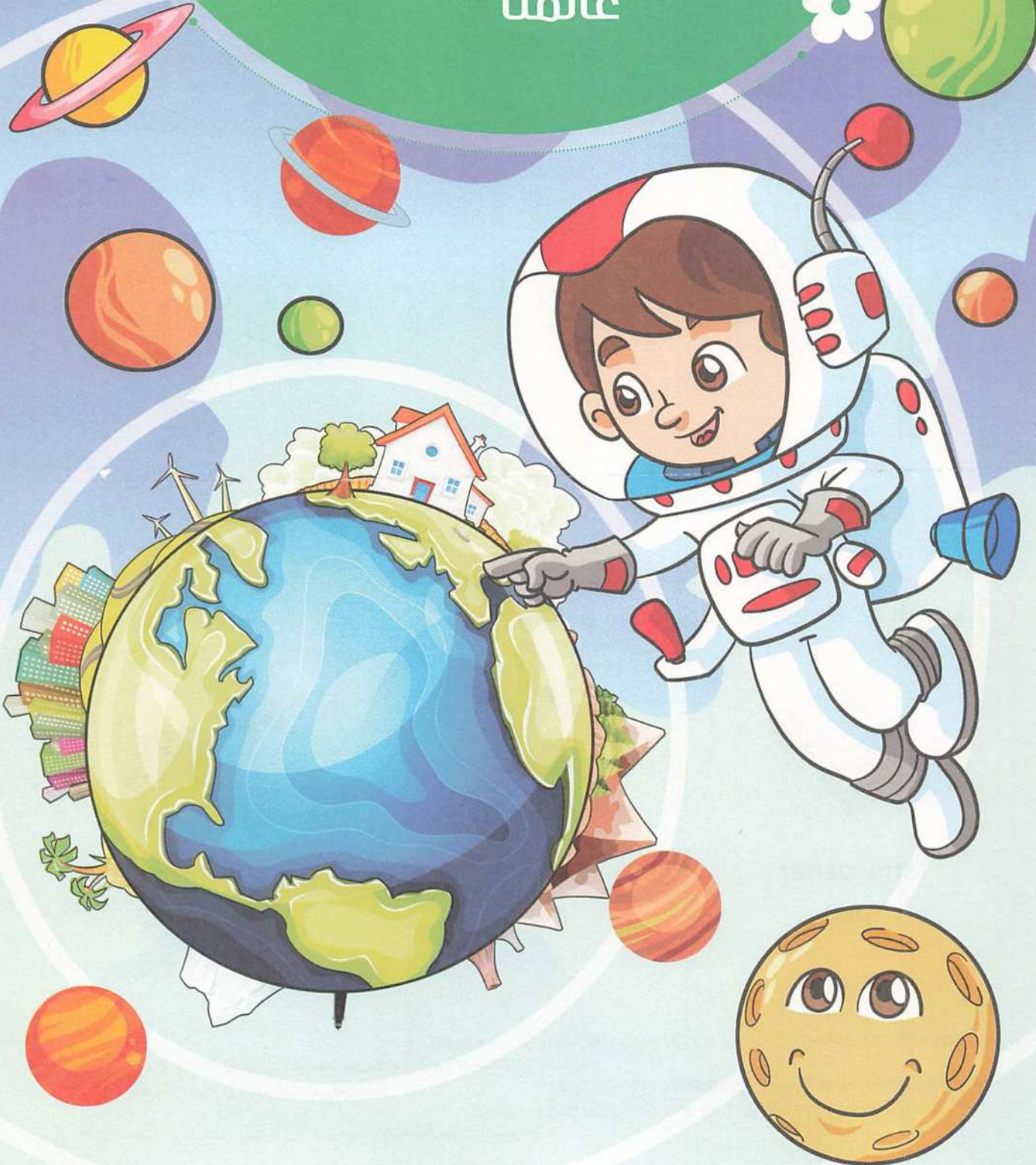

Unit 4 Objectives



Lessons 1 & 2

Objectives :

To identify salad and vegetables
أن يتعرف على السلطة والخضروات

Vocabulary :

tomato, carrot, corn, cucumber, lettuce, salad
طماطم, جزرة, ذرة, خيار, خس, سلطة.

Lesson 3

Objectives :

To be able to differentiate between food that is healthy or unhealthy for us.
- أن يكون قادرًا على ان يفرّق بين الطعام الصحي وغير الصحي لنا

Vocabulary :

sweets, cola, chocolate - كولا, شيكولاته

Language :

It's healthy/unhealthy - انه صحي / غير صحي

Lesson 4

Objectives :

1. To learn about sensible hand hygiene in different situations, including before eating
1- أن يتعلم عن نظافة اليد الصحية في مواقف مختلفة بما في ذلك قبل الأكل.
2. To have a basic idea of the concepts of before and after
2- أن يكون لديه فكره أساسية عن مصطلح قبل وبعد

Vocabulary :

hands, wash, bathroom, before, after
- أيدي, يغسل, حمام, قبل, بعد

Language :

let's wash our hands. - هيا نغسل ايدينا.

Lessons 5 & 6

Objectives :

1. To have a basic understanding of the weather
1- أن يكون لديه فهم أساسس للطقس

Vocabulary :

cloud, rain, puddle, sun
- سحابة, مطر, بركة ماء, شمس

Lesson 7

Objectives :

To talk about our environment and environmental responsibility
أن يتحدث عن بيئتنا والمسئولية البيئية

Vocabulary :

living, non-living
حي, غير حي

Lesson 8

Objectives :

To use critical thinking skills to sort items into categories based on their type
أن يستخدم مهارات التفكير النقدي ليصنف الأشياء لمجموعات طبقًا لنوعهم

Vocabulary :

red, green, yellow, cats, cows, cake, corn, apples
لون احمر, اخضر, اصفر, قطط, أبقار, كيكة, ذرة, تفاح

Lessons 9 & 10

Objectives :

To say and write D/d, S/s in speech and writing
- أن يقول ويكتب حرفي D/d , S/s في الكلام والكتابة

Vocabulary :

Daddy, duck, Dina, dog, sun, Seleem, salad, sister, sad, Sara, dig, Sami
اب, بطّة, دينّا, كلب, شمس, سليم, سلطة, اخت, حزين, سارة, يحفر, سامي

Lesson 11

Objectives :

To be able to talk about animals, vegetables and their colors
ان يكون قادرًا على التحدث عن الحيوانات والخضروات والوانها

Vocabulary :

colors, numbers to 10, duck, cat, carrot, tomato
الوان, الارقام حتى رقم 10, بطّة, قطة, جزر, طماطم

Language :

What color is it? It's a duck. It's brown
ما لونها؟ انها بطّة, لونها بني.

Lesson 12

Objectives :

To determine the difference between winter and summer
ان يحدد الفرق بين الشتاء والصيف

Vocabulary :

winter, summer
الشتاء, الصيف

Language :

I like...
انا احب...

Lesson 13

Objectives :

To identify what we need to do before eating
أن يحدد ما يجب أن نفعله قبل تناول الطعام

Issues :

Preventative health
الصحة الوقائية

Vocabulary

★ Listen and repeat. استمع وردد.

carrot جزرة

tomato طماطم

corn ذرة

lettuce خس



salad سلطة

cucumber خياره



★ Listen, look and role - play : (with the masks )

استمع، أنظر وتبادل الأدوار : (باستخدام الأقنعة)



What can you see ?

ماذا تستطيع ان تربي؟



I can see a carrot.

استطيع ان أربي جزرة.



I can see corn.

استطيع ان أربي ذرة.



I can see salad.

استطيع ان أربي سلطة.



I can see a tomato.

استطيع ان أربي ثمرة طماطم.



I can see a cucumber.

استطيع ان أربي خيارة.



I can see lettuce.

استطيع ان أربي خس.

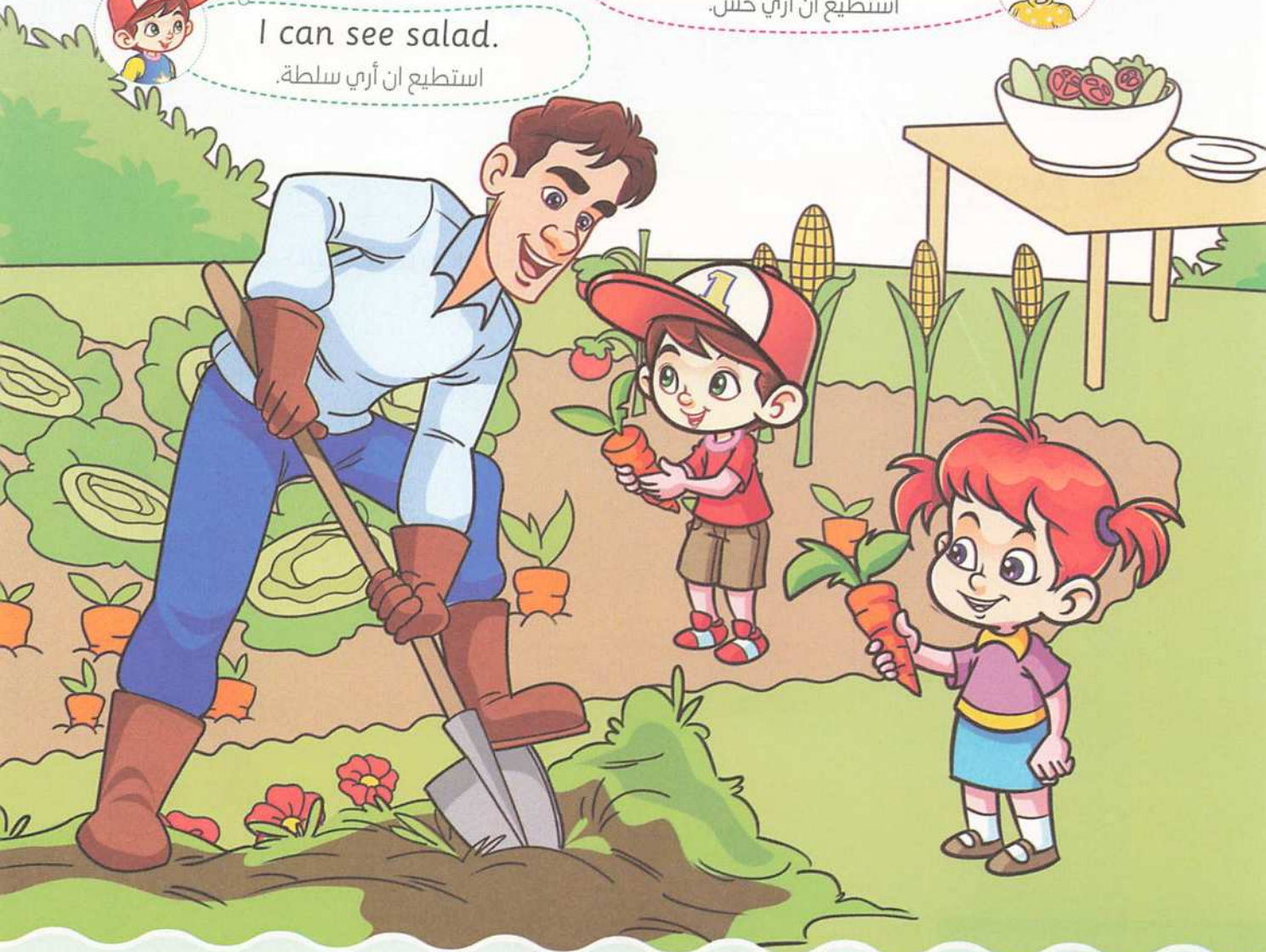

- Help your child listen to the dialogue and let him/her look at the picture, then ask him/her to role-play it with his/her colleagues with the masks.

- ساعد طفلك ان يستمع إلى المحادثة و ينظر إلى الصورة، ثم اطلب منه أن يتبادل الأدوار مع زملائه باستخدام الأقنعة.

★ Activity 1

★ Trace and Color. تتبع ولون.



★ Activity 2

★ Draw what you want to eat. ارسم ما تريد أن تأكله.

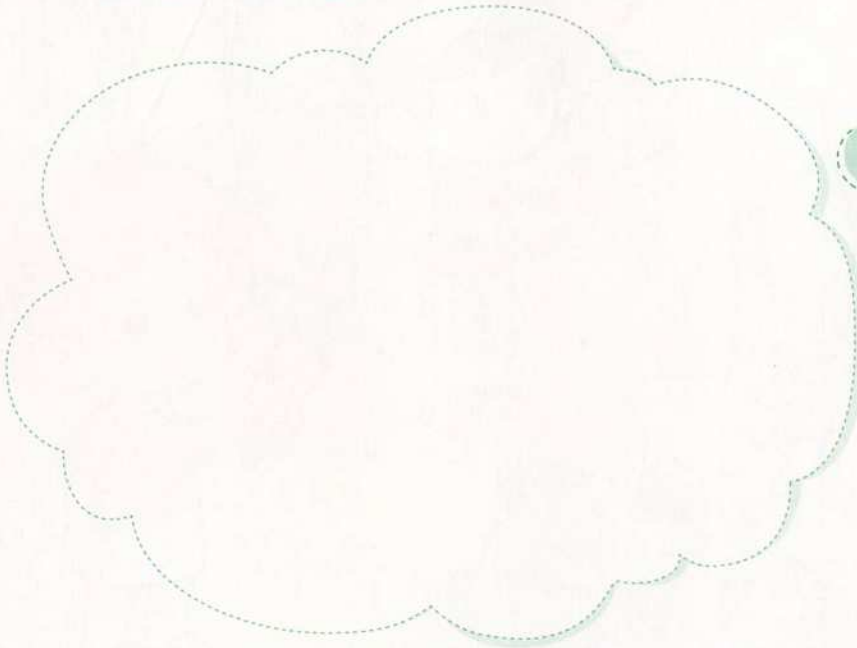

Notes for parents

- Help your child trace the picture and color it.
- Help your child draw what he / she wants to eat.

Writing corner

لإتقان مهارة
الكتابة انظر
كراسة المعاصر
التفاعلية



★ Listen and trace. استمع وتتبع.

carrot



carrot

carrot

carrot

tomato



tomato

tomato

tomato

lettuce



lettuce

lettuce

lettuce

corn



corn

corn

corn

cucumber



cucumber

cucumber

cucumber

salad



salad

salad

salad

Activities on Lessons 1&2



Put a sticker according to your assessment

1 Listen and circle. استمع وضع دائره.

1. carrot



2. cucumber



3. corn



2 Listen and match. استمع وصل.

salad

lettuce

carrot



3 Listen and tick (✓). استمع وضع علامة (✓).

1.



corn

tomato

2.



lettuce

salad

Notes for parents

1. Ask your child to listen to the words and circle the correct picture.

- اطلب من طفلك أن يستمع إلى الكلمات ويضع دائرة حول الصورة الصحيحة.

2. Ask your child to listen to the words and match them with the correct pictures.

- اطلب من طفلك أن يستمع إلى الكلمات ويصل الكلمات بالصورة الصحيحة.

3. Ask your child to listen and tick (✓) the correct word.

- اطلب من طفلك أن يستمع ويضع علامة (✓) أمام الكلمة الصحيحة.

4 Look and circle (✓) or (X). انظر وضع دائرة حول علامة (✓) او (X).

1.

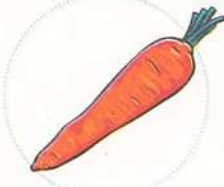

corn

✓ / X

2.



tomato

✓ / X

3.



salad

✓ / X

5 Trace and Color. تتبع ولون.

1.

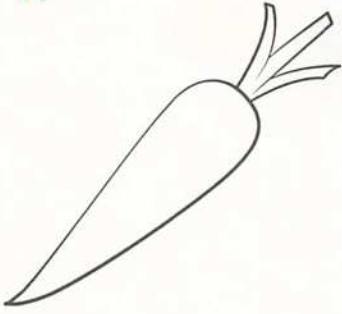

carrot

2.

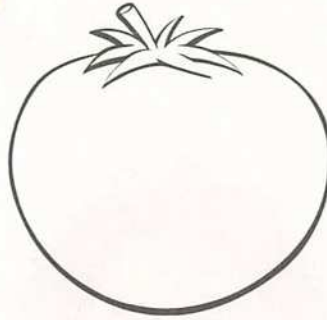

tomato

3.

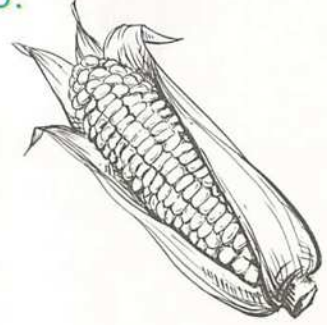

corn

6 Look and circle. انظر وضع دائرة.

1.



cucumber

corn

2.



tomato

lettuce

3.

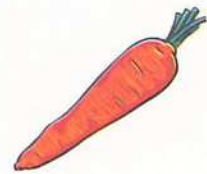

carrot

salad

4. Ask your child to look and circle (✓) or (X) according to the given word.

- اطلب من طفلك أن ينظر ويضع دائرة حول علامة (✓) او (X) طبقا للكلمة المعطاة له.

5. Ask your child to trace the words and color the pictures.

- اطلب من طفلك أن يتتبع الكلمات ويلون الصور.

6. Ask your child to look at each picture and circle the correct word.

- اطلب من طفلك أن ينظر إلى كل صورة ويضع دائرة حول الكلمة الصحيحة.

Lesson

3

- Language use
- Healthy or unhealthy



Vocabulary

★ Listen and repeat. استمع وردد.

chocolate شيكولاتة



sweets حلوى



water ماء



cola

كولا / مياه غازية



Notes for parents

Language

★ healthy food

الطعام الصحي

It's healthy. انه صحى.



★ unhealthy food

الطعام الغير صحى

It's unhealthy. انه غير صحى.



Activity

★ **Color** the **healthy** food with 
and the **unhealthy** food with  .

لون الطعام الصحي باللون الأخضر والطعام الغير صحي باللون الأحمر.

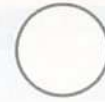
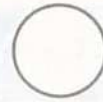
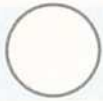
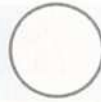

Notes for parents

• Help your child color the healthy food in green and the unhealthy food in red.

Activities on Lesson 3



Put a sticker according to your assessment

1 Listen and circle. استمع وضع دائره.

1. tomato



2. cola



3. water

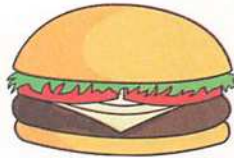

2 Listen and match. استمع وصل.

chocolate

sweets

water

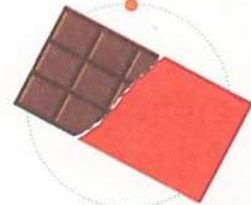

3 Listen and tick (✓). استمع وضع علامة (✓).

1.



It's healthy.

It's unhealthy.

2.



It's healthy.

It's unhealthy.

1. Ask your child to listen to the words and circle the correct picture.

2. Ask your child to listen to the words and match them with the correct pictures.

3. Ask your child to listen and tick (✓) the correct sentences.

Activities on Lesson 3

4 Look and circle (✓) or (X). انظر وضع دائرة حول علامة (✓) او (X).

1.



unhealthy

✓ / X

2.



cucumber

✓ / X

3.



tomato

✓ / X

5 Trace and Color. تتبع ولون.

1.

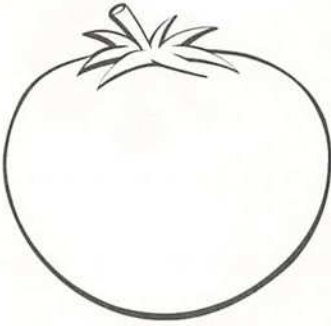

tomato

2.

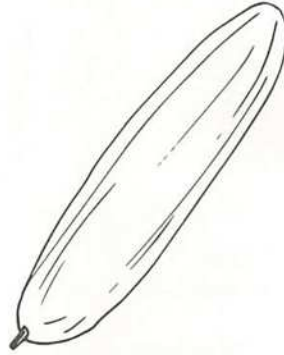

cucumber

3.



chocolate

6 Listen and circle. استمع وضع دائرة.

1.



It's healthy .
unhealthy

2.



It's healthy .
unhealthy

3.



Water is healthy .
Cola

4.



It's unhealthy .
They're

Notes for parents

4. Ask your child look at the pictures and circle (✓) or (X) according to the given word.

- اطلب من طفلك أن ينظر إلى الصور ويضع دائرة حول علامة (✓) او (X) طبقاً للكلمة المعطاة له.

5. Ask your child to trace the words and color the pictures.

- اطلب من طفلك أن يتتبع الكلمات ويلون الصور.

6. Ask your child to listen to the sentences and circle the correct answer according to the given pictures.

- اطلب من طفلك أن يستمع إلى الجمل ويضع دائرة حول الإجابة الصحيحة طبقاً للصور المعطاة.

Lesson

4

- Issues
- Let's wash our hands !

Vocabulary

★ Listen and repeat. استمع وردد.

wash يغسل

eat تأكل

hands أيدي

baby طفل رضيع

use يستخدم

Let's wash our hands !

هيا بنا نغسل ايدينا!

animals حيوانات

touch تلمس

bathroom حمام

cough يكح

Language

Let's inf. المصدر

هيا بنا.....



Let's wash our hands.
هيا بنا نغسل أيدينا.



Let's wash our hands

before قبل



we eat. أن نأكل.



we touch a baby.
أن نلمس طفل رضيع.

Let's wash our hands

after بعد



we use the bathroom.
أن نستخدم دورة المياه.



we touch animals.
أن نلمس الحيوانات.



we cough.
أن نكح.

Notes for parents

Sing



Let's wash our hands,
Before we eat,
Before we eat,
Before we eat.
Let's wash our hands,
Before we eat.
Every day !



Let's wash our hands,
After the bathroom,
After the bathroom,
After the bathroom.
Let's wash our hands,
After the bathroom.
Every day !

Activity

★ Look and stick. انظر والصق.



Let's wash our hands

after بعد



before قبل



Notes for parents

• Help your child to look at the pictures and stick before or after according to the given picture.

Activities on Lesson 4



Put a sticker according to your assessment

1 Listen and circle. استمع وضع دائره.

1. bathroom



2. baby



3. hands

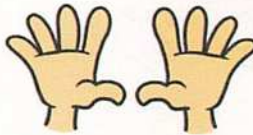

2 Listen and match. استمع وصل.

cough

wash

touch



3 Listen and tick (✓). استمع وضع علامة (✓).

1.



touch a baby

touch an animal

2.



animal

bathroom

1. Ask your child to listen to the words and circle the correct picture.

- اطلب من طفلك ان يستمع إلى الكلمات ويضع دائرة حول الصورة الصحيحة.

2. Ask your child to listen to the words and match them with the correct pictures.

- اطلب من طفلك ان يستمع إلى الكلمات ويصل الكلمات بالصور الصحيحة.

3. Ask your child to listen and tick (✓) the correct word.

- اطلب من طفلك ان يستمع ويضع علامة (✓) أمام الكلمة الصحيحة.

Lessons
5&6

- Connect with Science
- Listening and speaking

Vocabulary

★ Listen and repeat. استمع وردد.

sun شمس



cloud سحابة



puddle بركة مياه

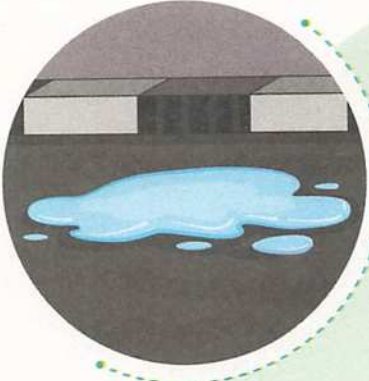

rain مَطَر / تَمَطِر



sea بحر

Notes for parents

Language

Talking about the benefits of the sun and the rain.

التحدث عن فوائد الشمس والمطر.



• Help your child learn about the benefits of the sun and rain for the plants he/she eats.

- ساعد طفلك أن يتعلم عن فوائد الشمس والمطر للنباتات التي يأكلها / تأكلها.

Activities on Lessons 5&6



Put a sticker according to your assessment

1 Listen and circle. استمع وضع دائره.

1. sea



2. cloud



3. rain



2 Listen and match. استمع وصل.

puddle

sea

rain



3 Listen and tick (✓). استمع وضع علامة (✓).

1.



rain

puddle

2.



cloud

rain

Notes for parents

1. Ask your child to listen to the words and circle the correct picture.

- اطلب من طفلك أن يستمع إلى الكلمات ويضع دائرة حول الصورة الصحيحة.

2. Ask your child to listen to the words and match them with the correct pictures.

- اطلب من طفلك أن يستمع إلى الكلمات ويصل الكلمات بالصورة الصحيحة.

3. Ask your child to listen and tick (✓) the correct word.

- اطلب من طفلك أن يستمع ويضع علامة (✓) أمام الكلمة الصحيحة.

4 Look and circle (✓) or (X). انظر وضع دائرة حول علامة (✓) او (X).

1.



sea

✓ / X

2.



puddle

✓ / X

3.



water

✓ / X

5 Trace and Color. تتبع و لون.

1.

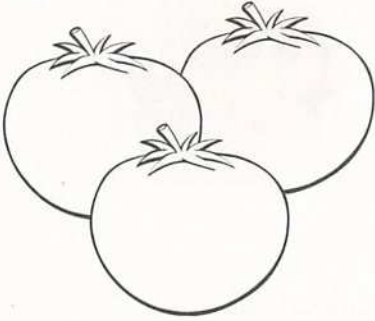

tomatoes

2.



rain

3.

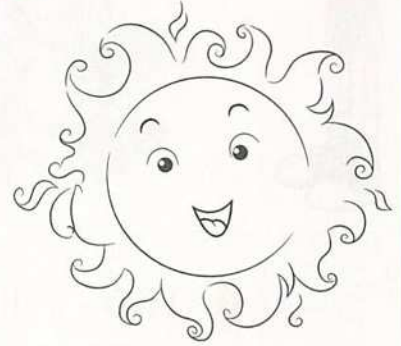

sun

6 Look and circle. انظر و ضع دائرة.

1.



rain

sun

2.



puddle

water

3.



sea

cloud

4. Ask your child look and circle (✓) or (X) according to the given word.

- اطلب من طفلك أن ينظر ويضع دائرة حول علامة (✓) او (X) طبقا للكلمة المعطاة له.

5. Ask your child to trace the words and color the pictures.

- اطلب من طفلك أن يتبع الكلمات ويلون الصور.

6. Ask your child to look at each picture and circle the correct word.

- اطلب من طفلك أن ينظر إلى كل صورة ويضع دائرة حول الكلمة الصحيحة.

- Issues
- Living or non-living?

★ Listen and look. استمع وانظر.

★ One - syllable words كلمات ذات مقطع واحد



frog ضفدع



duck بطة



fish سمكة



★ Two - syllable words كلمات ذات مقطعين

water ماء



bottle زجاجة

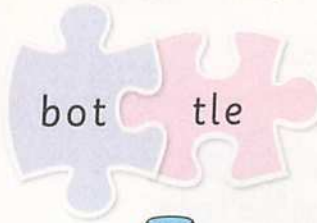

river نهر

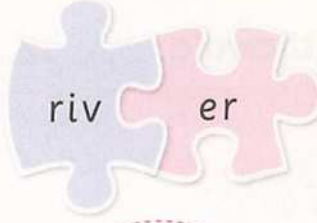

LEARN



★ Living things: كائنات حية



★ Non-living things : كائنات غير حية



★ Activity

★ Look and sort. انظر و صنف الأشياء.



Living



Non-living



Notes for parents

• Help your child sort the objects into living or non-living by ticking (✓) in front of the correct choice.

– ساعد طفلك أن يصنف الأشياء الحية والغير الحية عن طريق وضع علامة (✓) أمام الاختيار الصحيح.

Activities on Lesson 7



Put a sticker according to your assessment

1 Listen and match. استمع وصل.

1. river



2. water



3. frog



2 Listen and tick (✓). استمع وضع علامة (✓).

1.



duck
bottle

2.



fish
frog

3 Trace and Color. تتبع ولون.

1.

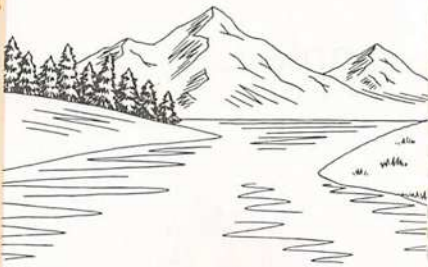

river

2.



bottle

3.

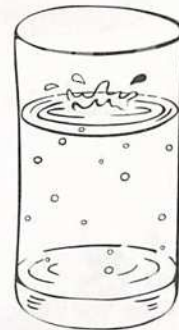

water

1. Ask your child to listen to the words and match them with the correct pictures.

- اطلب من طفلك أن يستمع إلى الكلمات ويصل الكلمات بالصور الصحيحة.

2. Ask your child to listen and tick (✓) the correct word.

- اطلب من طفلك أن يستمع ويضع علامة (✓) أمام الكلمة الصحيحة.

3. Ask your child to trace the words and color the pictures.

- اطلب من طفلك أن يتتبع الكلمات ويلون الصور.

- Language use
- Sorting

Vocabulary

★ Listen and repeat. استمع وردد.

colors الألوان



red أحمر



yellow أصفر



green أخضر

food الطعام



cake كعكة



corn ذرة



apple تفاحة

animals الحيوانات



COW بقرة



cat قطة

Notes for parents

- Help your child learn how to sort things.
- Help your child listen to the words and repeat them.

- ساعد طفلك أن يتعلم كيف يصنف الأشياء.
- ساعد طفلك أن يستمع إلي الكلمات و يرددها.

Activity

★ Match each picture to the correct sorting.

صل كل صورة بالتصنيف الصحيح.



colors



animals



food



Activities on Lesson 8



Put a sticker according to your assessment

1 Listen and circle. استمع وضع دائرة.

1. food



2. animals



3. colors



2 Listen and match. استمع وصل.

1. food

2. colors

3. animals



3 Listen and tick (✓). استمع وضع علامة (✓).

1.



animal
color

2.



food
animal

Notes for parents

1. Ask your child to listen to the words and circle the correct picture.

اطلب من طفلك أن يستمع إلى الكلمات ويضع دائرة حول الصورة الصحيحة.

2. Ask your child to listen to the words and match them with the correct pictures.

اطلب من طفلك أن يستمع إلى الكلمات ويصل الكلمات بالصورة الصحيحة.

3. Ask your child to listen and tick (✓) the correct word.

اطلب من طفلك أن يستمع ويضع علامة (✓) أمام الكلمة الصحيحة.

4 Look and circle (✓) or (X). انظر وضع دائرة حول علامة (✓) او (X).

1.



animals

✓ / X

2.



cats

✓ / X

3.



colors

✓ / X

5 Trace and Color. تتبع ولون.

1.



animals

2.

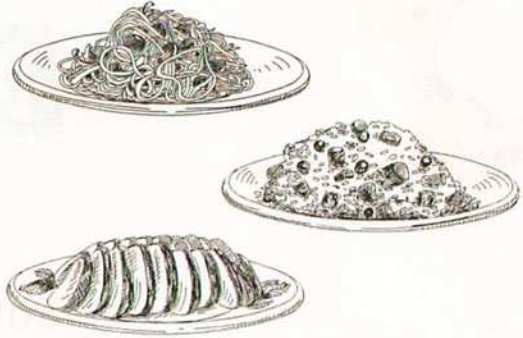

food

6 Listen and complete. استمع وأكمل.

food - colors - animals

1.



Red and blue are

2.



Horse and sheep are

4. Ask your child to look and circle (✓) or (X) according to the given word.

- اطلب من طفلك أن ينظر ويضع دائرة حول علامة (✓) او (X) طبقاً للكلمة المعطاة له.

5. Ask your child to trace the words and color the pictures.

- اطلب من طفلك أن يتتبع الكلمات ويلون الصور.

6. Ask your child to listen to the sentences and complete them according to the words in the above box.

- اطلب من طفلك أن يستمع الي الجمل و يكملها طبقاً للكلمات التي في الصندوق اعلاه.

Lessons
9&10

- Learn sounds with Busy Bee !
- Learn to write with Busy Bee !



Phonics

★ Listen and repeat. استمع وردد.

daddy أب



duck بطة



Dina دينا



dog كلب



hand يد



D d

salad سلطة



sad حزين



sister أخت



S s

Sara سارة



sun شمس

Seleem سليم



Notes for parents

- Help your child listen to the words that have the /d/ and /s/ sounds and repeat them.

– ساعد طفلك أن يستمع إلى الكلمات التي تحتوي على النطق الصوتي للصوتين /d/ و /s/ ويرددها.



Writing

★ Listen and trace. استمع وتتبع.

D d

D d



Dina

duck

daddy

hand

S s

S s



Seleem

sun

sister

salad

• Ask your child to listen and identify the words that have /d/ and /s/ sounds and trace the words.

- اطلب من طفلك ان يستمع ويتعرف على الكلمات التي بها الصوتين /d/ ، /s/ وان يتتبع الكلمات.

Writing corner

إتقان مهارة
الكتابة النظر
كراسة المعاصر
التفاعلية



★ Listen and trace. استمع وتتبع.

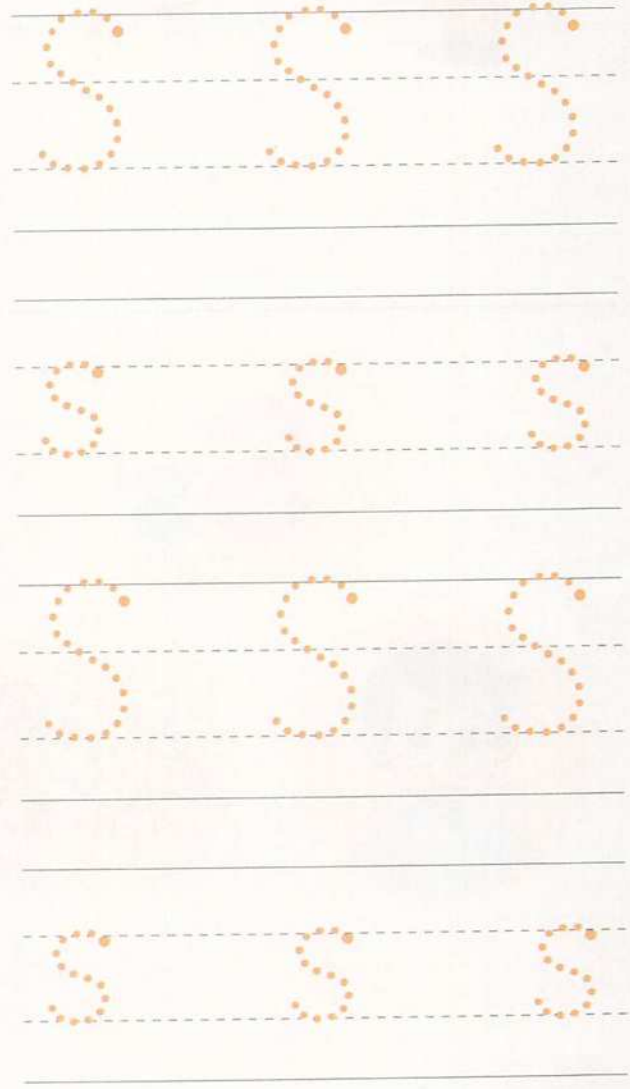
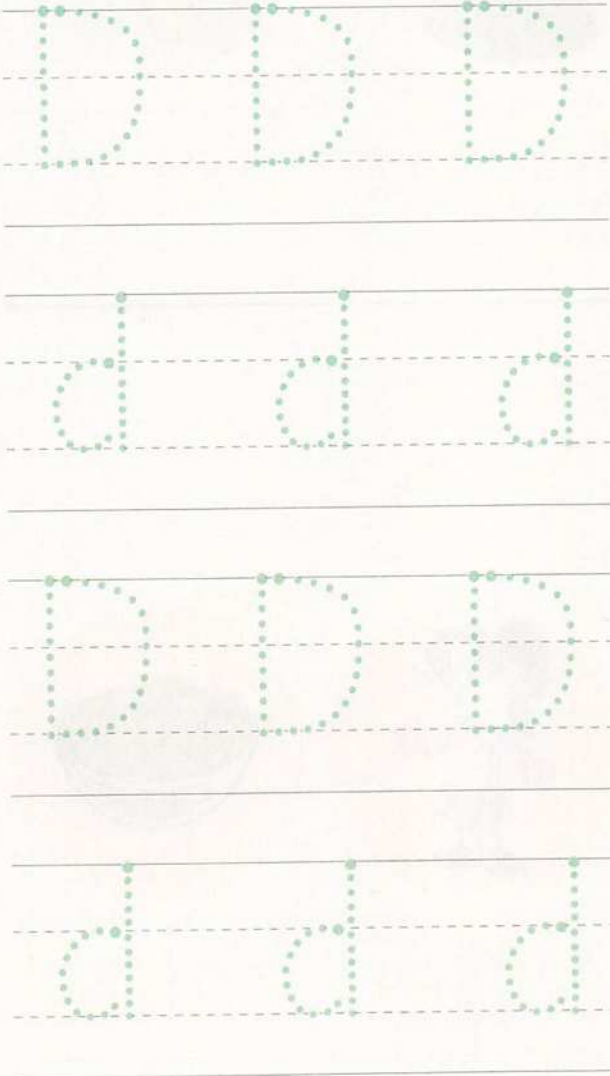

Notes for parents

• Help your child listen to /d/ and /s/ sounds and trace the letters (Dd) and (Ss).

- ساعد طفلك على الاستماع إلى الصوتين /d/ ، /s/ ثم يتتبع الحرفين (Dd) ، (Ss).

Activities on Lessons 9 & 10



Put a sticker according to your assessment

1 Listen and circle. استمع وضع دائره.

1. Dina



2. dog



3. hand



2 Listen and match. استمع وصل.

duck

sun

Seleem



3 Listen and tick (✓). استمع وضع علامة (✓).

1.



duck

dog

2.



salad

sun

1. Ask your child to listen to the words and circle the correct picture.

- اطلب من طفلك أن يستمع إلى الكلمات ويضع دائرة حول الصورة الصحيحة.

2. Ask your child to listen to the words and match them with the correct pictures.

- اطلب من طفلك أن يستمع إلى الكلمات ويصل الكلمات بالصورة الصحيحة.

3. Ask your child to listen and tick (✓) the correct word.

- اطلب من طفلك أن يستمع ويضع علامة (✓) أمام الكلمة الصحيحة.

Activities on Lessons 9&10

4 Look and circle (✓) or (X). انظر وضع دائرة حول علامة (✓) أو (X).

1.



cloud

✓ / X

2.



duck

✓ / X

3.



daddy

✓ / X

5 Trace and Color. تتبع ولون.

1.

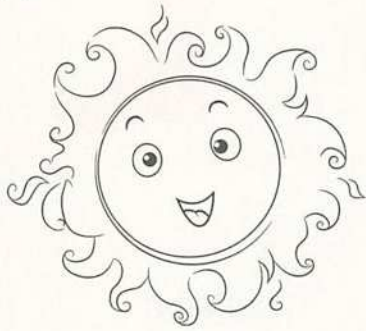

sun

2.

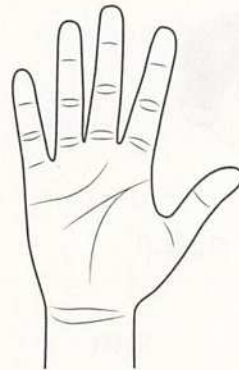

hand

3.

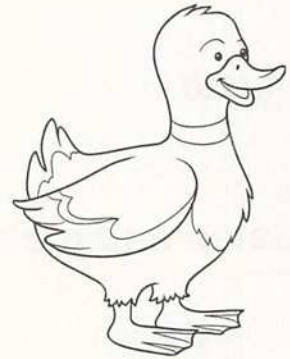

duck

6 Circle and write. ضع دائرة وأكتب.

1.



- uck

d

b

r

2.



- and

t

s

h

Notes for parents

4. Ask your child to look and circle (✓) or (X) according to the given word.

- اطلب من طفلك أن ينظر ويضع دائرة حول علامة (✓) أو (X) طبقاً للكلمة المعطاة له.

5. Ask your child to trace the words and color the pictures.

- اطلب من طفلك أن يتتبع الكلمات ويلون الصور.

6. Ask your child to circle the correct letter and write it.

- اطلب من طفلك أن يضع دائرة حول الحرف الصحيح ويكتبه.

Lesson

11

• Connect with Art

Vocabulary

★ Listen and repeat. استمع وردد.

yellow أصفر

green أخضر

blue أزرق

brown بني

Colors

الألوان

red أحمر

orange برتقالي

gray رمادي

black أسود

white أبيض

• Help your child listen to the words and repeat them.

– ساعد طفلك أن يستمع إلى الكلمات ويردها.



Activity

★ Listen, look and Color.

استمع، انظر ولون.

It's a cat. What color is it?

It' gray.

- One is red
- Two is blue
- Three is yellow
- Four is green
- Five is orange
- Six is brown
- Seven is white
- Eight is gray
- Nine is black

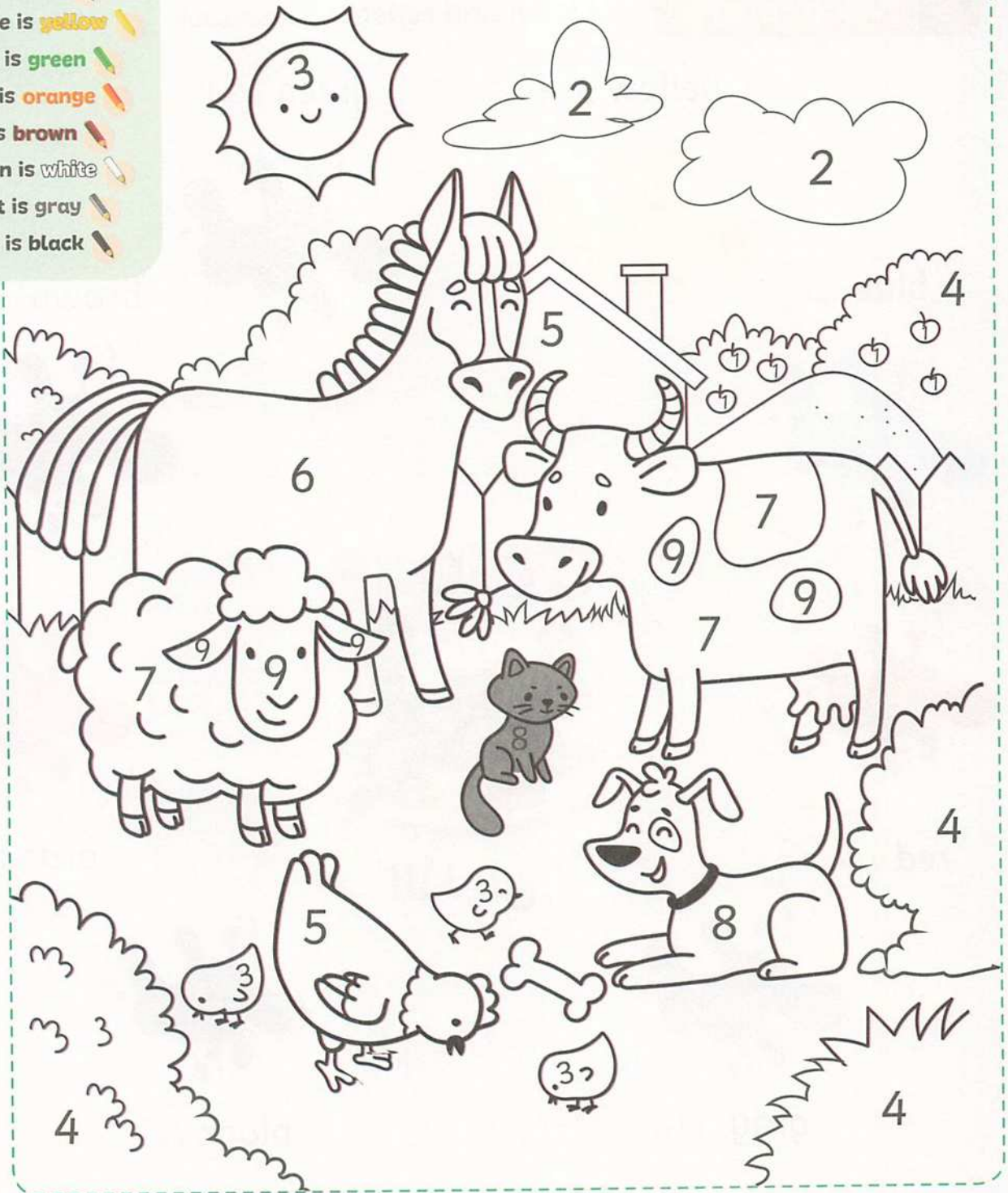

Notes for parents

- ساعد طفلك ان يستمع وينظر للصورة ويلون وفقاً للارقام.
- Help your child to listen, look at the picture and color according to the numbers.
- ساعد طفلك ان يسأل ويجيب اسئلة عن الاشياء ولوانها باستخدام (ما لون?).
- Help your child to ask and answer about things and their colors using "what color.....?".
- ساعد طفلك ان يتحدث عن الاشياء المفردة باستخدام (It's). بمعنى (انه/ انها).
- Help your child to talk about singular things using (It's).

Activities on Lesson 11



Put a sticker according to your assessment

1 Listen and circle. استمع وضع دائره.

1. red



2. yellow



3. white

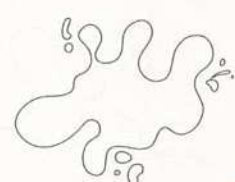

2 Listen and match. استمع وصل.

gray

green

orange



3 Listen and tick (✓). استمع وضع علامة (✓).

1.  green
blue

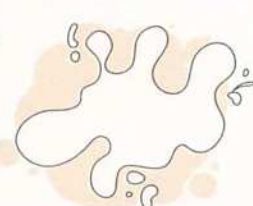
2.  black
white

1. Ask your child to listen to the words and circle the correct color.

- اطلب من طفلك أن يستمع إلى الكلمات ويضع دائرة حول اللون الصحيح.

2. Ask your child to listen to the words and match them with the correct colors.



- اطلب من طفلك أن يستمع إلى الكلمات ويصل الكلمات بالألوان الصحيحة.

3. Ask your child to listen and tick (✓) the correct word.

- اطلب من طفلك أن يستمع ويضع علامة (✓) أمام الكلمة الصحيحة.

Activities on Lesson 11



4 Look and circle (✓) or (X). انظر وضع دائرة حول علامة (✓) او (X).

1.  black ✓ / X	2.  green ✓ / X	3.  yellow ✓ / X
--	--	---

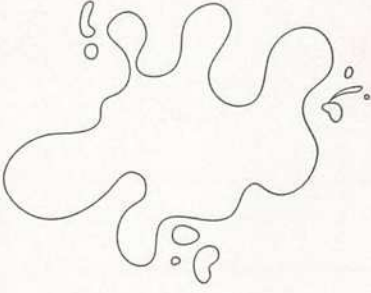
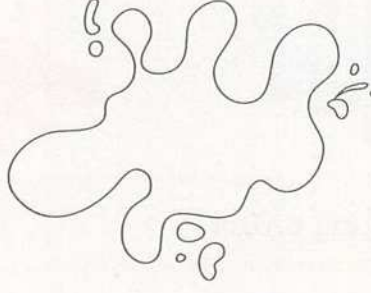
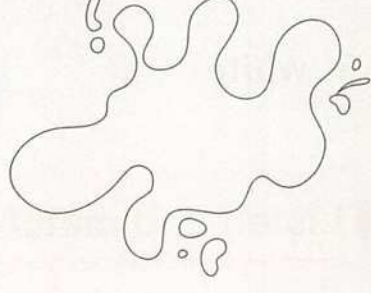
5 Trace and Color. تتبع ولون.

1.  gray	2.  red	3.  yellow
---	--	---

6 Look and circle. انظر وضع دائرة.

1.  red blue	2.  black brown	3.  green white
---	--	--

Notes for parents

4. Ask your child to look and circle (✓) or (X) according to the given word.

- اطلب من طفلك أن ينظر ويضع دائرة حول علامة (✓) أو (X) طبقاً للكلمة المعطاة له.

5. Ask your child to trace the words and color the pictures.

- اطلب من طفلك أن يتتبع الكلمات ويلون الصور.

6. Ask your child to look at each color and circle the correct word.

- اطلب من طفلك أن ينظر إلى كل لون ويضع دائرة حول الكلمة الصحيحة.

Lesson
12

• Connect with Geography

Language

★ Identifying seasons of the year. التعرف على فصول السنة.



It's winter.
إنه فصل الشتاء.



It's summer.
إنه فصل الصيف.

★ Expressing likes التعبير عن ما تحبه.



I like winter.
أنا أحب فصل الشتاء.

I like summer.
أنا أحب فصل الصيف.



- Help your child to differentiate between winter and summer.
- Help your child to express what he/she likes.

- ساعد طفلك أن يفرق بين فصل الشتاء وفصل الصيف.
- ساعد طفلك أن يعبر عما يحبه / تحبه.

Activity

☆ Match and Color . صل ولون.

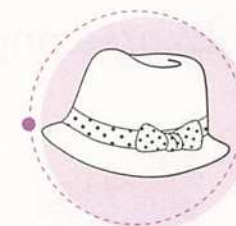
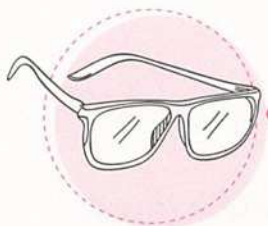

Notes for parents

• Help your child match the clothes with their suitable season and color them.

- ساعد طفلك أن يصل الملابس بالفضل المناسب لها ويلونها.

Activities on Lesson 12



Put a sticker according to your assessment

1 Listen and circle. استمع وضع دائرة.

1. summer



2. winter



3. sun



2 Listen and match. استمع وصل.

summer

winter

cloud



3 Listen and tick (✓). استمع وضع علامة (✓).

1.



summer

winter

2.



rain

sun

1. Ask your child to listen to the word and circle its correct picture.

- اطلب من طفلك أن يستمع إلى كل كلمة ويضع دائرة حول الصورة الصحيحة لها.

2. Ask your child to listen to the words and match them with the correct pictures.

- اطلب من طفلك أن يستمع إلى الكلمات ويصل الكلمات بالصور الصحيحة.

3. Ask your child to listen and tick (✓) the correct word.

- اطلب من طفلك أن يستمع ويضع علامة (✓) أمام الكلمة الصحيحة.

Activities on Lesson 12

4 Look and circle (✓) or (X). انظر وضع دائرة حول (✓) او (X).

1.



winter

✓ / X

2.



summer

✓ / X

3.



sun

✓ / X

5 Listen and circle. استمع وضع دائرة.

1.



It's winter .
summer

2.



I like winter .
summer

3.



It's moon .
sun

4.



It's a cloud .
It's

6 Trace. تتبع.

I like summer.

I like summer.

Notes for parents

4. Ask your child to look and circle (✓) or (X) according to the given word.

- اطلب من طفلك أن ينظر ويضع دائرة حول علامة (✓) أو (X) طبقاً للكلمة المعطاة له.

5. Ask your child to listen to the sentences and circle the correct answer according to the given pictures.

- اطلب من طفلك أن يستمع الي الجمل ويضع دائرة حول الإجابة الصحيحة طبقاً للصور المعطاة .

6. Ask your child to trace the given sentence.

- اطلب من طفلك أن يتتبع الجمل المعطاة .

Let's help !

هيا بنا نساعد !

Wash your hands before you eat !

اغسل يديك قبل أن تأكل !

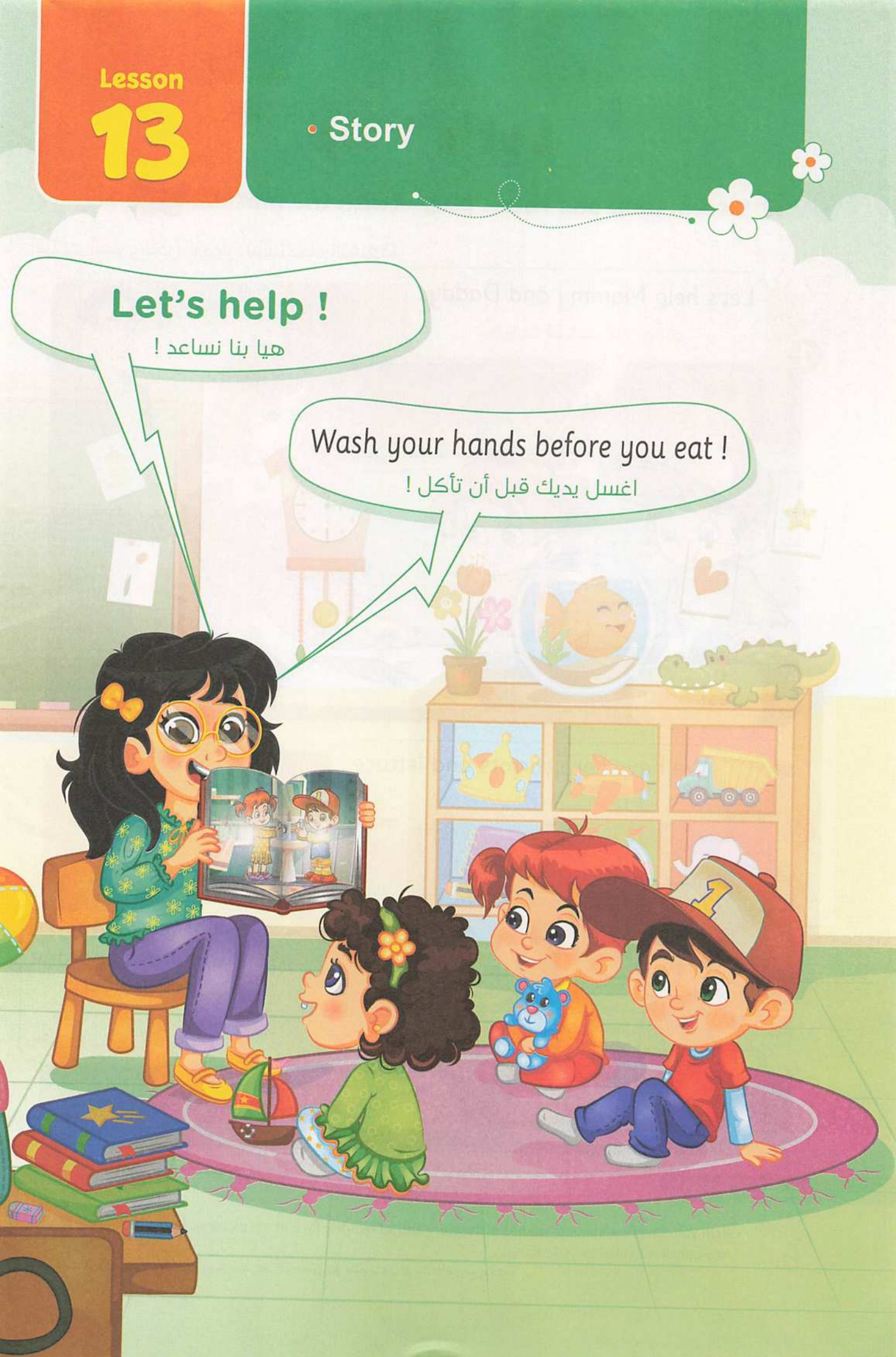

Let's help

★ Listen, look and role - play : (with the masks )

استمع، أنظر وتبادل الأدوار : (باستخدام الأقنعة)

Let's help Mommy and Daddy.

هيا بنا نساعد أمي وأبي.

1



Yes! نعم!

We have corn, carrots and lettuce.

نحن لدينا ذرة، جزر وخس.

2



We need two tomatoes and one cucumber.

نحن نحتاج ثمرتين
طماطم وخيارة واحدة.

OK! حسناً!

Notes for parents

- Help your child listen to the scenes of the story and let him/her look at the pictures, then ask him/her to role-play it with his/her colleagues.

Two red tomatoes.

ثمرتين طماطم حمراء.

3



I like tomatoes.

انا أحب الطماطم.

One green cucumber.

خيارة واحدة خضراء.

4

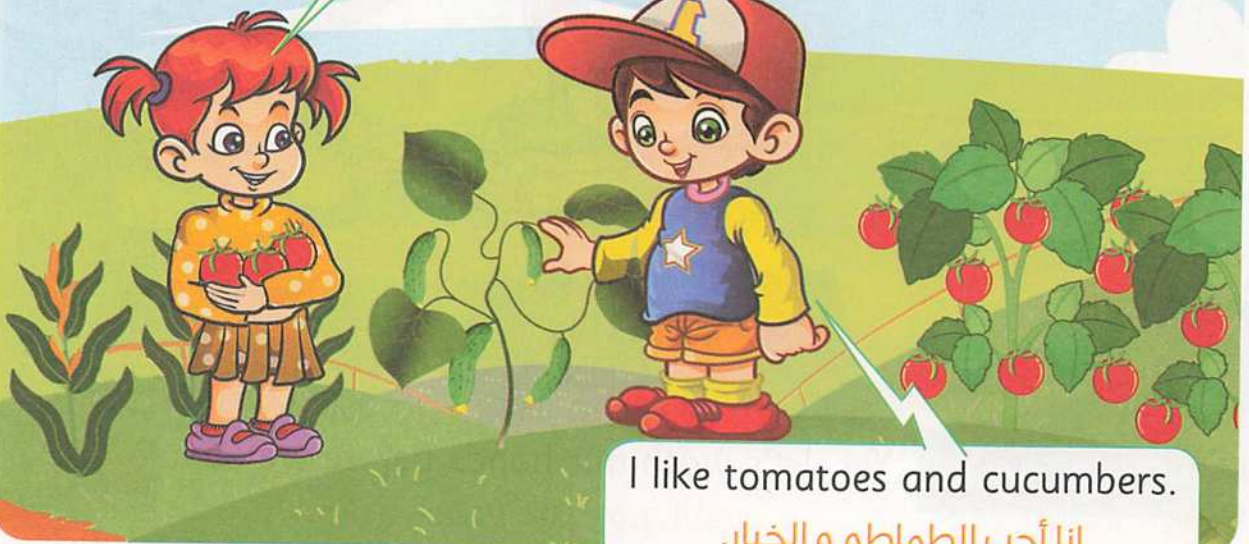

I like tomatoes and cucumbers.

انا أحب الطماطم و الخيار.

Adam, Dina, let's eat !

آدم، دينا، هيا بنا نأكل !

Mmm, salad !

ياه، إنها سلطة !

5



Adam, Dina, no !

آدم، دينا، لا !

Let's wash our hands.

هيا نغسل أيدينا.

6



Yes, let's wash our hands before we eat.

نعم، هيا نغسل أيدينا قبل الأكل.

★ Activity 1

★ Wash your hands, trace and Color. اغسل يديك، تتبع ولون.

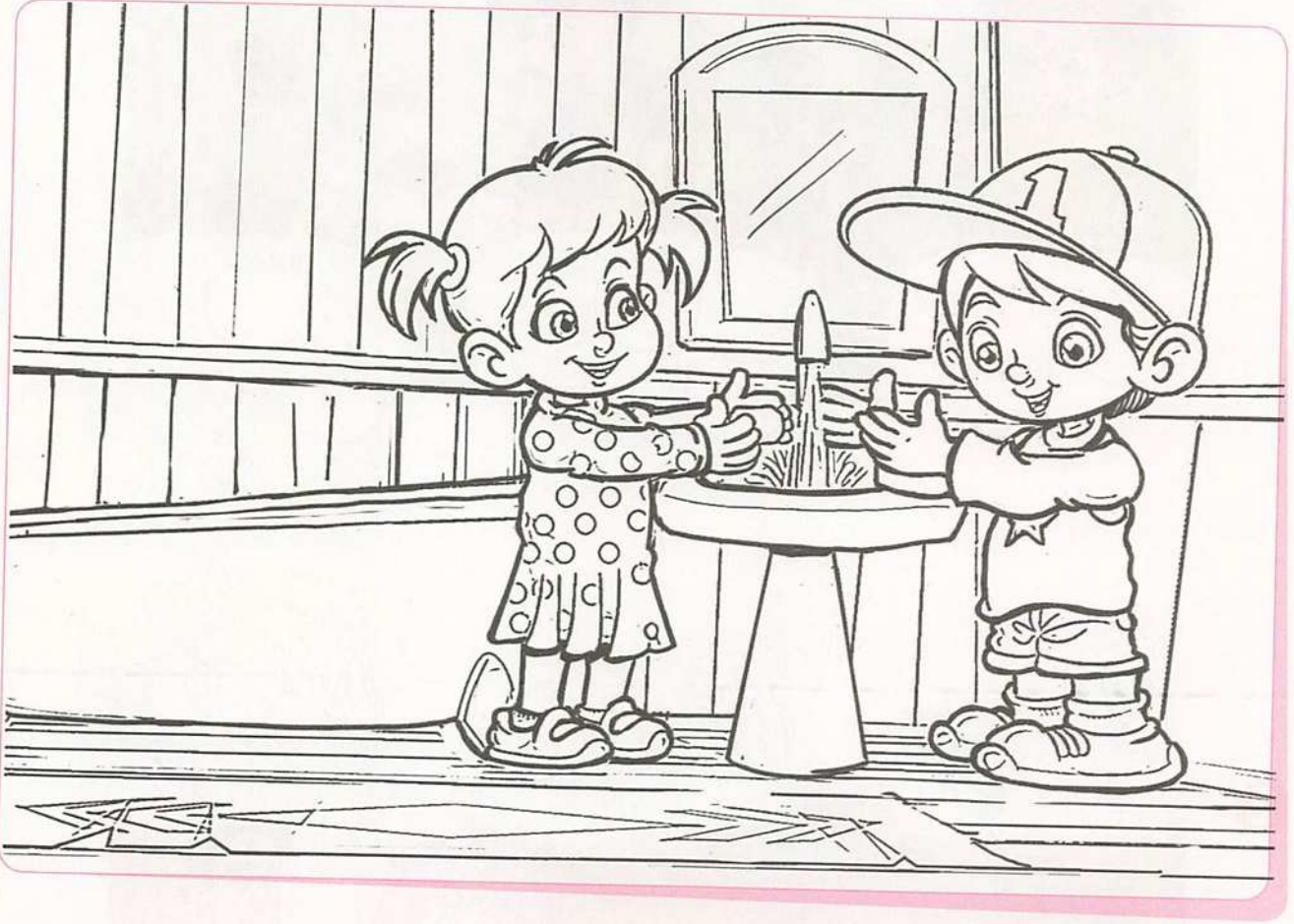

Let's wash our hands before we eat.

Let's wash our hands before we eat.

1. Ask your child to wash his / her hands, trace and color the picture.

- اطلب من طفلك أن يغسل يديه / يديها ويتتبع الجملة المكتوبة على شكل نقاط ويلون الصورة.

Activity 2

استمع، ضع علامة (✓) ولون. ★ Listen, tick (✓) and Color.

We need two tomatoes and one cucumber.

1

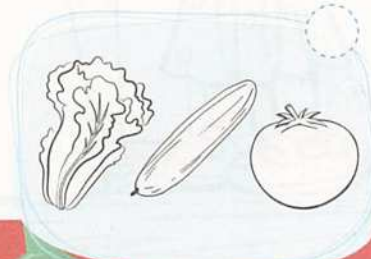
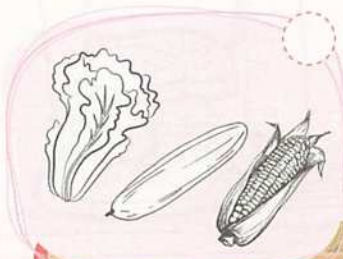
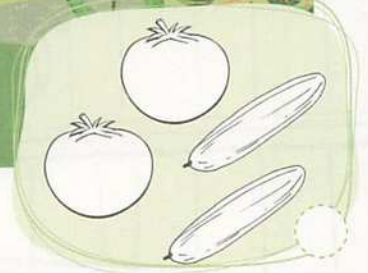
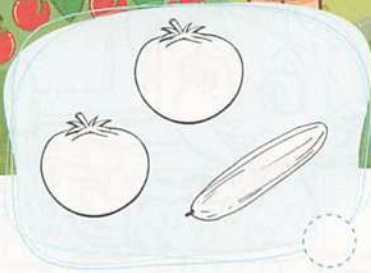
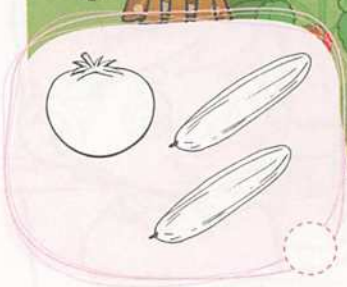

2



We have corn, carrots and lettuce.

Notes for parents

2. Help your child listen, tick (✓) in front of the correct picture according to the given sentences and color it.
- ساعد طفلك أن يستمع ويضع علامة (✓) للصورة الصحيحة طبقا للجمل المعطاة ويلونها.

Activities on Lesson 13



Put a sticker according to your assessment

1 Listen and circle. استمع وضع دائره.

1. corn



2. tomato



3. two cucumbers

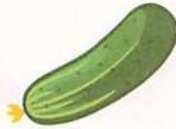

2 Listen and match. استمع وصل.

carrot

lettuce

green cucumber

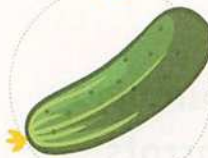
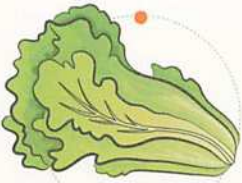

3 Listen and tick (✓). استمع وضع علامة (✓).

1.



cucumber

corn

2.



tomato

carrot

1. Ask your child to listen to the words and circle the correct picture.

2. Ask your child to listen to the words and match them with the correct pictures.

3. Ask your child to listen and tick (✓) the correct word.

Activities on Lesson 13

4 Look and circle (✓) or (X). انظر وضع دائرة حول علامة (✓) او (X).

1.



tomato

✓ / X

2.



lettuce

✓ / X

3.

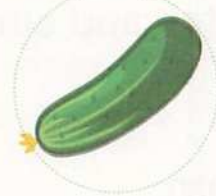

cucumber

✓ / X

5 Trace and circle. تتبع وضع دائرة.

1.



tomato

t

d

b

2.

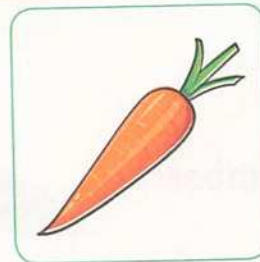

carrot

k

c

s

6 Listen and circle. استمع وضع دائرة.

1.



We need two tomatoes.

three

2.



We have cucumbers.

carrots

3.



We need one green carrot.

cucumber

4.



We have cucumber.

lettuce

Notes for parents

4. Ask your child to look and circle (✓) or (X) according to the given word.

- اطلب من طفلك أن ينظر ويضع دائرة حول علامة (✓) أو (X) طبقاً للكلمة المعطاة له.

5. Ask your child to trace the dotted letter and circle it.

- اطلب من طفلك أن يتتبع الحرف المكتوب على شكل نقاط ويضع دائرة حوله.

6. Ask your child to listen to the sentences and circle the correct answer according to the given pictures.

- اطلب من طفلك أن يستمع إلى الجمل ويضع دائرة حول الإجابة الصحيحة طبقاً للصور المعطاة.



★ Match, Color and write. صل، لَوْن و اكتب.

What can you see ?

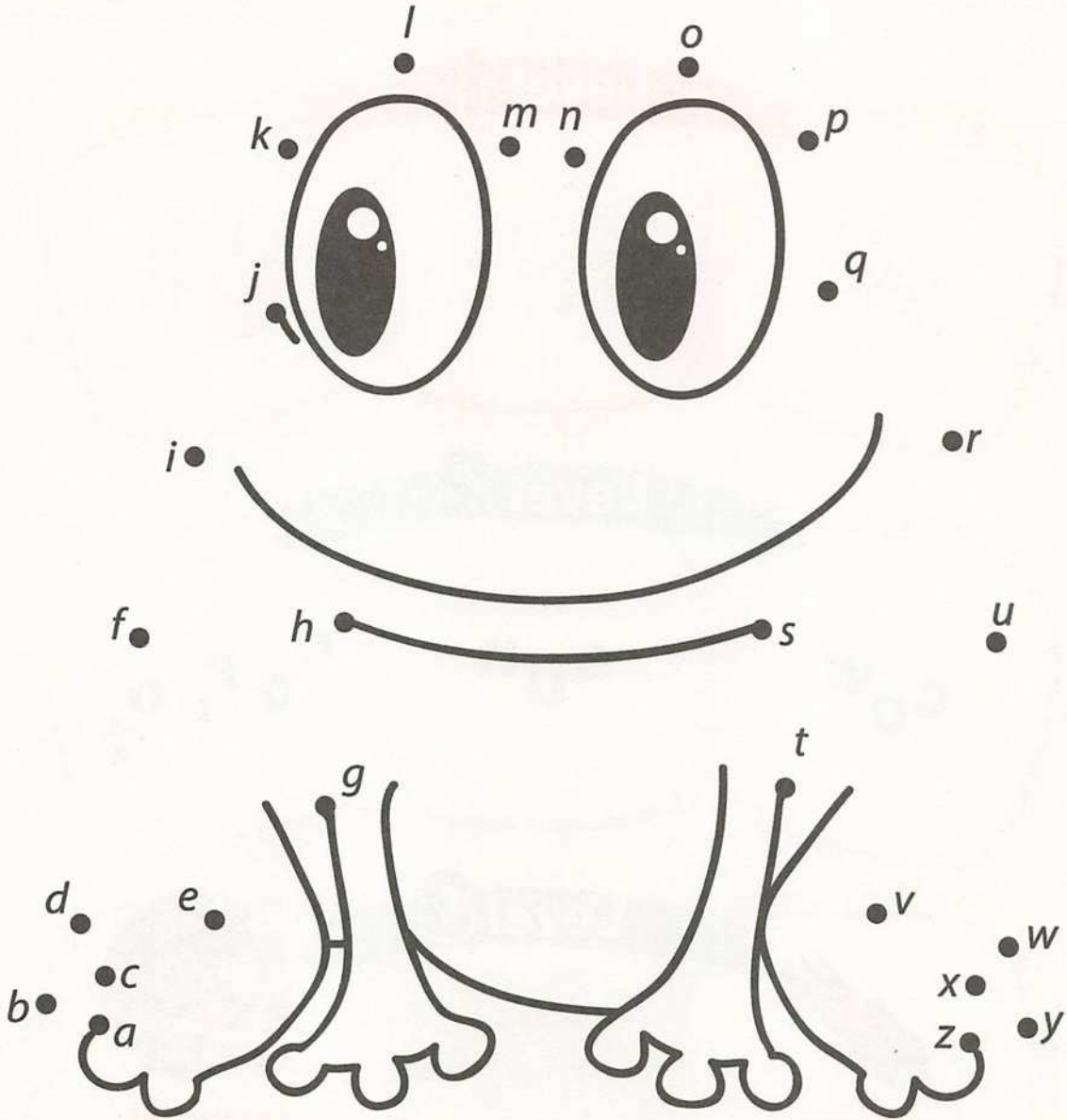

I can see a .

• Ask your child to connect the letters , color the picture and write its name.

- اطلب من طفلك أن يصل الحروف ويلوّن الصورة ويكتب اسمها.



ارشادات اللعبة

Mo Game

Start →

اطلب من طفلك ان يبحث عن الصور
في الكروت ويضع كل صورة على الظل
المناسب لها.

Level 1 ★

اطلب من طفلك ان يستمع الي الكلمات
ويبحث عنها في الكروت ويضع كل كلمة
على الكلمة المناسبة لها.

Level 2 ★

اطلب من طفلك ان يستمع الي الكلمات
ويبحث عن حروف كل كلمة في الكروت
ويضعها لتكون الكلمة.

Level 3 ★

Level 1



Level 2



Level 3



* استخدم كروت اللعبة من كراسة المعاصر التفاعلية.

* يحصل الطفل علي مبلغ Mo kids 50 مكافاة مع كل اجابة صحيحة.

* يمكن للطفل ان يلعب وحدة أو يشارك زميل أو أكثر في اللعبة. والفائز هو من يحصل علي نقود اكثر.

تنويه

Review on UNIT 4



carrot



tomato



lettuce

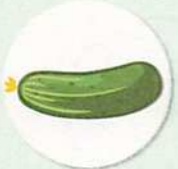

cucumber



corn



salad



rain



summer



duck



daddy

Dd



dog



Dina



sun

Ss



sad



salad



sister

Vocabulary

Phonics

Our world

Language

Issues

It's healthy.



It's unhealthy.



Let's wash our hands before we eat.



Let's wash our hands after we use the bathroom.

Activities on Unit 4



Put a sticker according to your assessment

1 Listen and circle. استمع وضع دائرة.

1. duck



2. summer



3. cucumber



2 Listen and match. استمع وصل.

white

hand

salad



3 Listen and tick (✓). استمع وضع علامة (✓).

1.



duck

horse

2.



carrots

cucumbers

Notes for parents

1. Ask your child to listen to the words and circle the correct picture.

- اطلب من طفلك أن يستمع إلى الكلمات ويضع دائرة حول الصورة الصحيحة.

2. Ask your child to listen to the words and match them with the correct pictures.

- اطلب من طفلك أن يستمع إلى الكلمات ويصل الكلمات بالصور الصحيحة.

3. Ask your child to listen and tick (✓) the correct word.

- اطلب من طفلك أن يستمع ويضع علامة (✓) أمام الكلمة الصحيحة.

4 Look and circle (✓) or (X). انظر وضع دائرة حول علامة (✓) او (X).

1.



food

✓ / X

2.



water

✓ / X

3.



black

✓ / X

5 Trace and Color. تتبع ولون.

1.



winter

2.

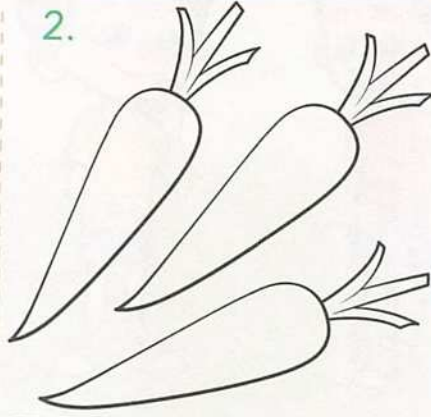

carrots

3.



summer

6 Look and circle. انظر وضع دائرة.

1.



black
brown

2.



winter
summer

3.



river
sea

4. Ask your child to look and circle (✓) or (X) according to the given word.

- اطلب من طفلك أن ينظر إلى الصور ويضع دائرة حول علامة (✓) أو (X) طبقاً للكلمة المعطاة له.

5. Ask your child to trace the words and color the pictures.

- اطلب من طفلك أن يتتبع الكلمات ويلون الصور.

6. Ask your child to look at each picture and circle the correct word.

- اطلب من طفلك أن ينظر إلى كل صورة ويضع دائرة حول الكلمة الصحيحة.

The Boys and the Frogs

الأولاد و الضفادع

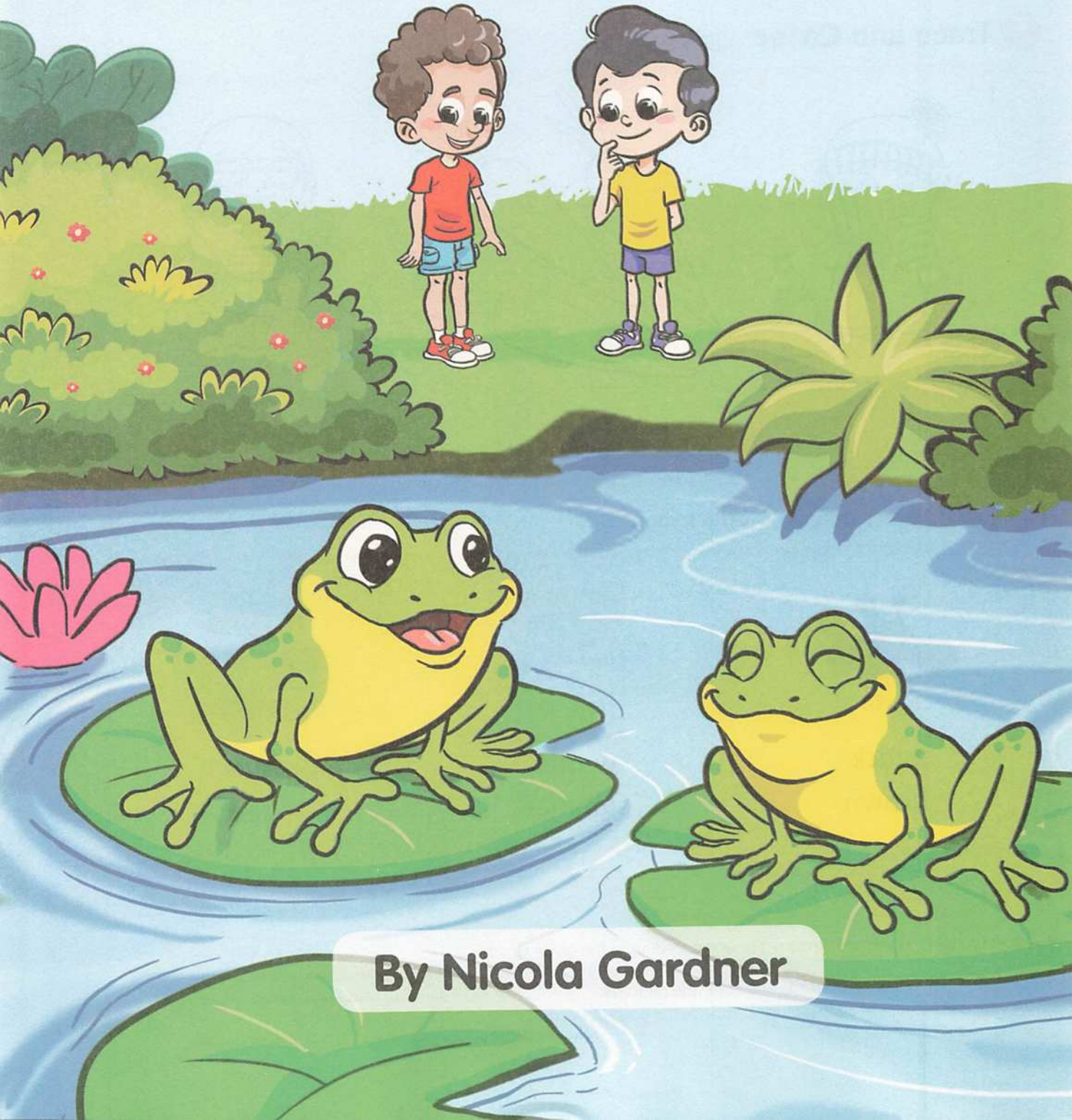

By Nicola Gardner

The topic



The main idea of the story is about الفكرة الرئيسية لهذه القصة عن

- How we can care for animals and nature.

كيف نستطيع الاهتمام بالحيوانات و الطبيعة.



The characters

الشخصيات



Seleem سليم



Mazen مازن

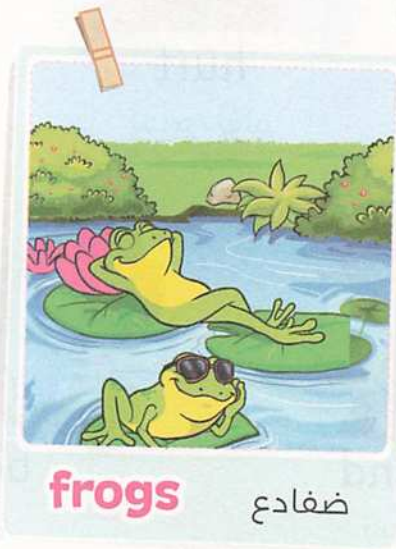

frogs ضفادع

- Help your child identify the main idea of the story.
- Help your child identify the characters of the story.

- ساعد طفلك في أن يتعرف على الفكرة الرئيسية للقصة.
- ساعد طفلك في التعرف على الشخصيات في القصة.

Picture Dictionary



play

يلعب



pond

بركة ماء

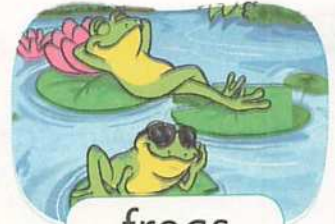

frogs

ضفادع



water

ماء



happy

لسعيد



flowers

زهور



sad

حزين



hurt

يجرح / يؤلم



game

لعبة



friend

صديق



boys

أولاد



Story Map

خريطة القصة

Who?

The main characters

الشخصيات الرئيسية



Seleem



Mazen

Who?

The supporting characters

الشخصيات المساعدة



frogs

Where? The setting

أين؟ المكان



بركة ماء pond

Beginning

بداية القصة



Seleem and Mazen
are playing.

Middle

منتصف القصة



They can see water
and flowers.

End

نهاية القصة



The boys and the
frogs are friends.

• Help your child to know the main characters and places in the story.

- ساعد طفلك أن يعرف الشخصيات الرئيسية في القصة والأماكن الموجودة في القصة.

• Help your child to know what happened in the beginning, the middle and at the end of the story.

- ساعد طفلك على معرفة ما حدث في بداية ومنتصف ونهاية القصة.

هذا سليم. هذا مازن. This is Selem. This is Mazen.



Let's play !

هيا بنا نلعب !



play

يلعبون

يلعب

★ Listen, read and trace.

استمع، اقرأ وتتبع.

Look! It's a pond!

انظر! إنها بركة ماء!

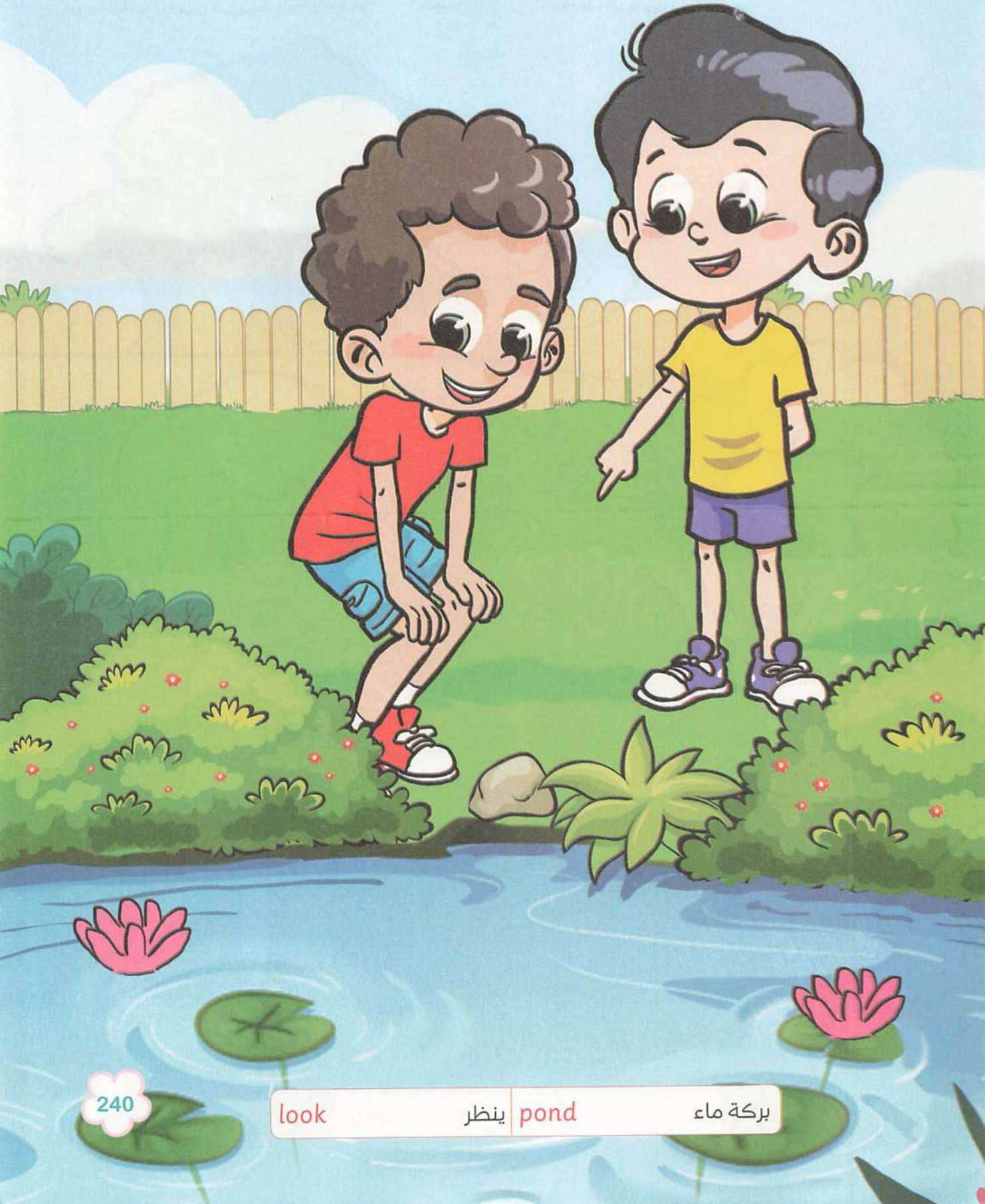

☆ Listen, read and trace.

استمع، اقرأ وتتبع.

I can see water. I can see flowers.

أنا أستطيع أن أرى ماء. أنا أستطيع أن أرى زهور.

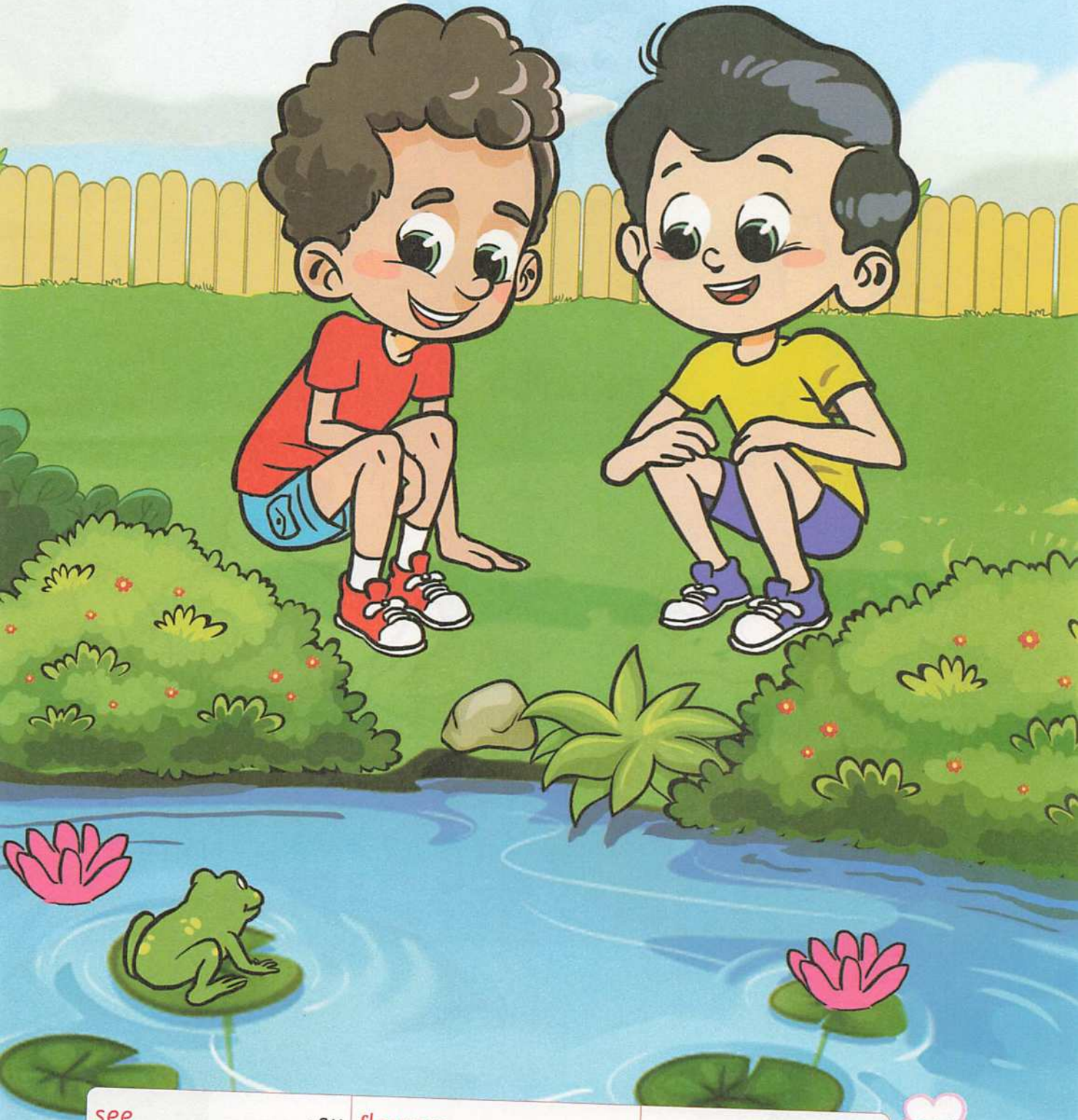

see

يرى flowers

زهور water

ماء

241

☆ Listen, trace and Color. استمع، تتبع ولون.

We are happy frogs.

نحن ضفادع سعيدة.



☆ Listen, trace and Color. استمع، تتبع ولون.

We like our pond. نحن نحب بركة الماء الخاصة بنا.



like

يحب

This is fun !

هذا ممتع !

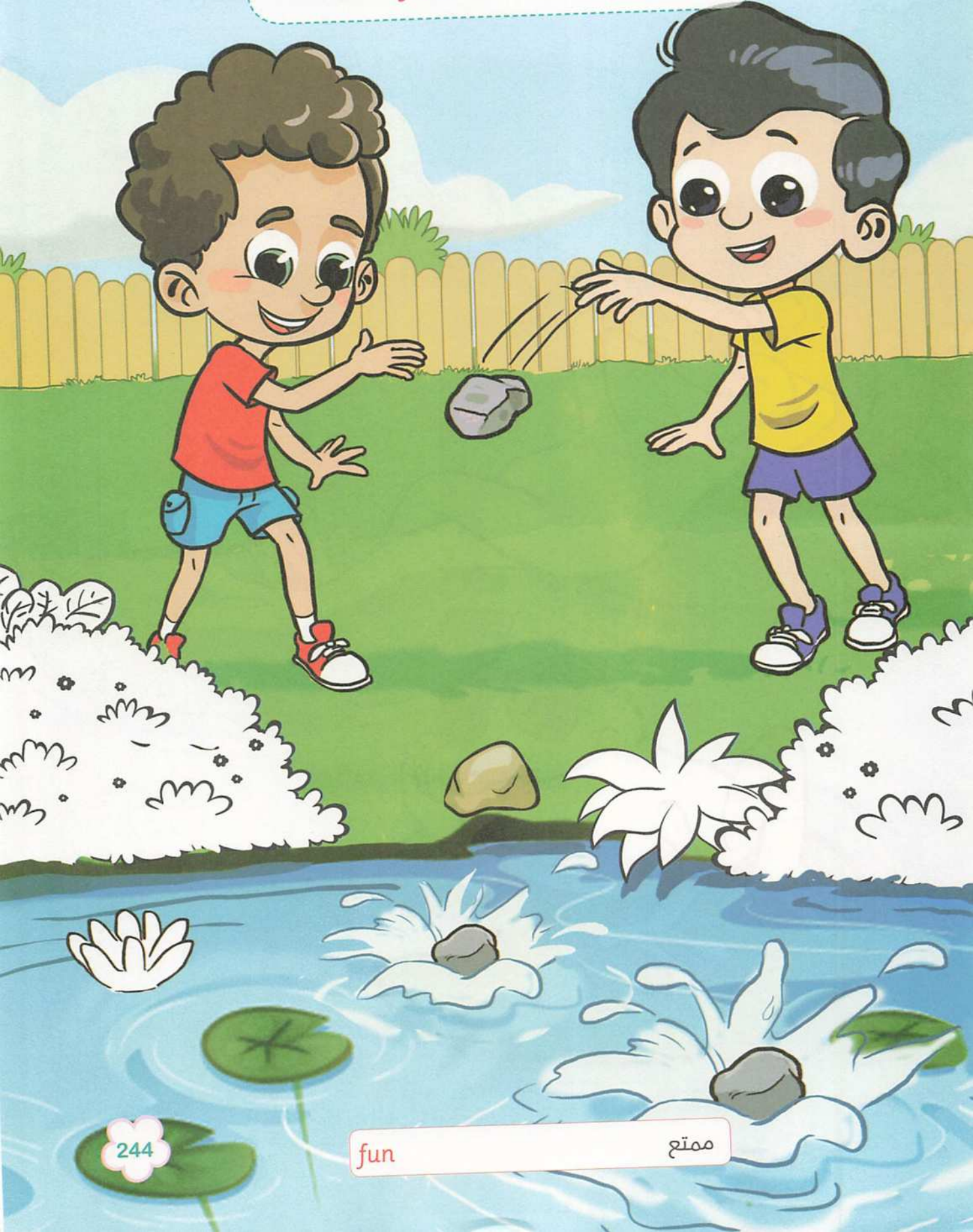

★ Listen, read and Color.

استمع، اقرأ ولون.

We are sad frogs. نحن ضفادع حزينة.

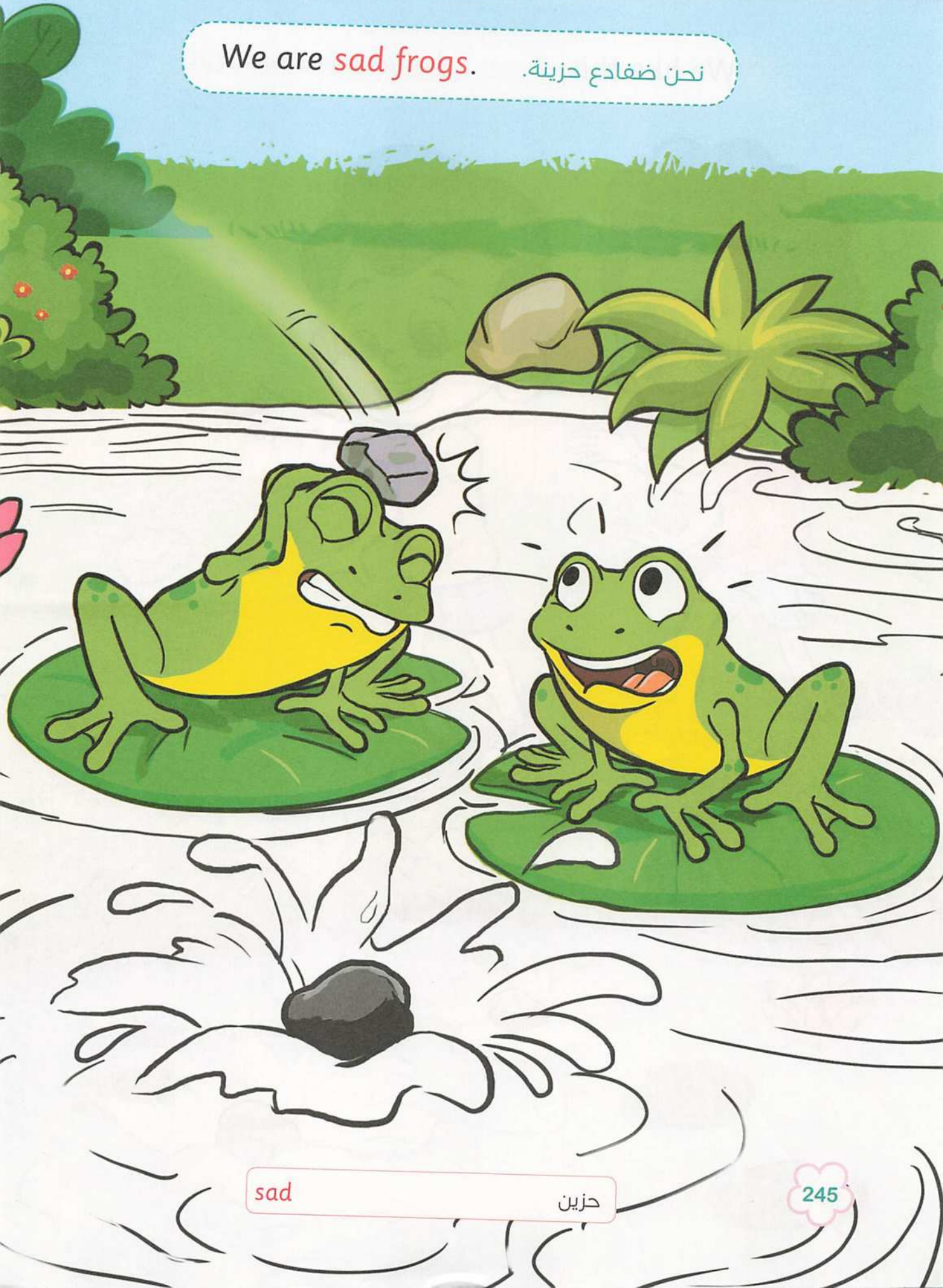

sad

حزين

245

★ Listen, read and trace.

استمع، اقرأ وتتبع.

We like this game ! نحن نحب هذه اللعبة !

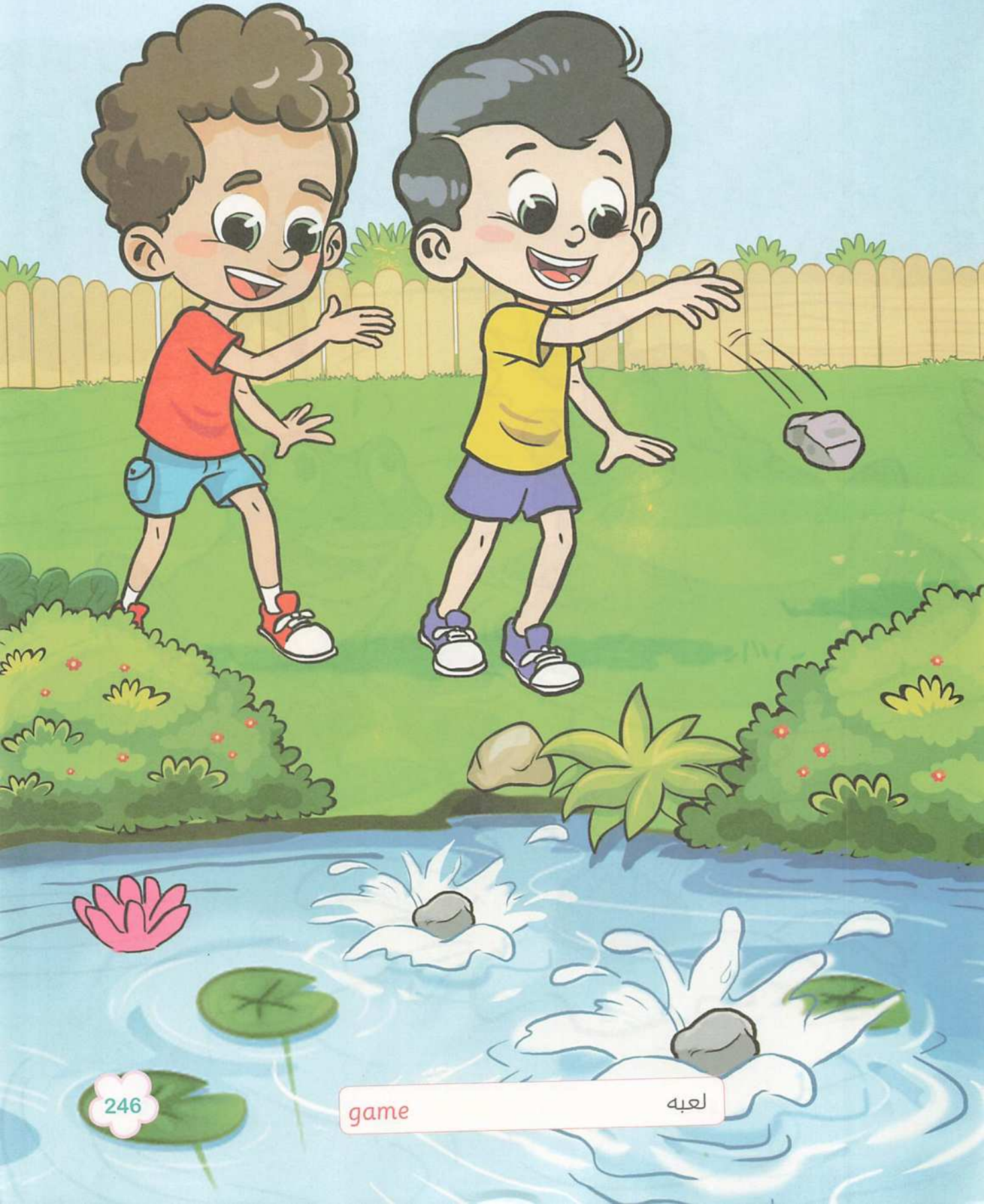

☆ Listen, read and trace.

استمع، اقرأ وتتبع.

Stop ! توقف !

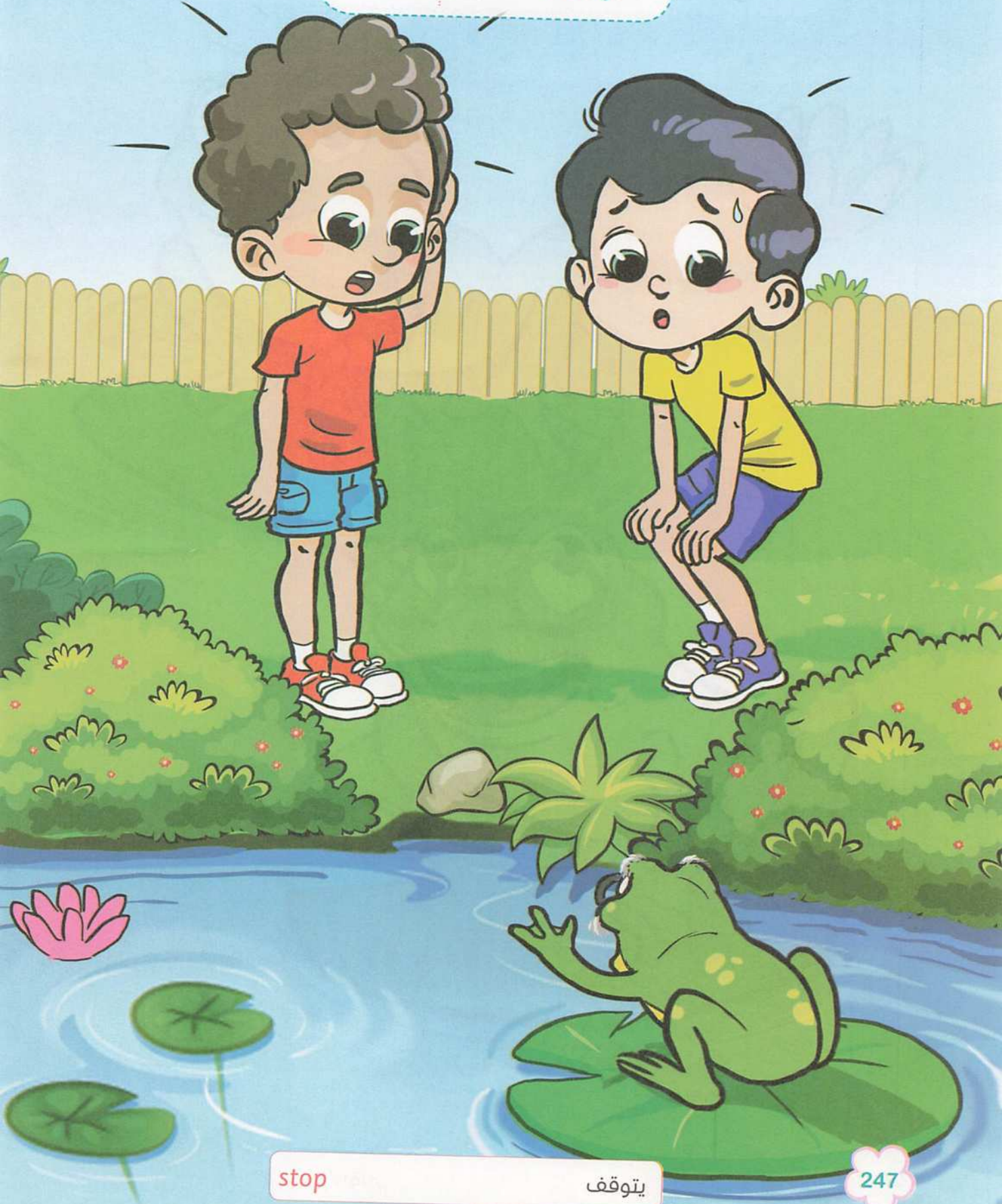

stop

يتوقف

My friend is hurt!

لقد جرح صديقي!



★ Listen, read and trace.

استمع، اقرأ وتتبع.

Sorry, frogs!

آسف، أيتها الضفادع!



Sorry!

آسف!

We are friends. نحن أصدقاء.

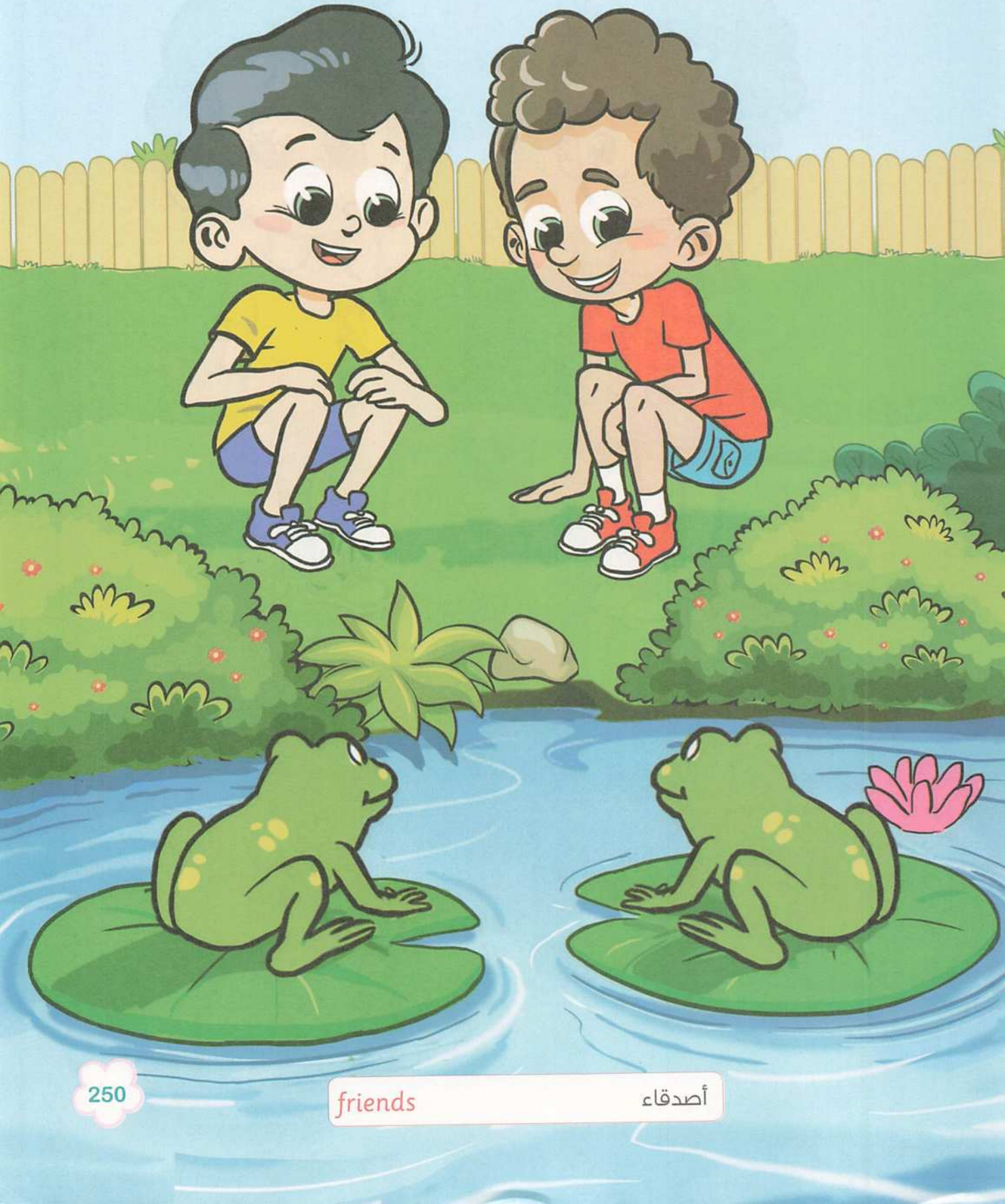

Activities on Story



Put
a sticker
according to your
assessment

1 Look, Color and trace. انظر ، لون وتتبع.

1

We are
happy frogs.

2

We like
our pond.

3

We are sad
frogs.

4

My friend is
hurt!

We are friends.

1. Help your child to look at the picture, color it and trace the words. - ساعد طفلك في النظر إلى الصورة وتلوينها وتتبع الكلمات.

2 Read and circle. اقرأ وضع دائرة.

1

The frogs like the
pond / park.

2

Seleem and Mazen
are
brothers / friends.



3

The frog is
angry / sad.

4

Seleem and
Mazen can see
frogs / flowers.

Notes for parents

2. Help your child to read the sentences and circle the correct answer according to the story.

– ساعد طفلك أن يقرأ الجمل ويضع دائرة حول الإجابة الصحيحة طبقاً للقصة.

3 Listen and match. استمع وصل.

1. Let's play !

2. We are happy frogs.

3. We are sad frogs.

4. I can see flowers.



4 Look, match and trace. انظر، صل وتتبع.

pond

boy

frog

flower



3. Ask your child to listen to each sentence and match it to its suitable picture.

- اطلب من طفلك أن يستمع إلى الجمل ويصلها بالصورة المناسبة لها.

4. Ask your child to look, match and trace the words.

- اطلب من طفلك أن ينظر إلى الصورة، يصل كل جملة بالصورة ويتتبع الكلمات.

Activities on Story

5 Listen and circle. استمع وضع دائرة.

1. This is Seleem.



2. It's a pond !



3. We are friends.



6 Read and put the pictures in the correct order.

أقرأ وضع الصور فى الترتيب الصحيح.

1. This is fun !

2. We are friends.

3. We are sad frogs.

4. We are happy frogs.



Notes for parents

5. Ask your child to listen and circle the correct picture according to the given sentence.

- اطلب من طفلك أن يستمع ويضع دائرة حول الصورة الصحيحة وفقاً للجملة المعطاه له.

6. Ask your child to read and put the pictures in the correct order according to the events of the story.

- اطلب من طفلك أن يقرأ ويضع الصور فى الترتيب الصحيح وفقاً لأحداث القصة.

7 Look and tick (✓). انظر وضع علامة (✓).

1.



sad
happy

2.



flowers
boys

3.



Seleem
frog

8 Look and draw 😊 or ☹️ . انظر وارسم 😊 او ☹️



9 Trace and Color. تتبع ولون.



We can care for animals and nature

7. Ask your child to look and tick (✓) for the correct word according to the given picture.

• اطلب من طفلك أن ينظر ويضع علامة (✓) للكلمة الصحيحة وفقاً للصورة المعطاه له.

8. Ask your child to look and draw 😊 for good behavior and ☹️ for bad behavior.

• اطلب من طفلك ان ينظر ويرسم 😊 للسلوك الجيد و ☹️ للسلوك السيئ.

9. Ask your child to trace the sentence and color the picture.

• اطلب من طفلك ان يتتبع الجملة ويلون الصورة.

Certificate

Congratulations to

Name:

Date:

for successfully finishing this book



يُصرف مجاناً مع الكتاب

- كراسة المعاصر التفاعلية
- أقنعة للتثمين
- استيكر ملصق
- لعبة Mo Kids



ل كودك الشخصي
تجود على ظهر الغلاف
زيد من المعلومات
ر صفحتي ٤، ٥



EL-MOASSER

Parents' Guide

NOW

at all bookstores...

EL-MOASSER IN CONNECT PLUS & DISCOVER

is an ideal supplement to Connect KG 1 Plus. It aims at guiding parents how to enhance their children's English language skills and knowledge through detailed and clear instructions. It has supporting activities which have been developed carefully to fulfill Connect KG 1 Plus objectives based on Content and Language Integrated Learning (CLIL).

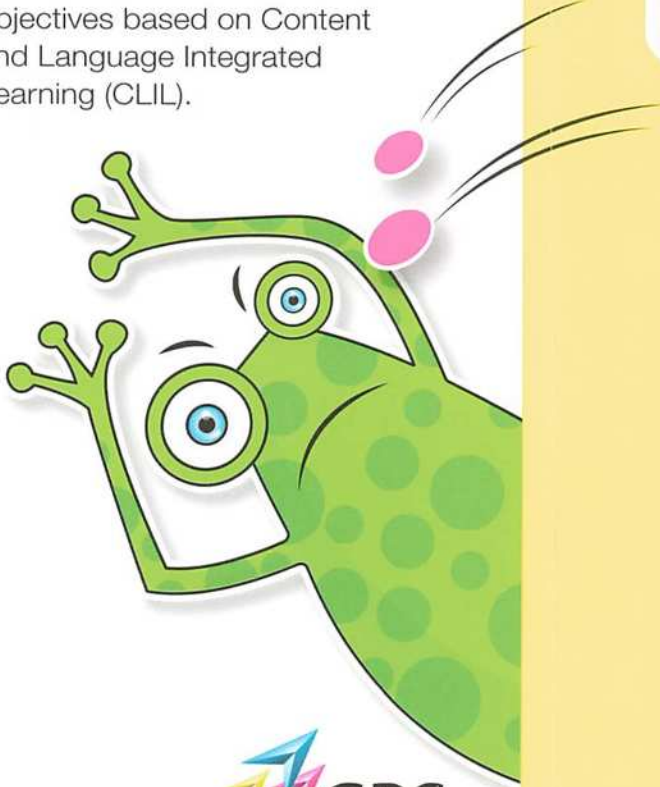

AL TALABA BOOKSTORE

For printing, publication & distribution

El Faggala - Cairo - Egypt

Tel.: 02/ 259 340 12 - 259 377 91

E-mail: info@elmoasserbooks.com

www.elmoasserbooks.com

15014

الآن بالمكتبات...

المعاصر في...

اللغة الإنجليزية

Connect Plus من kg1

إلى الصف الخامس الابتدائي

بتصريح وتحت إشراف

وزارة التربية والتعليم

CONNECT Plus



6 223007 311106

KG 1

FIRST TERM

f /ElMoasser.eg